

TRANSISTOR CROSS-REFERENCE GUIDE

mitsubishi

TEXAS INSTRUMENTS

MOTOROLA

SIEMENS

FAIRCHILD

NATIONAL

AEG-TELEFUNKEN

RCA

HITACHI

Westinghouse

GENERAL ELECTRIC

PHILIPS

TOSHIBA

INTRODUZIONE

Questo interessante volume raccoglie circa 5.000 diversi tipi di transistori, prodotti dalle principali case europee ed americane per il settore di consumo, e fornisce di essi l'indicazione di un eventuale equivalente prodotto da case orientali.

Le case di produzione europee o americane considerate sono le seguenti:

MOTOROLA

PHILIPS

G.E. (General Electric)

R.C.A. (Radio Corp. of America)

T.I. (Texas Instruments Inc.)

WESTINGHOUSE

AEG-TELEFUNKEN

L'elencazione dei tipi di transistori prodotti da queste case si svolge simmetricamente sulle due pagine affiancate del volume, e precisamente, sulla pagina pari (a sinistra) vengono forniti i principali parametri elettrici e meccanici del transistor, mentre, sulla pagina dispari (a destra) sono indicati gli eventuali tipi equivalenti.

La descrizione del singolo tipo di transistor avviene secondo un ordine di informazioni; indicazione del tipo, materiale e polarità; parametri massimi; caratteristiche elettriche; contenitore.

Tali informazioni sono ricavate dai "data-sheet" della Casa produttrice, e si è ritenuto che esse siano sufficienti per un corretto riconoscimento del transistor, relativamente almeno ai più diffusi campi di impiego.

Più in particolare, la descrizione avviene secondo i seguenti titoli, di cui forniamo breve spiegazione:

TYPE	USE	MATERIAL	POLARITY	MAXIMUM RATINGS				ELECTRICAL CHARACTERISTICS								OUTLINE TO.	NOTE				
				Pc 25°C (mW)	Tj (°C)	Vce (V)	Vcbo (V)	Ic (mA)	Icbo (μA)	hFE			hfe	hie (Ω)	hre (×10)			h _{oe} (μS)	ft * f _β * f _α (MHz)	NF (dB)	Cob (pF)
1	2	3	4	5				6			7			8			9	10	11	12	13

1) Indicazione del tipo (in ordine alfabetico e numerazione progressiva).

2) Indicazione dell'impiego tipico cui il dispositivo è destinato. Le sigle hanno il seguente significato:

A = amplificatore (impiego generale)

AH = amplificatore per alta frequenza

APH = amplificatore di potenza per alta frequenza

AP = amplificatore di potenza (impiego generale)

S = commutatore (impiego generale)
 SC = commutatore (sistemi logici)
 SH = commutatore ad alta velocità
 SHP = commutatore di potenza ad alta velocità
 SP = commutatore di potenza
 P = transistoro di potenza d'impiego generale
 LF = transistoro per impiego in bassa frequenza
 HF = transistoro per impiego in alta frequenza
 Delf = stadi di riga e quadro dei televisori
 AL = amplificatore sensibile alla luce
 AM = multiple silicon annular transistori (presente solo nei transistori Motorola)

SW = commutatore ad alta velocità media potenza

3) Indicazione del materiale costituente:

G = Germanio

S = Silicio

4) Indicazione della polarità:

P = PNP

N = NPN

Alcuni tipi indicano transistori complessi (es. Darlington); nel caso essi comprendano transistori di entrambe le polarità, ne viene data indicazione con la sigla: 'P/N'.

5) Parametri limite; essi comprendono l'indicazione di:

P_c = Potenza massima a 25°C

T_j = Temperatura massima della giunzione

V_{CB} = Massima tensione fra collettore e base

V_{CEO} = Massima tensione fra emettitore e collettore, con circuito di base aperto

I_c = Massima corrente nel circuito di collettore.

6) Indicazione della corrente dispersa nel circuito di collettore (I_{cBO}), relativa ad una data tensione fra collettore e base (V_{CB}) e con circuito di emettitore aperto.

7) Indicazione del guadagno in corrente continua nella configurazione ad emettitore comune (h_{FE} - valori limite min. e max.), relativo ad una data corrente di collettore (I_c)

8) Indicazione dei principali parametri h, e precisamente:

h_{fe} = guadagno in corrente alternata per piccoli segnali, nella configurazione ad emettitore comune

h_{ie} = impedenza d'ingresso per piccoli segnali, nella configurazione ad emettitore comune

h_{re} = rapporto di trasferimento di tensione inversa, su circuito aperto, nella configurazione ad emettitore comune

h_{oe} = ammettenza d'uscita, per piccoli segnali, nella configurazione ad emettitore comune

9) Indicazione della frequenza di taglio (f_T), definita come frequenza alla quale il guadagno in corrente per piccoli segnali, nella configurazione ad emettitore comune, approssima l'unità.

10) Indicazione della figura totale di rumore

11) Indicazione dei valori di capacità più importanti:

C_{ob} = capacità d'uscita nella configurazione a base comune

$C_{oxr/bb}$ = costante di tempo collettore-base

12) Indicazione del contenitore usato, secondo lo standard JEDEC (vedi il capitolo "Mechanical data")

Le Case produttrici orientali considerate per la ricerca dell'equivalente, sono le seguenti:

TOSHIBA
NEC
HITACHI
MITSUBISHI
MATSUSHITA
FUJITSU
SONY
SANIO

Riteniamo inutile ricordare i criteri normalmente impiegati nella compilazione delle tavole di equivalenza; ci interessa però sottolineare che, per i transistori, non è possibile garantire una equivalenza assoluta. Sebbene siano stati considerati i parametri principali in relazione all'uso tipico di ogni dispositivo, nel caso di applicazione particolari possono insorgere problemi non prevedibili. Ciò vale soprattutto nei circuiti per alte e altissime frequenze.

Per questi motivi suggeriamo un attento confronto dei parametri relativi alla configurazione d'impiego, per la verifica dell'indicazione di equivalenza.

TEXAS INSTRUMENTS

TYPE	USE	MATERIAL	POLARITY	MAXIMUM RATINGS					ELECTRICAL CHARACTERISTICS													OUTLINE TO.	NOTE
				Pc	Tj	Vas	Vceo	Ic	I _o		h _{FE}		h _{FE}	h _{FE}	h _{FE}	h _{FE}	h _{FE}	f _T	NF	Cob	Cox		
				25°C (mW)	(°C)	(V)	(V)	(mA)	(μA)	V _{CE} (V)	min.	max.	lc(mA)	(Ω)	(×10)	(μC)	(dB)	(pF)	(ps)				
2N117	A	S	N	150	175	45		25	2	30							**4	20	7		¼		
2N118	A	S	N	150	175	45		25	2	30							**5	20	7		¼		
2N118A	A	S	N	150	175	45		25	2	30							**8	20	7		¼		
2N119	A	S	N	150	175	45		25	2	30							**6	20	7		¼		
2N120	A	S	N	150	175	45		25	2	30							**7	20	7		¼		
2N243	A	S	N	750	150	60		60	1	30													
2N244	A	S	N	750	150	60		60	1	30													
2N332	A	S	N	150	175	45	45	25	2	30							**6	20	10		5		
2N333	A	S	N	150	175	45	45	25	2	30							**8	20	10		5		
2N334	A	S	N	150	175	45	45	25	2	30							**10	20	10		5		
2N335	A	S	N	150	175	45	45	25	2	30							**11	20	10		5		
2N336	A	S	N	150	175	45	45	25	2	30							**13	20	10		5		
2N337	SW	S	N	125		45	45	20	1	20							**20	2	5		5		
2N338	SW	S	N	125		45	45	20	1	20							**30	2	5		5		
2N339	A	S	N	10 ⁹	150	55	55	60	1	30												11	
2N340	A	S	N	10 ⁹	150	85	85	60	1	30												11	
2N341	A	S	N	10 ⁹	150	125	85	60	1	30												11	
2N342	A	S	N	10 ⁹	150	60	60	60	1	30												11	
2N343	A	S	N	10 ⁹	150	60	60	60	1	30												11	
2N389	AP	S	N	85W	200		60				12	60	1A									53	
A5T404	SW	S	P	625	150	25		150	0.1	12	30	400	12									¼	
A5T404A	SW	S	P	625	150	40		150	0.1	12	30	400	12									¼	
A8T404	SW	S	P	625	150	25		150	0.1	12	30	400	12									¼	
A8T404A	SW	S	P	625	150	40		150	0.1	12	30	400	12									¼	
2N424	AP	S	N	85W 100°C	200		80				12	60	1A									53	
2N456A	AP	G	P	150W	100	40	30	7A	500	20	30	90	5A									3	
2N456B	AP	G	P	150W	100	40	30	7A	500	20	30	90	5A									3	
2N457A	AP	G	P	150W	100	60	40	7A	500	30	30	90	5A									3	
2N457B	AP	G	P	150W	100	60	40	7A	500	30	30	90	5A									3	
2N458A	AP	G	P	150W	100	80	45	7A	500	40	30	90	5A									3	
2N458B	AP	G	P	150W	100	80	45	7A	500	40	30	90	5A									3	
2N497	AP	S	N	4W	200	60	60		10	30	12	36	200	30	250		70					5	
2N498	AP	S	N	4W	200	100	100		10	30	12	36	200	30	250		70					5	
2N511	AP	G	P	150W	100	40	30	25A	5mA	40	20	60	10A									¼	
2N511A	AP	G	P	150W	100	60	40	25A	5mA	60	20	60	10A									¼	
2N511B	AP	G	P	150W	100	80	45	25A	5mA	80	20	60	10A									¼	
2N512	AP	G	P	150W	100	40	30	25A	5mA	40	20	60	15A									¼	
2N512A	AP	G	P	150W	100	60	40	25A	5mA	60	20	60	15A									¼	
2N512B	AP	G	P	150W	100	80	45	25A	5mA	80	20	60	15A									¼	
2N656	AP	S	N	4W	200	60	60		10	30	30	90	200	60	350		90					5	
2N657	AP	S	N	4W	200	100	100		10	30	30	90	200	60	350		90					5	
2N696	AH	S	N	600	175	60			1	30	20	60	150						35			5	
2N697	AH	S	N	600	175	60			1	30	40	120	150						35			5	
2N698	AH	S	N	800		120			0.005	75	20	60	150		20	2.5	0.5					39	
2N699	AH	S	N	600		120			2	60	40	120	150		20	2.5	0.5					39	
2N717	SW	S	N	400	175	60			1	30	20	60	150						35			18	
2N718	SW	S	N	400	175	60			1	30	40	120	150						35			18	
2N718A	SW	S	N	500	200	75			0.01	60	20		0.1	35					25			18	
2N719	SW	S	N	400		120			2	60	20	60	150	25					20			18	
2N719A	SW	S	N	500		120		10 ⁹	0.01	75	20	60	150	25					15			18	
2N720	SW	S	N	400		120			2	60	40	120	150	45					20			18	
2N720A	SW	S	N	500		120			0.01	90	40	120	150	45					15			18	
2N721	SW	S	P	400	175	50			1	30	15		5	20					45			18	
2N722	SW	S	P	400	175	50			1	30	25		5	30					45			18	
2N730	SW	S	N	500	175	60		10 ⁹	1	30	20	60	150						35			18	

TYPE	TOSHIBA	NEC	HITACHI	MITSUBISHI	MATSUSHITA	FUJITU	SONY	SANYO	NOTE
2N117	2SC1000	2SC1428							
2N118	2SC1000	2SC1428							
2N118A	2SC1000	2SC1428							
2N119	2SC1000	2SC1428							
2N120	2SC1000	2SC1428							
2N243	2SC497								
2N244	2SC497								
2N332	2SC1000	2SC1428							
2N333	2SC1000	2SC1428							
2N334	2SC1000	2SC1428							
2N335	2SC1000	2SC1428							
2N336	2SC1000	2SC1428							
2N337	2SC1000	2SC1428							
2N338	2SC1000	2SC1428							
2N339									
2N340									
2N341									
2N342									
2N343									
2N389	2SC161	2SC242							
A5T404	2SA501				2SA546A				
A5T404A	2SA501				2SA546A				
A8T404	2SA501				2SA546A				
A8T404A	2SA501				2SA546A				
2N424	2SC161	2SC240	2SD125A						
2N456A							2SB520		
2N456B							2SB520		
2N457							2SB520		
2N457							2SB520		
2N458A							2SB520		
2N458B							2SB520		
2N497A			2SD120						
2N498B			2SD121						
2N511									
2N511A									
2N511B									
2N512									
2N512A									
2N512B									
2N656			2SD120						
2N657			2SD121						
2N696				2SC1211	2SC456	2SC1247A			
2N697				2SC1211	2SC456	2SC1247A			
2N698									
2N699									
2N717	2SC366Ⓒ			2SC1211	2SC456	2SC1247A			
2N718	2SC366Ⓒ			2SC1211	2SC456	2SC1247A			
2N718A				2SC1211	2SC456	2SC1247A			
2N719	2SC497	2SC959			2SC696A				
2N719A	2SC497	2SC959			2SC696A				
2N720	2SC497	2SC959			2SC696A				
2N720A	2SC497	2SC959			2SC696A				
2N721				2SA695	2SA546				
2N722				2SA695	2SA546				
2N730	2SC495			2SC1211	2SC456				

TYPE	USE	MATERIAL	POLARITY	MAXIMUM RATINGS						CHARACTERISTICS												OUTLINE TO.	NOTE				
				Pc 25°C (mW)	Tj (°C)	Vce (V)	Vceo (V)	Ic (mA)	Ibase (μA)	Vce(V) min.	Ic(max)	Ic(mA)	life	hie (Ω)	hfe (×10)	hbe (μA)	f _T at I _C **f _β (MHz)	NF (dB)	Cob (pF)	Corrb (ps)							
2N731	SW	S	N	500	175	60		1A	1	30	40	120	150									33		18			
2N849	SW	S	N	300	175	25	15	50	0.5	15	20	60	10												50		
2N850	SW	S	N	300	175	25	15	50	0.5	15	40	120	10												50		
2N851	SW	S	N	300	175	20	12	200			20	60	10												50		
2N852	SW	S	N	300	175	20	12	200			40	120	10												50		
2N870	SW	S	N	500		100			0.01	75	40	120	150	45											39		
2N871	SW	S	N	500		100			0.01	75	100	300	150	70											39		
2N910	SW	S	N	500		100			25n	75	35	0.1	80												18		
2N911	SW	S	N	500		100			25n	75	20	0.1	40												18		
2N912	SW	S	N	500		100			25n	75	10	0.1	20												18		
2N917	AH	S	N	200	200	30	15		1n	15															72		
2N918	AH	S	N	200		30	15	50	10n	15									60MHz						72		
D2T918	AH	S	N	200	200	30	15	50	10n	15	20	3													%		
2N929	A	S	N	300	175	45	45	30	10n	45	40	120	0.01	60						4		8			18		
2N930	A	S	N	300	175	45	45	30	10n	45	100	300	0.01	150					3		8				18		
2N956	HF	S	N	500	200	75			0.01	60	35	0.01	70							8		8			18		
2N997	SW	S	N	500	200	75	40	300	10n	60	1000	0.01										35			18	DARLINGTON	
2N998	SW	S	N	500	200	100	60	500	10n	90	800	0.01										30			72	DARLINGTON	
2N999	SW	S	N	500		60	60	500	10n	60	1000	0.01													72	DARLINGTON	
2N1021	AP	G	P	150W	100	100	50	7A	500	50	30	90	5												3		
2N1021A	AP	G	P	150W	100	100	50	7A	500	50	30	90	5												3		
2N1022	AP	G	P	150W	100	120	55	7A	500	60	30	90	5												3		
2N1022A	AP	G	P	150W	100	120	55	7A	500	60	30	90	5												3		
2N1038	AP	G	P	20W	100	40	40	3A	125	20	20	60	1A								100				5		
2N1039	AP	G	P	20W	100	60	60	3A	125	30	20	60	1A								100				5		
2N1040	AP	G	P	20W	100	80	80	3A	125	40	20	60	1A								100				5		
2N1041	AP	G	P	20W	100	100	100	3A	125	50	20	60	1A								100				5		
2N1042	AP	G	P	20W	100	40	40	3.5A	125	20	20	60	3A								100				5		
2N1043	AP	G	P	20W	100	60	60	3.5A	125	30	20	60	3A								100				5		
2N1044	AP	G	P	20W	100	80	80	3.5A	125	40	20	60	3A	6	0						100				%		
2N1045	AP	G	P	20W	100	100	100	3.5A	125	50	20	60	3A								100				5		
2N1046	AP	G	P	50W	100	100	50	12A	2mA	75	60	200	2A												3		
2N1047	AP	S	N	40W	200	80	80	500	15	30	12	36	500								50				57		
2N1047A	AP	S	N	40W	200	80	80	500	15	30	12	36	500								50				57		
2N1047B	AP	S	N	40W	200	80	80	750	15	30	12	36	500								50				57		
2N1048	AP	S	N	40W	200	120	120	500	15	30	12	36	500								50				57		
2N1048A	AP	S	N	40W	200	120	120	500	15	30	12	36	500								50				57		
2N1048B	AP	S	N	40W	200	120	120	750	15	30	12	36	500								50				57		
2N1049	AP	S	N	40W	200	80	80	500	15	30		90	500								50				57		
2N1049A	AP	S	N	40W	200	80	80	500	15	30	30	90	500								50				57		
2N1049B	AP	S	N	40W	200	80	80	750	15	30	30	90	500								50				57		
2N1050	AP	S	N	40W	200	120	120	500	15	30	30	90	500								50				57		
2N1050A	AP	S	N	40W	200	120	120	500	15	30	30	90	500								50				57		
2N1050B	AP	S	N	40W	200	120	120	750	15	30	30	90	500								50				57		
2N1131	APH	S	P	600	175	50	35	600	1	30	20	45	150	20							5			45	39		
2N1132	APH	S	P	600	175	50	35	600	1	30	30	90	150	30										45	39		
2N1149	A	S	N	150	175	45		25	2	30															7	%	
2N1150	A	S	N	150	175	45		25	2	30															7	%	
2N1151	A	S	N	150	175	45		25	2	30															7	%	
2N1152	A	S	N	150	175	45		25	2	30															7	%	
2N1153	A	S	N	150	175	45		25	2	30															7	%	
2N1154	A	S	N	750	150	50		60	5	50															%		
2N1155	A	S	N	750	150	80		50	6	80															%		
2N1156	A	S	N	750	150	120		40	8	120															%		
2N1420	AF	S	N	600	175	60		1A	1	30	100	300	150												5		

TYPE	TOSHIBA	NEC	HITACHI	mitsubishi	MATSUSHITA	FUJITU	SONY	SANYO	NOTE
2N731	2SC495		2SC1212		2SC456				
2N849			2SC282				2SC1128		
2N850			2SC282				2SC1128		
2N851	2SC735		2SC321H					2SC423	
2N852	2SC735		2SC321H					2SC423	
2N870	2SC497	2SC960			2SC696A				
2N871	2SC497	2SC960			2SC696A				
2N910	2SC497	2SC960			2SC696A				
2N911	2SC497	2SC960			2SC696A				
2N912	2SC497	2SC960			2SC696A				
2N917	2SC373	2SC923	2SC458	2SC712		2SC724		2SC536	
2N918	2SC373	2SC923	2SC458	2SC712		2SC724		2SC536	
D2T918									
2N929	2SC1000G	2SC899	2SC1345						
2N930	2SC1000G	2SC899	2SC1345						
2N956				2SC1211		2SC1247A			
2N997	2SC982								
2N998	2SC982								
2N999	2SC982								
2NI021							2SB520		
2NI021A							2SB520		
2NI022							2SB520		
2NI022A							2SB520		
2NI038	2SA490	2SA616							
2NI039	2SA490	2SA616							
2NI040	2SA489	2SA616							
2NI041	2SA489								
2NI042	2SA490	2SA616							
2NI043	2SA490	2SA616							
2NI044	2SA489	2SA616							
2NI045	2SA489								
2NI046		2SA650							
2NI047		2SC1185					2SC808		
2NI047A		2SC1185					2SC808		
2NI047B		2SC1185					2SC808		
2NI048		2SC1185					2SC808		
2NI048A		2SC1185					2SC808		
2NI048B		2SC1185					2SC808		
2NI049		2SC1185					2SC808		
2NI049A		2SC1185					2SC808		
2NI049B		2SC1185					2SC808		
2NI050		2SC1185					2SC808		
2NI050A		2SC1185					2SC808		
2NI050B		2SC1185					2SC808		
2NI131	2SA505	2SA606	2SA537		2SA546				
2NI132	2SA505	2SA606	2SA537		2SA546				
2NI149	2SC372						2SC632		
2NI150	2SC372						2SC632		
2NI151	2SC372						2SC632		
2NI152	2SC372						2SC632		
2NI153	2SC372						2SC632		
2NI154	2SC594						2SC470		
2NI155	2SC594						2SC470		
2NI156	2SC594						2SC470		
2NI420	2SC495		2SC1212		2SC456				

TYPE	USE	MATERIAL	POLARITY	MAXIMUM RATINGS				ELECTRICAL CHARACTERISTICS											OUTLINE TO.	NOTE				
				Pc 25°C (mW)	Tj (°C)	Vas (V)	Vcvo (V)	Ic (mA)	I _{oss}		hFE			hfe	hie (Ω)	hre ⁺ (×10 ³)	hoe (μΩ)	f _T *I _{oe} **f _{ab} (MHz)			NF (dB)	Cob (pF)	Coxbb (ps)	
									(μA)	Vor(V)	min	max	Ic(mA)											
2N1507	HF	S	N	600	175	60		1A	1	30	100	300	150										5	
2N1529	AP	G	P	106W	100	40	30	5A	20mA	40	20	40	3A				0.2						3	
2N1530	AP	G	P	106W	100	60	45	5A	20mA	60	20	40	3A				0.2						3	
2N1531	AP	G	P	106W	100	80	60	5A	20mA	80	20	40	3A				0.2						3	
2N1532	AP	G	P	106W	100	100	75	5A	20mA	100	20	40	3A				0.2						3	
2N1533	AP	G	P	106W	100	120	90	5A	20mA	120	20	40	3A				0.2						3	
2N1534	AP	G	P	106W	100	40	30	5A	20mA	40	35	70	3A				0.2						3	
2N1535	AP	G	P	106W	100	60	45	5A	20mA	60	35	70	3A				0.2						3	
2N1536	AP	G	P	106W	100	80	60	5A	20mA	80	35	70	3A				0.2						3	
2N1537	AP	G	P	106W	100	100	75	5A	20mA	100	35	70	3A				0.2						3	
2N1538	AP	G	P	106W	100	120	95	5A	20mA	120	35	70	3A				0.2						3	
2N1539	AP	G	P	106W	100	40	30	5A	20mA	40	50	100	3A				0.2						3	
2N1540	AP	G	P	106W	100	60	45	5A	20mA	60	50	100	3A				0.2						3	
2N1541	AP	G	P	106W	100	80	60	5A	20mA	80	50	100	3A				0.2						3	
2N1542	AP	G	P	106W	100	100	75	5A	20mA	100	50	100	3A				0.2						3	
2N1543	AP	G	P	106W	100	120	95	5A	20mA	120	50	100	3A				0.2						3	
2N1544	AP	G	P	106W	100	40	30	5A	20mA	40	75	150	3A				0.2						3	
2N1545	AP	G	P	106W	100	60	45	5A	20mA	60	75	150	3A				0.2						3	
2N1546	AP	G	P	106W	100	80	30	5A	20mA	80	75	150	3A				0.2						3	
2N1547	AP	G	P	106W	100	100	75	5A	20mA	100	75	150	3A				0.2						3	
2N1548	AP	G	P	106W	100	120	95	5A	20mA	120	75	150	3A				0.2						3	
2N1566	AP	S	N	600		80	60	50	1	40	60	200	5									10	39	
2N1613	SW	S	N	800	200	75			0.01	60	20	0.1	35									35	5	
2N1711	A	S	N	800	200	75		1A	0.01	60	35	0.1	70									25	5	
2N1714	AP	S	N	800	175	90	60	750	1	3	20	60	200								50	50	5	
2N1715	AP	S	N	800	175	150	100	750	1	3	20	60	200								50	50	5	
2N1716	AP	S	N	800	175	90	60	750	1	3	40	120	200								50	50	5	
2N1717	AP	S	N	800	175	150	100	750	1	3	40	120	200								50	50	5	
2N1718	AP	S	N	2W	175	90	60	750	1	3	20	60	200								50	50		
2N1719	AP	S	N	2W	175	150	100	750	1	3	20	60	200								50	50		
2N1720	AP	S	N	2W	175	90	60	750	1	3	40	120	200								50	50		
2N1721	AP	S	N	2W	175	150	100	750	1	3	40	120	200								50	50		
2N1722	AP	S	N	50W	175	80		5A			20	90	2A											53
2N1722A	AP	S	N	50W	175	180	120	5A	0.1	3	30	90	2A											53
2N1723	AP	S	N	50W	175	120	80	5A	0.1	3	50	150	2A											61
2N1724	AP	S	N	50W	175	80		5A			20	90	2A											61
2N1724A	AP	S	N	50W	175	180	120	5A	0.1	3	30	90	2A											61
2N1725	AP	S	N	50W	175	120	80	5A	0.1	3	50	150	2A											61
2N1889	SW	S	N	800		100			0.01	75	40	120	150	45						**120		15	39	
2N1890	SW	S	N	800		100			0.01	75	100	300	150	70						**120		15	39	
2N1893	SW	S	N	800		120		500	0.01	90	40	120	150	45						**120		15	39	
2N1907	AP	G	P	60W	100	100	40	20A	2mA	75	30	170	10A											3
2N1908	AP	G	P	60W	100	130	50	20A	2mA	100	30	170	10A											3
2N1936	AP	S	N	150W	175	125	60	20A			10	50	10A											63
2N1937	AP	S	N	150W	175	125	80	20A			10	50	10A											63
2N1973	A	S	N	800		100			25n	75	35	0.1	80						**120		15	39		
2N1974	A	S	N	800		100			25n	75	20	0.1	40						**120		15	39		
2N1975	A	S	N	800		100			25n	75	10	0.1	20						**120		15	39		
2N2060	A	S	N	500	200	100		500	2n	80	40	120	1											
2N2102	AP	S	N	1W		120	65	1A	2n	60	40	120	150											39
2N2102A	AP	S	N	1W		120	65	1A	2n	60	40	120	150											39
2N2150	AP	S	N	30W	175	125	80	6A			20	60	500											111
2N2151	AP	S	N	30W	175	125	80	6A			40	120	500								160			111
2N2192	SW	S	N	800		60	40	1A	10n	30	100	300	150								20			39
2N2192A	SW	S	N	800		60	40	1A	10n	30	100	300	150								20			39

TYPE	TOSHIBA	NEC	HITACHI	mitsubishi	MATSUSHITA	FUJITSU	SONY	SANYO	NOTE
2NI507	2SC486			2SC816	2SC775				
2NI529	2SA680						2SB519		
2NI530	2SA680						2SB519		
2NI531	2SA680						2SB519		
2NI532	2SA679						2SB519		
2NI533	2SA679						2SB520		
2NI534	2SA680						2SB519		
2NI535	2SA680						2SB519		
2NI536	2SA680						2SB519		
2NI537	2SA679						2SB519		
2NI538	2SA679						2SB520		
2NI539	2SA680						2SB519		
2NI540	2SA680						2SB519		
2NI541	2SA680						2SB519		
2NI542	2SA679						2SB519		
2NI543	2SA679						2SB520		
2NI544	2SA680						2SB519		
2NI545	2SA680						2SB519		
2NI546	2SA680						2SB519		
2NI547	2SA679						2SB519		
2NI548	2SA679						2SB520		
2NI566	2SC199				2SC456	2SC1247A			
2NI613	2SC485	2SC781			2SC696				
2NI711	2SC485	2SC781			2SC696				
2NI714	2SC512	2SC959			2SC696				
2NI715	2SC510	2SC959			2SC696A				
2NI716	2SC512	2SC959			2SC696				
2NI717	2SC510	2SC959			2SC696A				
2NI718	2SC522				2SC697A		2SC756		
2NI719	2SC522				2SC697A		2SC756		
2NI720	2SC522				2SC697A		2SC756		
2NI721	2SC522				2SC697A		2SC756		
2NI722	2SC520A	2SC940	2SC1030						
2NI722A	2SC518A	2SC940	2SC897						
2NI723	2SC519A	2SC940	2SC897						
2NI724	2SC520A	2SC940	2SC1030						
2NI724A	2SC518A	2SC940	2SC897						
2NI725	2SC519A	2SC940	2SC897						
2NI889	2SC1382		2SC1212A				2SC1124		
2NI890	2SC1382		2SC1212A				2SC1124		
2NI893	2SC1382		2SC1212A				2SC1124		
2NI907				2SB480		2SB354			
2NI908									
2NI936	2SD113					2SD250			
2NI937	2SD113					2SD250			
2NI973	2SC497	2SC959			2SC696				
2NI974	2SC497	2SC959			2SC696				
2NI975	2SC497	2SC959			2SC696				
2N2060									
2N2102	2SC510	2SC960			2SC696A		2SC756	2SC614	
2N2102A	2SC510	2SC960			2SC696A		2SC756	2SC614	
2N2150	2SC519A	2SC939	2SC898		2SC901				
2N2151	2SC519A	2SC939	2SC898		2SC901				
2N2192	2SC485	2SC960						2SC614	
2N2192A	2SC485	2SC960						2SC614	

TYPE	USE	MATERIAL	POLARITY	MAXIMUM RATINGS				ELECTRICAL CHARACTERISTICS														OUTLINE TO.	NOTE
				Pc 25°C (mW)	Tj (°C)	Vas (V)	Vcto (V)	Ic (mA)	I _{oss}		h _{FE}		hfe	h _{ie} (Ω)	h _{re} (×10)	h _{oe} (μS)	f _T = f _{20dB} = f _{10dB} (MHz)	NF (dB)	Cob (pF)	Cox _{tot} (pF)			
									I _{oss} (μA)	V _{ce} (V)	min	max									min		
A5T2192	SW	S	N	625	150	60	40	1A	10n	30	100	300	150						20	1/17			
2N2193	SW	S	N	800		80	50	1A	10n	60	40	120	150						20	39			
2N2193A	SW	S	N	800		80	50	1A	10n	60	40	120	150						20	39			
A5T2193	SW	S	N	625	150	80	50	1A	10n	60	40	120	150						20	1/17			
2N2194	SW	S	N	800		60	40	1A	10n	30	20	60	150						20	39			
2N2194A	SW	S	N	800		60	40	1A	10n	30	20	60	150						20	39			
2N2217	SW	S	N	800	175	60	30	800	10n	50	20	60	150			250			8	5			
2N2218	SW	S	N	800	175	60	30	800	10n	50	40	120	150			250			8	5			
2N2218A	SW	S	N	800	175	75	40	800	10n	60	40	120	150			250			8	5			
D2T2218	SW	S	N	400	175	60	30	800	10n	50	40	120	150			250			8	1/17			
D2T2218A	SW	S	N	400	175	75	40	800	10n	60	40	120	150			250			8	1/17			
2N2219	SW	S	N	800	175	60	30	800	10n	50	100	300	150			250			8	5			
2N2219A	SW	S	N	800	175	75	40	800	10n	60	100	300	150			300			8	5			
D2T2219	SW	S	N	400	175	60	30	800	10n	50	100	300	150			250			8	1/17			
D2T2219A	SW	S	N	400	175	75	40	800	10n	60	100	300	150			300			8	1/17			
2N2220	SW	S	N	500	175	60	30	800	10n	50	20	60	150			250			8	18			
2N2221	SW	S	N	500	175	60	30	800	10n	50	40	120	150			250			8	18			
2N2221A	SW	S	N	500	175	75	40	800	10n	60	40	120	150			250			8	18			
2N2222	SW	S	N	500	175	60	30	800	10n	50	100	300	150			250			8	18			
2N2222A	SW	S	N	500	175	75	40	800	10n	60	100	300	150			300			8	18			
O2T2222	SW	S	N	500	150	60	30	800	10n	50	100	300	150			250			8	116			
A5T2222	SW	S	N	625	150	60	30	800	10n	50	100	300	150			250			8	1/17			
2N2223	SW	S	N	500	200	100		500	10n	80	25	100	0.1					15	1/168				
2N2223A	SW	S	N	500	200	100		500	10n	80	25	100	0.1					15	1/168				
2N2243	SW	S	N	800	200	120	80	1A	10n	60	40	120	150					15	39				
2N2243A	SW	S	N	800	200	120	80	1A	10n	60	40	120	150			50		15	39				
A5T2243	SW	S	N	625	150	120	80	1A	10n	60	40	120	150			50		15	1/17				
2N2270	AP	S	N	1W		60	45	1A	50n	60	50	200	150							39			
2N2303	A	S	P	600		50	500	1	30	75	200	150	75					45	5				
2N2387	A	S	N	300	175	45	45	30	10n	45	40	120	0.01	60			4	8	50				
2N2388	A	S	N	300	175	45	45	30	10n	45	100	300	0.01	150			3	8	50				
2N2389	SW	S	N	450	200	75		500	10n	60	40	120	150	35			12	25	50				
2N2390	SW	S	N	450	200	75		500	10n	60	100	300	150	70			8	25	50				
2N2393	SW	S	P	450	175	50	35	300	1	30	20	45	150	20				45	50				
2N2394	SW	S	P	450	175	50	35	300	1	30	30	90	150	30				45	50				
2N2395	SW	S	N	450	200	60	40	300	10n	30	20	60	150							50			
2N2396	SW	S	N	450	200	60	40	300	10n	30	40	120	150							50			
2N2432	SC	S	N	300		30	30	100	10n	25	30		0.01							18			
2N2432A	SC	S	N	300		45	45	100	10n	40	30		0.01							18			
2N2453	A	S	N	200	200	60	30	50	5n	50	150	600	1	150	5K	6	30		8	1/168			
2N2483	A	S	N	360		60	60	50	10n	45	40	120	0.01	80	13K	8	30		4	6			
2N2484	A	S	N	360		60	60	50	10n	45	100	500	0.01	150	24K	8	40		3	6			
2N2537	AP	S	N	800		60	30	800	250n	40	50	150	150						8	5			
2N2538	AP	S	N	800		60	30	800	250n	40	100	300	150						8	5			
2N2539	AP	S	N	500		60	30	800	250n	40	50	150	150						8	18			
2N2540	AP	S	N	500		60	30	800	250n	40	100	300	150						8	18			
2N2552	AP	G	P	20W	100	40	40	3A	125	20	20	60	1A						100				
2N2553	AP	G	P	20W	100	60	60	3A	125	30	20	60	1A						100				
2N2554	AP	G	P	20W	100	80	80	3A	125	40	20	60	1A						100				
2N2555	AP	G	P	20W	100	100	100	3A	125	50	20	60	1A						100				
2N2556	AP	G	P	20W	100	40	40	3A	125	20	20	60	1A						100				
2N2557	AP	G	P	20W	100	60	60	3A	125	30	20	60	1A						100				
2N2558	AP	G	P	20W	100	80	80	3A	125	40	20	60	1A						100				
2N2559	AP	G	P	20W	100	100	100	3A	125	50	20	60	1A						100				
2N2560	AP	G	P	20W	100	40	40	3.5A	125	20	20	60	3A						100				

TYPE	TOSHIBA	NEC	HITACHI	MITSUBISHI	MATSUSHITA	FUJITSU	SONY	SANYO	NOTE
A5T2192	2SC485	2SC960	2SC708A		2SC696	7			
2N2193	2SC485	2SC960	2SC708A		2SC696				
2N2193A	2SC485	2SC960	2SC708A		2SC696				
A5T2193	2SC485	2SC960	2SC708A		2SC696				
2N2194	2SC485	2SC960	2SC708A		2SC696				
2N2194A	2SC485	2SC960	2SC708A		2SC696				
2N2217	2SC485	2SC960	2SC708A		2SC696				
2N2218	2SC485	2SC960	2SC708A		2SC696				
2N2218A	2SC485	2SC960	2SC708A		2SC696				
D2T2218	2SC498								
D2T2218A	2SC498								
2N2219	2SC495	2SC960			2SC696				
2N2219A	2SC495	2SC960			2SC696				
D2T2219	2SC498								
D2T2219A	2SC498								
2N2220	2SC503	2SC959		2SC307					
2N2221	2SC503	2SC959		2SC307					
2N2221A	2SC503	2SC959		2SC307					
2N2222	2SC503	2SC959		2SC307					
2N2222A	2SC503	2SC959		2SC307					
Q2T2222	2SC503	2SC959		2SC307					
A5T2222	2SC503	2SC959		2SC307					
2N2223									
2N2223A									
2N2243	2SC510				2SC696A				
2N2243A	2SC510				2SC696A				
A5T2243	2SC510				2SC696A				
2N2270	2SC512				2SC696				
2N2303A	2SA498	2SA606				2SA580			
2N2387		2SC839			2SC644				
2N2388		2SC839			2SC644				
2N2389	2SC497	2SC959							
2N2390	2SC497	2SC959							
2N2393				2SA697	2SA546				
2N2394				2SA697	2SA546				
2N2395	2SC501	2SD227	2SC708		2SC456	2SC1247A			
2N2396	2SC501	2SD227	2SC708		2SC456	2SC1247A			
2N2432	2SC1380A		2SC1345						
2N2432A	2SC1380A		2SC1345						
2N2453	2SC376								
2N2483	2SC788						2SC470		
2N2484	2SC788						2SC470		
2N2537	2SC486				2SC456				
2N2538	2SC486				2SC456				
2N2539	2SC486				2SC456				
2N2540	2SC486				2SC456				
2N2552	2SA490	2SA616						2SB507	
2N2553	2SA490	2SA616						2SB507	
2N2554	2SA489								
2N2555	2SA489								
2N2556	2SA490	2SA616						2SB507	
2N2557	2SA490	2SA616						2SB507	
2N2558	2SA489								
2N2559	2SA489								
2N2560	2SA490	2SA616						2SB507	

TYPE	USE	POLARITY	MATERIAL	MAXIMUM RATINGS							ELECTRICAL CHARACTERISTICS										OUTLINE TO.	NOTE	
				Pc 25°C (mW)	Tj (°C)	Vas (V)	Vcso (V)	Ic (mA)	I _{iso}		h _{FE}		h _{ie}	h _{ie} (Ω)	h _{re} (x10 ⁻⁴)	h _{oe} (Ω)	f _T **f _β (MHz)	NF (dB)	Cob (pF)	Cesrby (ps)			
									(_{z,z} A)	Vos(V)	min.	max.											ic(mA)
2N2561	AP	G	P	20W	100	60	60	3.5A	125	30	20	60	3A							100			
2N2562	AP	G	P	20W	100	80	80	3.5A	125	40	20	60	3A							100			
2N2563	AP	G	P	20W	100	100	100	3.5A	125	50	20	60	3A							100			
2N2564	AP	G	P	20W	100	40	40	3.5A	125	20	20	60	3A							100		5	
2N2565	AP	G	P	20W	100	60	60	3.5A	125	30	20	60	3A							100		5	
2N2566	AP	G	P	20W	100	80	80	3.5A	125	40	20	60	3A							100		5	
2N2567	AP	G	P	20W	100	100	100	3.5A	125	50	20	60	3A							100		5	
2N2586	A	S	N	300	175	60	45	30	2n	45	120	360	10							3		18	DALINGTON
2N2604	A	S	P	400	175	60	45	30	10n	45	40	120	10	60						4	6	46	
A5T 2604	A	S	P	625	150	60	45	30	10n	45	40	120	10	60						4	6		
2N2605	A	S	P	400	175	60	45	30	10n	45	100	300	10	150						3	6	46	
A5T 2605	A	S	P	625	170	60	45	30	10n	45	100	300	10	150						3	6		
2N2639	A	S	N	300		45	45	30	10n	45	50	300	10	65						4	8		1/105
2N2640	A	S	N	300		45	45	30	10n	45	50	300	10	65						4	8		1/105
2N2641	A	S	N	300		45	45	30	10n	45	50	300	10	65						4	8		1/105
2N2642	A	S	N	300		45	45	30	10n	45	100	300	10	130						4	8		1/105
2N2643	A	S	N	300		45	45	30	10n	45	100	300	10	130						4	8		1/105
2N2644	A	S	N	300		45	45	30	10n	45	100	300	10	130						4	8		1/105
2N2659	AP	G	P	15W	100	50	50	3A	125	25	30	90	500							100		5	
2N2660	AP	G	P	15W	100	70	70	3A	125	35	30	90	500							100		5	
2N2661	AP	G	P	15W	100	90	90	3A	125	45	30	90	500							100		5	
2N2662	AP	G	P	15W	100	50	50	3A	125	25	30	90	500							100			
2N2663	AP	G	P	15W	100	70	70	3A	125	35	30	90	500							100			
2N2664	AP	G	P	15W	100	90	90	3A	125	45	30	90	500							100			
2N2665	AP	G	P	15W	100	50	50	3A	125	25	50	150	500							100		5	
2N2666	AP	G	P	15W	100	70	70	3A	125	35	50	150	500							100		5	
2N2667	AP	G	P	15W	100	90	90	3A	125	45	50	150	500							100		5	
2N2668	AP	G	P	15W	100	50	50	3A	125	25	50	150	500							100			
2N2669	AP	G	P	15W	100	70	70	3A	125	35	50	150	500							100			
2N2670	AP	G	P	15W	100	90	90	3A	125	45	50	150	500							100			
2N2802	A	S	P	250		25	20	30	10n	25	20	120	100										1/105
2N2803	A	S	P	250		25	20	30	10n	25	20	120	100										1/105
2N2804	A	S	P	250		25	20	30	10n	25	20	120	100										1/105
2N2805	A	S	P	250		25	20	30	10n	25	40	120	100										1/105
2N2806	A	S	P	250		25	20	30	10n	25	40	120	100										1/105
2N2807	A	S	P	250		25	20	30	10n	25	40	120	100										1/105
2N2880	AP	S	N	30W	200	100	80	5A	0.1	60	40	120	1A										111
2N2894	SW	S	P	360	200	*12	12	200		6	40	150	30										18
2N2904	SW	S	P	600	200	*60	40	600	20n	50	40	120	150										5
D2T 2904	SW	S	P	400	200	60	40	600	20n	50	40	120	150										1/105
2N2904A	SW	S	P	600	200	60	60	600	10n	50	40	120	150										5
D2T 2904A	SW	S	P	400	200	60	60	600	10n	50	40	120	150										1/105
2N2905	SW	S	P	600	200	60	40	600	20n	50	100	300	150										5
D2T 2905	SW	S	P	400	200	60	40	600	20n	50	100	300	150										1/105
O2T 2905	SW	S	P	500	150	60	40	600	20n	50	100	300	150										1/105
2N2905A	SW	S	P	600	200	60	60	600	10n	50	100	300	150										5
2N2906	SW	S	P	400	200	60	40	600	20n	50	40	120	150										18
2N2906A	SW	S	P	400	200	60	60	600	10n	50	40	120	150										18
2N2907	SW	S	P	400	200	60	40	600	20n	50	100	300	150										18
A5T 2907	SW	S	P	625	150	60	40	600	20n	50	100	300	150										1/1
2N2907A	SW	S	P	400	200	60	40	600	10n	50	100	300	150										18
2N2913	A	S	N	300	200	45	45	30	10n	45	60	240	10										1/105
2N2914	A	S	N	300	200	45	45	30	10n	45	150	600	10										1/105
2N2915	A	S	N	300	200	45	45	30	10n	45	60	240	10										1/105
2N2915A	A	S	N	300	200	45	45	30	10n	45	60	240	10										1/105

TYPE	TOSHIBA	NEC	HITACHI	MITSUBISHI	MATSUSHITA	FUJITSU	SONY	SANYO	NOTE
2N2561	2SA489	2SA616			2SB513			2SB509	
2N2562	2SB231	2SA616							
2N2563	2SB231								
2N2564	2SA490	2SA616	2SA670		2SB513			2SB509	
2N2565	2SA489	2SA616			2SB513			2SB509	
2N2566	2SA489	2SA616							
2N2567									
2N2586	2SC979	2SC899	2SC1345	2SC1313					
2N2604	2SC497					2SA523			
A5T2604	2SC497					2SA523			
2N2605	2SC497								
A5T2605	2SC497								
2N2639	2SA502	2SA579					2SA678		
2N2640	2SA502	2SA579					2SA678		
2N2641	2SA502	2SA579					2SA678		
2N2642	2SA502	2SA579					2SA678		
2N2643	2SA502	2SA579					2SA678		
2N2644	2SA502	2SA579					2SA678		
2N2659	2SB434		2SB107A		2SB449			2SB216	
2N2660	2SB503				2SB513			2SB215	
2N2661	2SB502								
2N2662	2SB503	2SA616							
2N2663	2SB503	2SA616							
2N2664	2SB502								
2N2665	2SB503	2SA616							
2N2666	2SB502	2SA616							
2N2667	2SB502								
2N2668	2SB434	2SA616			2SB449				
2N2669	2SB502	2SA616							
2N2670	2SB503								
2N2802	2SA502	2SA578							
2N2803	2SA502	2SA578							
2N2804	2SA502	2SA578							
2N2805	2SA502	2SA578							
2N2806	2SA502	2SA578							
2N2807	2SA502	2SA578							
2N2880	2SC519				2SC697				
2N2894	2SA594		2SA537		2SA546				
2N2904	2SA516	2SA571	2SA537		2SA546				
D2T2904	2SA516				2SA546				
2N2904A	2SA516	2SA571	2SA537		2SA546				
D2T2904A	2SA516				2SA546				
2N2905	2SA516	2SA571	2SA537		2SA546				
D2T2905					2SA546				
Q2T2905					2SA546				
2N2905A		2SA571	2SA537		2SA546				
2N2906		2SA571	2SA537		2SA546				
2N2906A		2SA571	2SA537		2SA546				
2N2907		2SA571	2SA537						
A5T2907		2SA571	2SA537						
2N2907A		2SA571	2SA537						
2N2913	2SC383		2SC984	2SC773					
2N2914	2SC383		2SC984	2SC773					
2N2915	2SC383		2SC984	2SC773					
2N2915A	2SC383		2SC984	2SC773					

TYPE	USE	MATERIAL	POLARITY	MAXIMUM RATINGS							ELECTRICAL CHARACTERISTICS											OUTLINE TO.	NOTE				
				Pc 25°C (mW)	Tj (°C)	V _{DS} (V)	V _{CEO} (V)	I _C (mA)	1000		1hr				hfe	h _{ie} (Ω)	h _{re} (×10)	h _{oe} (μS)	f _T *f ₁₀₀ *f ₁₀₀ (MHz)	NF (dB)	C _{ob} (pF)			C _{omb} (ps)			
									(μA)	V _{CE} (V)	min.	max.	I _C (mA)														
2N2916	A	S	N	300	200	45	45	30	10n	45	150	600	10m											1/105			
2N2916A	A	S	N	300		45	45	30	10n	45	150	600	10m												1/105		
2N2917	A	S	N	300		45	45	30	10n	45	60	240	10m												1/105		
2N2918	A	S	N	300		45	45	30	10n	45	150	600	10m												1/105		
2N2919	A	S	N	300		60	60	30	2n	45	60	240	10m												1/105		
2N2919A	A	S	N	300		60	60	30	2n	45	60	240	10m												1/105		
2N2920	A	S	N	300		60	60	30	2n	45	150	600	10m												1/105		
2N2920A	A	S	N	300		60	60	30	2n	45	150	600	10m												1/105		
2N2944	A	S	P	400		15	10	100	0.1n		80		I												46		
2N2944A	A	S	P	400		15	10	100	0.1n		100		I												46		
2N2945	A	S	P	400		25	20	100	0.2n		40		I												46		
2N2945A	A	S	P	400		25	20	100	0.2n		70		I												46		
2N2946	A	S	P	400		40	35	100	0.5n		30		I												46		
2N2946A	A	S	P	400		40	35	100	0.5n		50		I												46		
2N2972	A	S	N	250		45	45	30	10n	45	60	240	10m												71		
2N2973	A	S	N	250		45	45	30	10n	45	150	600	10m												71		
2N2974	A	S	N	250		45	45	30	10n	45	60	240	10m												71		
2N2975	A	S	N	250		45	45	30	10n	45	150	600	10m												71		
2N2976	A	S	N	250		45	45	30	10n	45	60	240	10m												71		
2N2977	A	S	N	250		45	45	30	10n	45	150	600	10m												71		
2N2978	A	S	N	250		60	60	30	2n	45	60	240	10m												71		
2N2979	A	S	N	250		60	60	30	2n	45	150	600	10m												71		
2N2987	AP	S	N	15W	200	95	80	1A			25	75	200												5		
2N2988	AP	S	N	15W	200	155	100	1A			25	75	200												5		
2N2989	AP	S	N	15W	200	95	80	1A			60	120	200												5		
2N2990	AP	S	N	15W	200	155	100	1A			60	120	200												5		
2N2991	AP	S	N	15W	200	95	80	1A			25	75	200														
2N2992	AP	S	N	15W	200	155	100	1A			25	75	200														
2N2993	AP	S	N	15W	200	95	80	1A			60	120	200														
2N2994	AP	S	N	15W	200	155	100	1A			60	120	200														
2N3012	SW	S	P	360	200	12	12	200			30	120	30				400								18		
2N3015	SW	S	N	800	200	60	30	30	200		30	120	150												5		
2N3021	AP	S	P	25W	175	30	30	3A			20	60	1A												3		
2N3022	AP	S	P	25W	175	45	45	3A			20	60	1A												3		
2N3023	AP	S	P	25W	175	60	60	3A			20	60	1A												3		
2N3024	AP	S	P	25W	175	30	30	3A			20	60	1A												3		
2N3025	AP	S	P	25W	175	45	45	3A			20	60	1A												3		
2N3026	AP	S	P	25W	175	60	60	3A			20	60	1A												3		
2N3036	SW	S	N	800		120	80	1200	10n	60	50	150	150	40	120		120				15				39		
2N3037	SW	S	N	360		120	70	500	10n	60	40	120	150	30	90		100			15				1/179			
2N3038	SW	S	N	360		100	60	500	10n	60	80	240	150	60	180		200			15				1/179			
2N3039	SW	S	P	360		50	35	500	25n	30	20	80	150	20	60		250			40				1/179			
2N3040	SW	S	P	360		40	30	500	25n	30	40	160	150	40	120		500			40				1/179			
2N3043	A	S	N	250		45	45	30	10n	45	100	300	10m												89		
2N3044	A	S	N	250		45	45	30	10n	45	100	300	10m												89		
2N3045	A	S	N	250		45	45	30	10n	45	100	300	10m												89		
2N3046	A	S	N	250		45	45	30	10n	45	50	200	10m												89		
2N3047	A	S	N	250		45	45	30	10n	45	50	200	10m												89		
2N3048	A	S	N	250		45	45	30	10n	45	50	200	10m												89		
2N3049	A	S	P	250		25	20	100	10n	25	30	120	I												89		
2N3050	A	S	P	250		25	20	100	10n	25	30	120	I												89		
2N3051	A	S	P	250		25	20	100	10n	25	30	120	I												89		
2N3052	A	S	N	250		35	15	200	25n	20	25	120	10												89		
2N3053	A	S	N	1W		60	40	700			50	250	150				100								39		
2N3055	AP	S	N	115W	200	100	70	15A			20	70	4A	15											3		

TYPE	TOSHIBA	NEC	HITACHI	MITSUBISHI	MATSUSHITA	FUJITSU	SONY	SANYO	NOTE
2N2916		2SC1330			2SC1360				
2N2916 A		2SC1330			2SC1360				
2N2917		2SC1330			2SC1360				
2N2918		2SC1330			2SC1360				
2N2919	2SC979			2SC714		2SC205			
2N2919 A	2SC979			2SC714		2SC205			
2N2920	2SC979			2SC714		2SC205			
2N2920 A	2SC979			2SC714		2SC205			
2N2944		2SA643							
2N2944 A		2SA643	2SA741						
2N2945		2SA643	2SA741						
2N2945 A		2SA643	2SA741						
2N2946		2SA643	2SA741						
2N2946 A		2SA643	2SA741						
2N2972	2SC979		2SA741	2SC714		2SC205			
2N2973	2SC979			2SC714		2SC205			
2N2974	2SC979			2SC714		2SC205			
2N2975	2SC979			2SC714		2SC205			
2N2976	2SC979			2SC714		2SC205			
2N2977	2SC979			2SC714		2SC205			
2N2978	2SC979			2SC714		2SC205			
2N2979	2SC979			2SC714		2SC205			
2N2987	2SC488								
2N2988	2SC488								
2N2989	2SC488								
2N2990	2SC488								
2N2991	2SC488								
2N2992	2SC488								
2N2993	2SC488								
2N2994	2SC488								
2N3012			2SA537		2SA546				
2N3015	2SC503	2SC959							
2N3021	2SA490	2SA616						2SB509	
2N3022	2SA490	2SA616						2SB509	
2N3023	2SA489	2SA616						2SB509	
2N3024	2SA490	2SA616						2SB509	
2N3025	2SA490	2SA616						2SB509	
2N3026	2SA489	2SA616						2SB509	
2N3036	2SC484								
2N3037	2SC1382								
2N3038	2SC1382								
2N3039		2SA606	2SA537		2SA546	2SA580			
2N3040		2SA606	2SA537		2SA546	2SA580			
2N3043	2SC979					2SC205			
2N3044	2SC979			2SC714		2SC205			
2N3045	2SC979			2SC714		2SC205			
2N3046	2SC979			2SC714		2SC205			
2N3047	2SC979			2SC714		2SC205			
2N3048	2SC979			2SC714		2SC205			
2N3049				2SC714					
2N3050		2SA711							
2N3051		2SA711							
2N3052	2SC979					2SC205			
2N3053		2SC959		2SC714	2SC456				
2N3055	2SC1080		2SC1343						

TYPE	USE	MATERIAL	POLARITY	MAXIMUM RATINGS											ELECTRICAL CHARACTERISTICS											OUTLINE TO.	NOTE
				Pc 25°C (mW)	Tj (°C)	V _{ce} (V)	V _{ceo} (V)	I _c (mA)	I _o		h _{FE}			h _{FE}	h _{FE} (Ω)	h _{FE} (×10)	h _{FE} (μC)	f _r 100 ***f ₀ (MHz)	NF (dB)	C _{ob} (pF)	C _{omb} (ps)						
									(μA)	V _{ce} (V)	min.	max.	I _c (mA)														
2N3114	AH	S	N	800		150	150	200	10n	100	30	120	30								39						
2N3117	A	S	N	360		60	60	50	10n	45	250	500	10M	400	10K	8	40				4	18					
2N3146	AP	G	P	150W	100	150	140	15A	10mA	150	30	90	5A	20								3					
2N3147	AP	G	P	150W	100	180	160	15A	10mA	180	30	90	5A	20								3					
2N3244	A	S	P	1W		40	40	1A	50n	30	50	150	500							175		39					
2N3245	A	S	P	1W		50	50	1A	50n	50	30	90	500							150		39					
2N3250	SW	S	P	360	200	50	40	200			50	150	10	50	6K	10	10	250				18					
2N3250A	SW	S	P	360	200	60	60	200			50	150	10	50	6K	10	10	250				18					
2N3251	SW	S	P	360	200	50	40	200			100	300	10	100	12K	10	60	300				18					
2N3251A	SW	S	P	360	200	60	60	200			100	300	10	100	12K	10	60	300				18					
2N3252	SW	S	N	1W	200	60	30	1A	0.5	40	30	90	500							200		39					
2N3253	SW	S	N	1W	200	75	40	1A	0.5	60	25	75	500							175		39					
2N3263	PAH	S	N	83W	200	150	90	25A			20	55	15A							20		39					
2N3264	PAH	S	N	83W	200	120	60	25A			20	55	15A							20		39					
2N3265	PAH	S	N	125W	200	150	90	25A			20	80	15A							20		63					
2N3266	PAH	S	N	125W	200	120	60	25A			20	80	15A							20		63					
2N3347	A	S	P	300		60	45	30	10n	45	40	300	10M									105					
2N3348	A	S	P	300		60	45	30	10n	45	40	300	10M									105					
2N3349	A	S	P	300		60	45	30	10n	45	40	300	10M									105					
2N3350	A	S	P	300		60	45	30	10n	45	100	300	10M									105					
2N3351	A	S	P	300		60	45	30	10n	45	100	300	10M									105					
2N3352	A	S	P	300		60	45	30	10n	45	100	300	10M									105					
A5T3391	AH	S	N	625	150	25	25	100	100n	25	250	400	2									39					
A7T3391	AH	S	N	625	150	25	25	100	100n	25	250	400	2									39					
A8T3391	AH	S	N	625	150	25	25	100	100n	25	250	400	2									39					
A5T3391A	AH	S	N	625	150	25	25	100	100n	25	250	400	2							5		39					
A7T3391A	AH	S	N	625	150	25	25	100	100n	25	250	400	2							5		39					
A8T3391A	AH	S	N	625	150	25	25	100	100n	25	250	400	2							5		39					
A5T3392	AH	S	N	625	150	25	25	100	100n	25	150	300	2									39					
A7T3392	AH	S	N	625	150	25	25	100	100n	25	150	300	2									39					
A8T3392	AH	S	N	625	150	25	25	100	100n	25	150	300	2									39					
2N3418	AP	S	N	15W	200	85	60	3A			20	60	1							40		5					
2N3419	AP	S	N	15W	200	125	80	3A			20	60	1							40		5					
2N3420	AP	S	N	15W	200	80	60	3A			40	120	1							40		5					
2N3421	AP	S	N	15W	200	125	80	3A			40	120	1							40		5					
2N3439	AP	S	N	5W	200	450	350	1A	2	360	40	160	20							15		5					
2N3440	AP	S	N	5W	200	300	250	1A	2	250	40	160	20							15		5					
2N3444	SW	S	N	5W	200	80	50	1A	0.5	60	20	60	500							150		39					
2N3467	AP	S	P	1W		40	40	1A	100n	30	40	120	500							175		39					
2N3468	AP	S	P	1W		50	50	1A	100n	30	25	75	500							150		39					
2N3485	SW	S	P	400		60	40	600	20n	50	40	120	150									46					
2N3485A	SW	S	P	400		60	40	600	10n	50	40	120	150									46					
2N3486	SW	S	P	400		60	40	600	20n	50	10	300	150									46					
2N3486A	SW	S	P	400		60	40	600	10n	50	10	300	150									46					
2N3494	SW	S	P	600	200	80	80	100	0.1	50	40	10										5					
2N3495	SW	S	P	600	200	120	120	100	0.1	90	40	10										5					
2N3496	SW	S	P	400	200	80	80	100	0.1	50	40	10										18					
2N3497	SW	S	P	400	200	120	120	100	0.1	90	40	10										18					
A5T3496	SW	S	P	625	150	80	80	100	0.1	50	40	10										39					
A5T3497	SW	S	P	625	150	120	120	100	0.1	90	40	10										39					
2N3502	SW	S	P	700	200	45	45	600	10	30	100	300	150	135	23K	15	800			4		5					
2N3503	SW	S	P	700	200	60	60	600	10	50	100	300	150	135	23K	15	800			4		5					
2N3504	SW	S	P	400	200	45	45	600	10	30	100	300	150	135	23K	15	800			4		18					
2N3505	SW	S	P	400	200	60	60	600	10	50	100	300	150	135	23K	15	800			4		18					
A5T3404	SW	S	P	625	150	45	45	600	10	30	100	300	150	135	23K	15	800			4		39					

TYPE	TOSHIBA	NEC	HITACHI	mitsubishi	MATSUSHITA	FUJITSU	SONY	SANYO	NOTE
2N3114		2SC1217							
2N3117	2SC788					2SC727			
2N3146							2SB520		
2N3147							2SB520		
2N3244							2SA706		
2N3245							2SA706		
2N3250		2SA504			2SA546A	2SA558			
2N3250A		2SA504			2SA546A				
2N3251		2SA504			2SA546A	2SA558			
2N3251A		2SA504			2SA546A				
2N3252	2SC485				2SC696				
2N3253	2SC485				2SC696				
2N3263	2SC1435					2SC1301			
2N3264	2SC1435					2SC1301			
2N3265	2SC1435					2SC1301			
2N3266	2SC1435					2SC1301			
2N3347	2SA502	2SA675					2SA678		
2N3348	2SA502	2SA675					2SA678		
2N3349	2SA502	2SA675					2SA678		
2N3350	2SA502	2SA675					2SA678		
2N3351	2SA502	2SA675					2SA678		
2N3352	2SA502	2SA675					2SA678		
A5T3391				2SC442		2SC202			
A7T3391				2SC442		2SC202			
A8T3391				2SC442		2SC202			
A5T3391A				2SC442		2SC202			
A7T3391A				2SC442		2SC202			
A8T3391A				2SC442		2SC202			
A5T3392				2SC442		2SC202			
A7T3392				2SC442		2SC202			
A8T3392				2SC442		2SC202			
2N3418			2SC1055						
2N3419			2SC1055						
2N3420			2SC1055						
2N3421			2SC1055						
2N3439					2SD198	2SC825	2SC895-3		
2N3440					2SD198	2SC825	2SC895-3		
2N3444								2SC614	
2N3467							2SA706		
2N3468							2SA706		
2N3485		2SA606	2SA537			2SA580			
2N3485A		2SA606	2SA537			2SA580			
2N3486		2SA606	2SA537			2SA580			
2N3486A		2SA606	2SA537			2SA580			
2N3494		2SA712							
2N3495		2SA712							
2N3496		2SA712							
2N3497		2SA712							
A5T3496		2SA712							
A5T3497		2SA712							
2N3502		2SA606	2SA537			2SA580			
2N3503		2SA606	2SA537			2SA580			
2N3504		2SA606	2SA537			2SA580			
2N3505		2SA606	2SA537			2SA580			
A5T3404		2SA606	2SA537			2SA580			

TYPE	USE	MATERIAL	POLARITY	MAXIMUM RATINGS				ELECTRICAL CHARACTERISTICS													OUTLINE TO.	NOTE		
				Pc 25°C (mW)	Tj (°C)	Vas (V)	Vcco (V)	Ic (mA)	I _{iso}		hFE		hfe	hie (Ω)	hre (×10)	hoe (μΩ)	f _T *f _{osc} **f _{ob} (MHz)	NF (dB)	Cob (pF)	Coxob _b (ps)				
									(μA)	Vos(V)	min.	max.											Ic(mA)	
A5T3405	SW	S	P	625	150	60	60	600	10	50	100	300	150	135	23K	15	800		4					1/2
2N3551	AP	S	N	40W	175	115	60	12A			20	90	10A											1/2
2N3552	AP	S	N	40W	175	140	80	12A			20	90	10A											3/21
2N3554	SW	S	N	800	200	60	30	1.2A			25	100	750											39
A5T3565	A	S	N	625	150	30	25	50	50n	25	150	600	1	120	20K		100							1/2
2N3570	AH	S	N	200	150	30	15	50	10n	6	20	150	5				1.5G	1GNZ						72
2N3571	AH	S	N	200	150	25	15	50	10n	6	20	200	5				1.5G	1GNZ						72
2N3572	AH	S	N	200	150	25	13	50	10n	6	20	300	5				1.5G	1GNZ						72
A5T3571	AH	S	N	500	150	25	15	50	10n	6	20	200	5				1.5G	1GNZ						1/2
A5T3572	AH	S	N	500	150	25	13	50	10n	6	20	300	5				1.5G	1GNZ						1/2
2N3576	AH	S	P	360	200	20	15	200			40	120	10				400							18
2N3583	AP	S	N	35W	200	250	175	1A			40	200	500											66
2N3584	AP	S	N	35W	200	375	250	2A			8	80	1A											66
2N3585	AP	S	N	35W	200	500	300	2A			8	80	1A											66
2N3634	SW	S	P	1W	200	140	140	1A	100n	100	50	150	50	40	0.6K	3	200			10				39
2N3635	SW	S	P	1W	200	140	140	1A	100n	100	100	300	50	80	1.2K	3	200			10				39
2N3636	SW	S	P	1W	200	175	175	1A	100n	100	50	150	50	40	0.6K	3	200			10				39
2N3637	SW	S	P	1W	200	175	175	1A	100n	100	100	300	50	80	1.2K	3	200			10				39
A5T3638	SW	S	P	625	150	25	25	500			20	10	25	2K	26	1.2			20					1/2
A5T3638A	SW	S	P	625	150	25	25	500			100	100	100	100	2K	15	1.2			10				1/2
A5T3644	SW	S	P	625	150	45	45	600			100	300	150	100	1.8K	3	300			8				1/2
A5T3645	SW	S	P	625	150	60	60	600			100	300	150	100	1.8K	3	300			8				1/2
2N3680	A	S	N	300		60	50	30	10n	4.5	150	600	10μ											1/205
2N3702	A	S	P	360	150	40	25	200	100n	20	60	300	50				100							1/2
A8T3702	A	S	P	625	150	40	25	200	100n	20	60	300	50				100							1/2
2N3703	A	S	P	360	150	50	30	200	100n	20	30	150	50				100							1/2
A8T3703	A	S	P	625	150	50	30	200	100n	20	30	150	50				100							1/2
2N3704	A	S	N	360	150	50	30	800	100n	20	100	300	50				100							1/2
A8T3704	A	S	N	625	150	50	30	800	100n	20	100	300	50				100							1/2
2N3705	A	S	N	360	150	50	30	800	100n	20	50	150	50				100							1/2
A8T3705	A	S	N	625	150	50	30	800	100n	20	50	150	50				100							1/2
2N3706	A	S	N	360	150	40	20	800	100n	20	30	600	50				100							1/2
A8T3706	A	S	N	625	150	40	20	800	100n	20	30	600	50				100							1/2
2N3707	A	S	N	360	150	30	30	30	100n	20	100	400	0.1						1.9					1/2
A5T3707	A	S	N	625	150	30	30	30	100n	20	100	400	0.1						1.9					1/2
A8T3707	A	S	N	625	150	30	30	30	100n	20	100	400	0.1						1.9					1/2
2N3708	A	S	N	360	150	30	30	30	100n	20	45	660	1											1/2
A5T3708	A	S	N	625	150	30	30	30	100n	20	45	660	1											1/2
A8T3708	A	S	N	360	150	30	30	30	100n	20	45	660	1											1/2
2N3709	A	S	N	625	150	30	30	30	100n	20	45	165	1											1/2
A5T3709	A	S	N	360	150	30	30	30	100n	20	45	165	1											1/2
A8T3709	A	S	N	625	150	30	30	30	100n	20	45	165	1											1/2
2N3710	A	S	N	360	150	30	30	30	100n	20	90	330	1											1/2
A5T3710	A	S	N	625	150	30	30	30	100n	20	90	330	1											1/2
A8T3710	A	S	N	360	150	30	30	30	100n	20	90	330	1											1/2
2N3711	A	S	N	625	150	30	30	30	100n	20	180	660	1											1/2
A5T3711	A	S	N	625	150	30	30	30	100n	20	180	660	1											1/2
A8T3711	A	S	N	360	150	30	30	30	100n	20	180	660	1											1/2
2N3713	AP	S	N	150W	200	80	60	10A			25	75	1A				4							3
2N3714	AP	S	N	150W	200	100	80	10A			25	75	1A				4							3
2N3715	AP	S	N	150W	200	80	60	10A			50	150	1A				4							3
2N3716	AP	S	N	150W	200	100	80	10A			50	150	1A				4							3
2N3719	AP	S	P	6W	200	40	40	3A	10	40	25	180	1A											5
2N3720	AP	S	P	6W	200	60	60	3A	10	60	25	180	1A											5
2N3724	A	S	N	800	200	50	30	500	1.7	40	60	150	100											39

TYPE	TOSHIBA	NEC	HITACHI	MITSUBISHI	MATSUSHITA	FUJITSU	SONY	SANYO	NOTE
A5T3405		2SA606			2SA546	2SA580			
2N3551		2SD181	2SD341						
2N3552		2SD181							
2N3554					2SC696		2SC1124		
A5T3565		2SC852				2SC1068			
2N3570		2SC852		2SC1223		2SC1068			
2N3571		2SC852		2SC1223		2SC1068			
2N3572		2SC852		2SC1223		2SC1068			
A5T3571		2SC852		2SC1223		2SC1068			
A5T3572		2SC852		2SC1223		2SC1068			
2N3576	2SA467		2SA537		2SA546				
2N3583	2SC792								
2N3584	2SC792					2SC1463			
2N3585						2SC1463			
2N3634	2SA516A						2SA762		
2N3635	2SA516A						2SA762		
2N3636									
2N3637									
A5T3638	2SA496	2SA717	2SA537	2SA695	2SA546	2SA580		2SA532	
A5T3638A	2SA496	2SA717	2SA537	2SA695	2SA546	2SA580		2SA532	
A5T3644	2SA594				2SA546				
A5T3645	2SA594				2SA546				
2N3680									
2N3702	2SA509G	2SA643							
A8T3702	2SA509G	2SA643							
2N3703	2SA498	2SA544							
A8T3703	2SA498	2SA544							
2N3704	2SC498					2SC1247A			
A8T3704	2SC498					2SC1247A			
2N3705	2SC498					2SC1247A			
A8T3705	2SC498					2SC1247A			
2N3706	2SC498					2SC1247A			
A8T3706	2SC498					2SC1247A			
2N3707	2SC509					2SC1246			
A5T3707	2SC509					2SC1246			
A8T3707	2SC509					2SC1246			
2N3708	2SC509					2SC1246			
A5T3708	2SC509					2SC1246			
A8T3708	2SC509					2SC1246			
2N3709	2SC509					2SC1246			
A5T3709	2SC509					2SC1246			
A8T3709	2SC509					2SC1246			
2N3710	2SC509					2SC1246			
A5T3710	2SC509					2SC1246			
A8T3710	2SC509					2SC1246			
2N3711	2SC509					2SC1246			
A5T3711	2SC509					2SC1246			
A8T3711	2SC509					2SC1246			
2N3713	2SC1080		2SC1343				2SD340		
2N3714	2SC1079		2SC1343				2SD340		
2N3715	2SC1080		2SC1343				2SD340		
2N3716	2SC1079		2SC1343				2SD340		
2N3719	2SA490	2SA616							
2N3720	2SA490	2SA616							
2N3724			2SC1212						

TYPE	USE	MATERIAL	POLARITY	MAXIMUM RATINGS						ELECTRICAL CHARACTERISTICS										OUTLINE TO.	NOTE							
				Pc 25°C (mW)	Tj (°C)	Vos (V)	Vcso (V)	Ic (mA)	I _{iso} (μA)	hFE		I _{oe} (Ω)	I _{re} (×10)	hoe (μS)	f _T (MHz)	NF (dB)	Cob (pF)	Costr (ps)										
2N3724A	A	S	N	1W	200	50	30	1200	0.5	40	60	150	100												39			
2N3725	A	S	N	800	200	80	50	500	1.7	60	60	150	100													39		
2N3725A	A	S	N	1W	200	80	50	1200	0.5	60	60	150	100													39		
Q2T3725	A	S	N	500	150	60		500																				
2N3734	A	S	N	1W	200	50	30	1500			30	120	1A													39		
2N3735	A	S	N	1W	200	75	50	1500			20	80	1A													39		
2N3771	AP	S	N	150W	200	50	40	30A	2mA	50	15	60	15A													3		
2N3772	AP	S	N	150W	200	100	60	20A	5mA	100	15	60	10A													3		
2N3789	AP	S	P	150W	200	60	60	10A			25	90	1A					4								3		
2N3790	AP	S	P	150W	200	80	80	10A			25	90	1A					4								3		
2N3791	AP	S	P	150W	200	60	60	10A			50	180	1A					4								3		
2N3792	AP	S	P	150W	200	80	80	10A			50	180	1A					4								3		
2N3798	A	S	P	360	200	60	60	50	10n	50	50	450	0.5	150	30K	25	60			3.5	4					18		
2N3799	A	S	P	360	200	60	60	50	10n	50	300	900	0.5	300	40K	25	60			2.5	4					18		
2N3806	A	S	P	500		60	60	50	10n	50	150	450	0.5													1/105		
2N3807	A	S	P	500		60	60	50	10n	50	300	900	0.5													1/105		
2N3808	A	S	P	500		60	60	50	10n	50	150	450	0.5													1/105		
2N3809	A	S	P	500		60	60	50	10n	50	300	900	0.5													1/105		
2N3810	A	S	P	500		60	60	50	10n	50	150	450	0.5													1/105		
2N3811	A	S	P	500		60	60	50	10n	50	300	900	0.5													1/105		
2N3829	AH	S	P	360	200	35	20	200			30	120	30					350								52		
2N3838	A	S	P	250		60	40	600			100	300	150															
2N3846	AP	S	N	150W	175	300	200	20A			10	60	10A					10									63	
2N3847	AP	S	N	150W	175	400	300	20A			10	60	10A					10									63	
2N3902	AP	S	N	100W	150		400	2.5A			30	90	1A					5									63	
2N3903	AH	S	N	625	150	60	40	200			50	150	10	50	8K	5	40	250			4					1/1		
A5T3903	AH	S	N	625	150	60	40	200			50	150	10	50	8K	5	40	250			4					1/1		
2N3904	AH	S	N	625	150	60	40	200			100	300	10	100	10K	8	40	300			4					1/1		
A5T3904	AH	S	N	625	150	60	40	200			100	300	10	100	10K	8	40	300			4					1/1		
2N3905	AH	S	P	625	150	40	40	200			50	150	10	50	8K	5	40	200			4					1/1		
A5T3905	AH	S	P	625	150	40	40	200			50	150	10	50	8K	5	40	200			4					1/1		
2N3906	AH	S	P	625	150	40	40	200			100	300	10	100	10K	8	40	250			4					1/1		
A5T3906	AH	S	P	625	150	40	40	200			100	300	10	100	10K	8	40	250			4					1/1		
2N3962	A	S	P	360	200	60	60	200	10n	50	100	300	10M	100	17K	10	40			3	6					18		
2N3963	A	S	P	360	200	80	80	200	10n	70	100	300	10M	100	17K	10	40			3	6					18		
2N3964	A	S	P	360	200	45	45	200	10n	40	250	500	10M	250	20K	10	50			2	6					18		
2N3965	A	S	P	360	200	60	60	200	10n	50	250	500	10M	250	20K	10	50			2	6					18		
2N3996	APH	S	N	30W	200	100	80	5A			40	120	1A					40								111		
2N3997	APH	S	N	30W	200	100	80	5A			80	240	1A					40								111		
2N3998	APH	S	N	30W	200	100	80	5A			40	120	1A					40								111		
2N3999	APH	S	N	30W	200	100	80	5A			80	240	1A					40								111		
2N4000	APH	S	N	15W	200	100	80	1A			30	120	500					40								5		
2N4001	APH	S	N	15W	200	120	100	1A			40	120	500					40								5		
2N4002	APH	S	N	100W	200	100	80	30A			20	80	15A													63		
2N4003	APH	S	N	100W	200	120	100	30A			20	80	15A													63		
2N4004	APH	S	N	40W	200	100	80	20A			30	150	10A													1/15		
2N4005	APH	S	N	40W	200	120	100	20A			30	150	10A													1/15		
2N4013	A	S	N	360		60	40	500	1.7	40	60	150	100													18		
2N4014	A	S	N	360		80	50	500	1.7	60	60	150	100													18		
2N4026	A	S		500	200	60	60	1	50n	50	40	120	100														18	
A5T4026	A	S	P	625	150	60	60	1	50n	50	40	120	100														1/1	
A8T4026	A	S	P	625	150	60	60	1	50n	50	40	120	100														1/1	
2N4027	A	S	P	500	200	80	80	1	50n	60	40	120	100														18	
A5T4027	A	S	P	625	150	80	80	1	50n	60	40	120	100														1/1	
A8T4027	A	S	P	625	150	80	80	1	50n	60	40	120	100														1/1	

TYPE	TOSHIBA	NEC	HITACHI	mitsubishi	MATSUSHITA	FUJITSU	SONY	SANYO	NOTE
2N3724A	2SC485								
2N3725	2SC485								
2N3725A	2SC485								
Q2T3725	2SC485				2SC456	2SC1247			
2N3734	2SC485				2SC696A			2SC614	
2N3735	2SC485				2SC696A			2SC614	
2N3771	2SD114					2SD250			
2N3772	2SD113								
2N3789	2SA680								
2N3790	2SA679								
2N3791	2SA680								
2N3792	2SA679								
2N3798					2SA731				
2N3799					2SA731				
2N3806					2SA731				
2N3807					2SA731				
2N3808					2SA731				
2N3809					2SA731				
2N3810					2SA731				
2N3811					2SA731				
2N3829	2SA594G								
2N3838	2SA682								
2N3846	2SC1434								
2N3847	2SC1434								
2N3902		2SC1106							
2N3903	2SC498	2SC729							
A5T3903	2SC498	2SC729							
2N3904	2SC498	2SC729							
A5T3904	2SC498	2SC729							
2N3905	2SA503				2SA546			2SA532	
A5T3705	2SA503				2SA546			2SA532	
2N3906	2SA503				2SA546			2SA532	
A5T3906	2SA503				2SA546			2SA532	
2N3962	2SA503	2SC729							
2N3963	2SA503	2SC729							
2N3964	2SA503	2SC729							
2N3965	2SA503	2SC729							
2N3996	2SC981		2SC105						
2N3997	2SC981		2SC105						
2N3998	2SC981		2SC105						
2N3999	2SC981		2SC105						
2N4000		2SC1161	2SC1409						
2N4001		2SC1161	2SC1409						
2N4002	2SC1435					2SC1301			
2N4003	2SC1435					2SC1301			
2N4004	2SC1435					2SC1301			
2N4005	2SC1435					2SC1301			
2N4013					2SC456	2SC1247			
2N4014	2SC497								
2N4026	2SA485				2SA546 A				
A5T4026	2SA485				2SA546 A				
A8T4026	2SA485				2SA546 A				
2N4027	2SA485				2SA546 A				
A5T4027	2SA485				2SA546 A				
A8T4027	2SA485				2SA546 A				

TYPE	USE	MATERIAL	POLARITY	MAXIMUM RATINGS				ELECTRICAL CHARACTERISTICS														OUTLINE TO.	NOTE						
				Pc 25°C (mW)	Tj (°C)	Voa (V)	Vcoo (V)	Ic (mA)	I _{iso}		h _{FE}				hfe	hie (Ω)	hre (×10)	hoe (μs)	f _T *f _{ce} *f _{cb} (MHz)	NF (dB)	Cob (pF)			Coxbo (ps)					
									(μA)	V _{CE} (V)	min.	max.	Ic(mA)																
2N4028	A	S	P	500	200	60	60	1A	50n	50	100	300	100													18			
A5T4028	A	S	P	625	150	60	60	1A	50n	50	100	300	100													18			
A8T4028	A	S	P	625	150	60	60	1A	50n	50	100	300	100													18			
2N4029	A	S	P	500	200	80	80	1A	50n	60	100	300	100													18			
A5T4029	A	S	P	625	150	80	80	1A	50n	60	100	300	100													18			
A8T4029	A	S	P	625	150	80	80	1A	50n	60	100	300	100													18			
2N4030	A	S	P	800	200	60	60	1A	50n	50	40	120	100													39			
2N4031	A	S	P	800	200	80	80	1A	50n	60	40	120	100													39			
2N4032	A	S	P	800	200	60	60	1A	50n	50	100	300	100													39			
2N4033	A	S	P	800	200	80	80	1A	50n	60	100	300	100													39			
2N4058	A	S	P	625	150	30	30	30	100n	20	100	400	0.1													1.7	18		
A5T4058	A	S	P	625	150	30	30	30	100n	20	100	400	0.1													1.7	18		
A8T4058	A	S	P	625	150	30	30	30	100n	20	100	400	0.1													1.7	18		
2N4059	A	S	P	625	150	30	30	30	100n	20	45	660	1													18			
A5T4059	A	S	P	625	150	30	30	30	100n	20	45	660	1													18			
A8T4059	A	S	P	625	150	30	30	30	100n	20	45	660	1													18			
2N4060	A	S	P	625	150	30	30	30	100n	20	45	165	1													18			
A5T4060	A	S	P	625	150	30	30	30	100n	20	45	165	1													18			
A8T4060	A	S	P	625	150	30	30	30	100n	20	45	165	1													18			
2N4061	A	S	P	625	150	30	30	30	100n	20	90	330	1													18			
A5T4061	A	S	P	625	150	30	30	30	100n	20	90	330	1													18			
A8T4061	A	S	P	625	150	30	30	30	100n	20	90	330	1													18			
2N4062	A	S	P	625	150	30	30	30	100n	20	180	660	1													18			
A5T4062	A	S	P	625	150	30	30	30	100n	20	180	660	1													18			
A8T4062	A	S	P	625	150	30	30	30	100n	20	180	660	1													18			
2N4104	A	S	N	300	200	60	60	50	10n	45	400	800	10M	500	42K	8	60									4.5	18		
2N4123	AH	S	N	625	150	40	30	200	50n	20	50	150	2													250	18		
A5T4123	AH	S	N	625	150	40	30	200	50n	20	50	150	2													250	18		
2N4124	AH	S	N	625	150	40	30	200	50n	20	120	360	2													300	18		
A5T4124	AH	S	N	625	150	30	25	200	50n	20	120	360	2													300	18		
2N4125	AH	S	P	625	150	30	30	200	50n	20	150	150	2													200	18		
A5T4125	AH	S	P	625	150	30	30	200	50n	20	120	360	2													250	18		
2N4126	AH	S	P	625	150	25	25	200	50n	20	120	360	2													250	18		
A5T4126	AH	S	P	625	150	25	25	200	50n	20	120	360	2													250	18		
2N4138	A	S	N	300		30	30	100	10n	25	30		10M														46		
A5T4248	A	S	P	625	150	40	40	100	10n	40	50		0.1	50													18		
A5T4249	A	S	P	625	150	60	60	100	10n	40	100	300	0.1	100	17K	10	40									3	18		
A5T4250	A	S	P	625	150	40	40	100	10n	40	250	750	0.1	250	20K	10	50									2	18		
2N4252	AH	S	N	200		30	18	50	50n	15	50		2														72		
2N4253	AH	S	N	200		30	18	50	50n	15	30	150	2														72		
2N4260	AH	S	P	200	200	15	15	30			30	150	10													1.2GHz	72		
A5T4260	AH	S	P	500	150	15	15	30			30	150	10													1.2GHz	72		
2N4261	AH	S	P	200	200	15	15	30			30	150	10													1.5GHz	72		
A5T4261	AH	S	P	500	150	15	15	30			30	150	10														72		
2N4300	APH	S	N	15W	200	100	80	2A			30	120	1A													30	5		
2N4301	APH	S	N	50W	200	100	80	10A			30	120	5A													40	61		
2N4398	APH	S	P	200W	200	40	40	30A			15	60	15A													4	3		
2N4399	APH	S	P	200W	200	60	60	30A			15	60	15A													4	3		
2N4402	AH	S	P	625	150	40	40	600			50	150	150	30	7.5K	8	100										18		
A5T4402	AH	S	P	625	150	40	40	600			50	150	150	30	7.5K	8	100										18		
2N4403	AH	S	P	625	150	40	40	600			100	300	150	60	15K	8	100										18		
A5T4403	AH	S	P	625	150	40	40	600			100	300	150	60	15K	8	100										18		
2N4409	A	S	N	625	150	80	50	250	10n	60	60	400	100														18		
A5T4409	A	S	N	625	150	80	50	250	10n	60	60	400	100														18		
2N4410	A	S	N	625	150	120	80	250	10n	100	60	400	100														18		

TYPE	TOSHIBA	NEC	HITACHI	MITSUBISHI	MATSUSHITA	FUJITSU	SONY	SANYO	NOTE
2N4028	2SA681	2SA717	2SA537A		2SA546				
A5T4028	2SA681	2SA717	2SA537A		2SA546				
A8T4028	2SA681	2SA717	2SA537A		2SA546				
2N4029	2SA681	2SA708	2SA537A		2SA546				
A5T4029	2SA681	2SA708	2SA537A		2SA546				
A8T4029	2SA681	2SA708	2SA537A		2SA546				
2N4030	2SA681	2SA717	2SA537A		2SA546				
2N4031	2SA681	2SA708	2SA537A		2SA546				
2N4032	2SA681	2SA717	2SA537A		2SA546				
2N4033	2SA681	2SA708	2SA537A		2SA546				
2N4058	2SA509	2SA643		2SA9696					
A5T4058	2SA509	2SA643		2SA9696					
A8T4058	2SA509	2SA643		2SA9696					
2N4059	2SA509	2SA643		2SA9696					
A5T4059		2SA643		2SA9696					
A8T4059	2SA509	2SA643		2SA9696					
2N4060	2SA509	2SA643		2SA9696					
A5T4060	2SA509	2SA643		2SA9696					
A8T4060	2SA509	2SA643		2SA9696					
2N4061	2SA509	2SA643		2SA9696					
A5T4061	2SA509	2SA643		2SA9696					
A8T4061	2SA509	2SA643		2SA9696					
2N4062	2SA509	2SA643		2SA9696					
A5T4062	2SA509	2SA643		2SA9696					
A8T4062	2SA509	2SA643		2SA9696					
2N4104	2SC559	2SC945				2SC725			
2N4123	2SC998	2SC578		2SC730	2SC456	2SC202		2SC423	
A5T4123	2SC998	2SC578		2SC730	2SC456	2SC202		2SC423	
2N4124	2SC998	2SC578		2SC730	2SC456	2SC202		2SC423	
A5T4124	2SC509	2SC578		2SC730	2SC456	2SC202		2SC423	
2N4125	2SA661	2SA643			2SA546	2SA558		2SA532	
A5T4125	2SA661	2SA643							
2N4126	2SA661	2SA643			2SA546	2SA558		2SA532	
A5T4126	2SA661	2SA643			2SA546	2SA558		2SA532	
2N4138		2SC945	2SC1204	2SC422					
A5T4248	2SA661								
A5T4249	2SA661								
A5T4250	2SA661								
2N4252			2SC460	2SC710		2SC964	2SC1128		
2N4253			2SC460	2SC710		2SC964	2SC1128		
2N4260	2SA561		2SA530			2SA558		2SC532	
A5T4260	2SA561					2SA558		2SC532	
2N4261	2SA561		2SA530			2SA558		2SC532	
A5T4261	2SA561					2SA558		2SC532	
2N4300		2SC1160			2SC697		2SC756		
2N4301	2SC1079								
2N4398									
2N4399									
2N4402	2SA504	2SA606	2SA742			2SA580			
A5T4402	2SA504	2SA606	2SA742			2SA580			
2N4403	2SA504	2SA606	2SA742			2SA580			
A5T4403	2SA504	2SA606	2SA742			2SA580			
2N4409	2SC1166	2SC853				2SC826			
A5T4409	2SC1166	2SC853				2SC826			
2N4410				2SC310		2SC826			

TYPE	USE	MATERIAL	POLARITY	MAXIMUM RATINGS					ELECTRICAL CHARACTERISTICS											OUTLINE TO.	NOTE			
				Pc 25°C (mW)	Tj (°C)	V _{DS} (V)	V _{CEO} (V)	I _C (mA)	I _{CEO}		h _{FE}			h _{FE} (Ω)	h _{FE} (×10 ⁴)	h _{FE} (μS)	f _T #128 #129 (MHz)	NF (dB)	C _{ob} (pF)			C _{oxb} (ps)		
									(μA)	V _{CE} (V)	min	max	I _C (mA)											
A5T4410	A	S	N	625	150	120	80	250	10n	100	60	400	10										1/17	
2N4423	AH	S	P	360	150	12	12	200	1	6	40	150	30										1/17	
2N4854	SW	S	N	300	200	60	40	600	10n	50	100	300	150										1/105	
2N4855	SW	S	N	300	200	60	40	600	10n	50	40	120	150										1/105	
2N4901	AP	S	P	87.5W	200	40	40	5A			20	80	1A			4							3	
2N4902	AP	S	P	87.5W	200	60	60	5A			20	80	1A			4							3	
2N4903	AP	S	P	87.5W	200	80	80	5A			20	80	1A			4							3	
2N4904	AP	S	P	87.5W	200	40	40	5A			25	100	2.5A			4							3	
2N4905	AP	S	P	87.5W	200	60	60	5A			25	100	2.5A			4							3	
2N4906	AP	S	P	87.5W	200	80	80	5A			25	100	2.5A			4							3	
2N4913	AP	S	N	87.5W	200	40	40	5A			25	100	2.5A			4							3	
2N4914	AP	S	N	87.5W	200	60	60	5A			25	100	2.5A			4							3	
2N4915	AP	S	N	87.5W	200	80	80	5A			25	100	2.5A			4							3	
2N4996	AH	S	N	250	150	30	18	50	100n	15	50		2										1/17	
2N4997	AH	S	N	250	150	30	18	50	100n	15	30	150	2										1/17	
2N4998	APH	S	N	35W	200	100	80	2A			30	90	1A										59	
2N4999	APH	S	P	35W	200	100	80	2A			30	90	1A										59	
2N5000	APH	S	N	35W	200	100	80	2A			70	200	1A										59	
2N5001	APH	S	P	35W	200	100	80	2A			70	200	1A										59	
2N5002	APH	S	N	57W	200	100	80	5A			30	90	2.5A										59	
2N5003	APH	S	P	57W	200	100	80	5A			30	90	2.5A										59	
2N5004	APH	S	N	57W	200	100	80	5A			70	200	2.5A										59	
2N5005	APH	S	P	57W	200	100	80	5A			70	200	2.5A										59	

TYPE	TOSHIBA	NEC	HITACHI	mitsubishi	MATSUSHITA	FUJITSU	SONY	SANYO	NOTE
A5T4410		2SC1217							
2N4423				2SA696	2SA719				
2N4854									
2N4855									
2N4901	2SA680								
2N4902	2SA680								
2N4903	2SA680								
2N4904	2SA680								
2N4905	2SA680								
2N4906	2SA680								
2N4913	2SC1080		2SC1343						
2N4914	2SC1080		2SC1343						
2N4915	2SC1080		2SC1343						
2N4996	2SC383		2SC684				2SC1128		
2N4997	2SC383		2SC684				2SC1128		
2N4998	2SC558			2SC766	2SC901				
2N4999		2SA648							
2N5000	2SC558			2SC766	2SC901				
2N5001		2SA648							
2N5002	2SC558				2SC901				
2N5003		2SA648							
2N5004	2SC558				2SC901				
2N5005		2SA648							

TYPE	USE	MATERIAL	POLARITY	MAXIMUM RATINGS				ELECTRICAL CHARACTERISTICS														OUTLINE TO.	NOTE				
				Pc 25°C (mW)	Tj (°C)	Vce (V)	Vceo (V)	Ic (mA)	I _{ceo}			hfe	h _{ie} (Ω)	h _{re} (×10 ⁻³)	h _{oe} (μS)	f _T *f _{osc} **f _{osc} (MHz)	NF (dB)	Cob (pF)	Covibr (ps)								
									(μA)	Vce(V)	min.									max.	Ic(mA)						
2N5038	APH	S	N	140W	200	150	90	20A										60							3		
2N5039	APH	S	N	140W	200	120	75	20A										60								3	
2N5058	A	S	N	1W	200	300	300	150	50n	100	30	150	30													39	
A5T5058	A	S	N	800	150	300	300	150	50n	100	30	150	30													39	
2N5059	A	S	N	1W	200	250	250	150	50n	100	30	150	30													39	
A5T5059	A	S	N	800	150	250	250	150	50n	100	30	150	30													39	
2N5067	AP	S	N	87.5W	200	40	40	5A									4									3	
2N5068	AP	S	N	87.5W	200	60	60	5A									4									3	
2N5069	AP	S	N	87.5W	200	80	80	5A									4									3	
2N5086	A	S	P	625	150	50	50	50	50n	35	150	500	0.1				40	3								39	
A5T5086	A	S	P	625	150	50	50	50	50n	35	150	500	0.1				40	3								39	
2N5087	A	S	P	625	150	50	50	50	50n	35	250	800	0.1				40	2								39	
A5T5087	A	S	P	625	150	50	50	50	50n	35	250	800	0.1				40	2								39	
2N5147	APH	S	P	7W	200	100	80	2A																		39	
2N5148	APH	S	N	7W	200	100	80	2A																		39	
2N5149	APH	S	P	7W	200	100	80	2A																		39	
2N5150	APH	S	N	7W	200	100	80	2A																		39	
2N5157	APH	S	N	100W	150		500	3.5A									5									3	
A5T5172	A	S	N	625	150	25	25	100	100n	25	100	500	10													39	
A7T5172	A	S	N	625	150	25	25	100	100n	25	100	500	10													39	
A8T5172	A	S	N	625	150	25	25	100	100n	25	100	500	10													39	
2N5209	A	S	N	625	150	50	50	50	50n	35	100	300	0.1				3									39	
A5T5209	A	S	N	625	150	50	50	50	50n	35	100	300	0.1				3									39	
2N5210	A	S	N	625	150	50	50	50	50n	35	200	600	0.1				2									39	
A5T5210	A	S	N	625	150	50	50	50	50n	35	200	600	0.1				2									39	
2N5219	AH	S	N	625	150	20	15	100	100n	10	35	500	2				150									39	
A5T5219	AH	S	N	625	150	20	15	100	100n	10	35	500	2				150									39	
2N5220	AH	S	N	625	150	15	15	500	100n	10	30	600	50				100									39	
A5T5220	AH	S	N	625	150	15	15	500	100n	10	30	600	50				100									39	
2N5221	AH	S	P	625	150	15	15	500	100n	10	30	600	50				100									39	
A5T5221	AH	S	P	625	150	15	15	500	100n	10	30	600	50				100									39	
2N5222	AH	S	N	625	150	20	15	50	100n	10	20	1500	4				450									39	
A6T5222	AH	S	N	625	150	20	15	50	100n	10	20	1500	4				450									39	
2N5223	AH	S	P	625	150	25	20	100	100n	10	50	800	2				150									39	
A5T5223	AH	S	P	625	150	25	20	100	100n	10	50	800	2				150									39	
2N5225	AH	S	N	625	150	25	25	500	300n	15	30	600	50				50									39	
A5T5225	AH	S	N	625	150	25	25	500	300n	15	30	600	50				50									39	
2N5226	AH	S	P	625	150	25	25	500	300n	15	30	600	50				50									39	
A5T5226	AH	S	P	625	150	25	25	500	300n	15	30	600	50				50									39	
2N5227	AH	S	P	625	150	30	30	50	100n	10	50	700	2				100									39	
A5T5227	AH	S	P	625	150	30	30	50	100n	10	50	700	2				100									39	
2N5241	APH	S	N	125W	150		400	5A									5									3	
2N5301	APH	S	N	200W	200	40	40	30A	1mA	40	15	60	15A				2									3	
2N5302	APH	S	N	200W	200	60	60	30A	1mA	60	15	60	15A				2									3	
2N5303	APH	S	N	200W	200	80	80	20A	1mA	80	15	60	10A				2									3	
2N5332	APH	S	P	360	200	20	12	100	10n	15	20	80	10													46	
2N5333	APH	S	P	15W	200	100	80	2A									30									5	
2N5384	APH	S	P	30W	200	100	80	5A									30									111	
2N5385	APH	S	P	30W	200	100	80	5A									30									111	
2N5386	APH	S	P	50W	200	100	80	12A									30									61	
2N5387	AP	S	N	100W	200	200	200	7.5A									15									61	
2N5388	AP	S	N	100W	200	250	250	7.5A									15									61	
2N5389	AP	S	N	100W	200	300	300	7.5A									15									61	
2N5390	AP	S	N	15W	200	120	80	2A																		33	DARLINGTON
2N5399	AH	S	N	360	200	25	15	100	10n	15	30	90	10													46	

TYPE	TOSHIBA	NEC	HITACHI	MITSUBISHI	MATSUSHITA	FUJITSU	SONY	SANYO	NOTE
2N5038	2SC1435					2SC1301			
2N5039	2SC1435					2SC1301			
2N5058	2SC996								
A5T5058	2SC995	2SC1103A							
2N5059	2SC996								
A5T5059	2SC995	2SC1103A							
2N5067	2SC1080		2SC1343						
2N5068	2SC1080		2SC1343						
2N5069	2SC1080		2SC1343						
2N5086	2SA682								
A5T5086	2SA682								
2N5087	2SA682								
A5T5087	2SA682								
2N5147	2SA740								
2N5148			2SC610		2SC697				
2N5149	2SA740								
2N5150			2SC610		2SC697				
2N5157	2SC1434					2SC1228	2SC1348		
A5T5172	2SC501					2SC971			
A7T5172	2SC501					2SC971			
A8T5172	2SC501					2SC971			
2N5209	2SC501					2SC971			
A5T5209	2SC501					2SC971			
2N5210	2SC501					2SC971			
A5T5210	2SC501					2SC971			
2N5219	2SC501					2SC971			
A5T5219						2SC971			
2N5220	2SC509			2SC1209		2SC971			
A5T5220	2SC509			2SC1209		2SC971			
2N5221		2SA643		2SA695					
A5T5221		2SA643		2SA695					
2N5222	2SC501					2SC971			
A6T5222	2SC501					2SC971			
2N5223									
A5T5223		2SA643							
2N5225	2SC509			2SC1209		2SC971			
A5T5225	2SC509			2SC1209		2SC971			
2N5226		2SA643	2SA537		2SA546				
A5T5226		2SA643	2SA537		2SA546				
2N5227		2SA643							
A5T5227		2SA643							
2N5241	2SC1434					2SC1228			
2N5301	2SC1435					2SC1401			
2N5302	2SC1435					2SC1401			
2N5303	2SC1435					2SC1401			
2N5332			2SA741			2SA524			
2N5333		2SA627							
2N5384		2SA627							
2N5385		2SA627							
2N5386	2SA679								
2N5387	2SC1434								
2N5388	2SC1434								
2N5389	2SC1434								
2N5390	2SD107								
2N5399			2SA741			2SA524			

TYPE	USE	MATERIAL	POLARITY	MAXIMUM RATINGS								ELECTRICAL CHARACTERISTICS											OUTLINE TO.	NOTE
				Pc 25°C (mW)	Tj (°C)	Vas (V)	Vcco (V)	Ic (mA)	I _{iso} (μA)	hfe				hfe (Ω)	hfe (×10)	hoe (μS)	f _T *f _{res} *f _{res} (MHz)	NF (dB)	Cob (pF)	Coxbb (ps)				
										min.	max.	Ic(mA)												
2N5400	A	S	P	625	150	130	120	600	100n	100	40	180	10					100	8				1/2	
A5T5400	A	S	P	625	150	130	120	600	100n	100	40	180	10					100	8				1/2	
2N5401	A	S	P	625	150	160	150	600	50n	120	60	240	10					100	8				1/2	
A5T5401	A	S	P	625	150	160	150	600	50n	120	60	240	10					100	8				1/2	
2N5447	A	S	P	625	150	40	25	200	100n	20	60	300	50					100					1/2	
2N5448	A	S	P	625	150	50	30	200	100n	20	30	150	50					100					1/2	
2N5449	A	S	N	625	150	50	30	800	100n	20	100	300	50					100					1/2	
2N5450	A	S	N	625	150	50	30	800	100n	20	50	150	50					100					1/2	
2N5451	A	S	N	625	150	40	20	800	100n	20	30	600	50					100					1/2	
2N5525	A	S	N	500	150	40	30	200	100n	5													1/2	DARLINGTON
2N5526	A	S	N	500	150	40	30	200	100n	5													1/2	DARLINGTON
2N5550	A	S	N	625	150	160	140	600	100n	100	60	250	10										1/2	
A5T5550	A	S	N	625	150	160	140	600	100n	100	60	250	10										1/2	
2N5551	A	S	N	625	150	180	160	600	50n	120	80	250	10										1/2	
A5T5551	A	S	N	625	150	180	160	600	50n	120	80	250	10										1/2	
2N5571	APH	S	N	140W	200	120	90	30A			20	100	15A					50					3	
2N5572	APH	S	N	140W	200	150	120	30A			20	100	15A					50					3	
2N5683	APH	S	P	300W	200	60	60	50A	2mA	60	15	60	25A					2					3	
2N5684	APH	S	P	300W	200	80	80	50A	2mA	80	15	60	25A					2					3	
2N5685	APH	S	N	300W	200	60	60	50A	2mA	60	15	60	25A					2					3	
2N5686	APH	S	N	300W	200	80	80	50A	2mA	80	15	60	25A					2					3	
2N5758	APH	S	N	150W	200	100	100	6A	1mA	100	25	100	3A					1					3	
2N5759	APH	S	N	150W	200	120	120	6A	1mA	120	20	80	3A					1					3	
2N5760	APH	S	N	150W	200	140	140	6A	1mA	140	15	60	3A					1					3	
2N5867	APH	S	P	87.5W	200	60	60	5A	100	60	20	100	1.5A					4					3	
2N5868	APH	S	P	87.5W	200	80	80	5A	100	80	20	100	1.5A					4					3	
2N5869	APH	S	N	87.5W	200	60	60	5A	100	60	20	100	1.5A					4					3	
2N5870	APH	S	N	87.5W	200	80	80	5A	100	80	20	100	1.5A					4					3	
2N5871	APH	S	P	115W	200	60	60	7A	250	60	20	100	2.5A					4					3	
2N5872	APH	S	P	115W	200	80	80	7A	250	80	20	100	2.5A					4					3	
2N5873	APH	S	N	115W	200	60	60	7A	250	60	20	100	2.5A					4					3	
2N5874	APH	S	N	115W	200	80	80	7A	250	80	20	100	2.5A					4					3	
2N5875	APH	S	P	150W	200	60	60	10A	500	60	20	100	4A					4					3	
2N5876	APH	S	P	150W	200	80	80	10A	500	80	20	100	4A					4					3	
2N5877	APH	S	N	150W	200	60	60	10A	500	60	20	100	4A					4					3	
2N5878	APH	S	N	150W	200	80	80	10A	500	80	20	100	4A					4					3	
2N5879	APH	S	P	160W	200	60	60	15A	500	60	20	100	6A					4					3	
2N5880	APH	S	P	160W	200	80	80	15A	500	80	20	100	6A					4					3	
2N5881	APH	S	N	160W	200	60	60	15A	500	60	20	100	6A					4					3	
2N5882	APH	S	N	160W	200	80	80	15A	500	80	20	100	6A					4					3	
2N5883	APH	S	P	200W	200	60	60	25A	1000	60	20	100	10A					4					3	
2N5884	APH	S	P	200W	200	80	80	25A	1000	80	20	100	10A					4					3	
2N5885	APH	S	N	200W	200	60	60	25A	1000	60	20	100	10A					4					3	
2N5886	APH	S	N	200W	200	80	80	25A	1000	80	20	100	10A					4					3	
2N5938	APH	S	N	20W	200	60	50	3A			30	150	1A					150						
2N5939	APH	S	N	40W	200	80	80	10A			40	200	5A					120					111	
2N5940	APH	S	N	40W	200	70	70	10A			40	200	5A					120					111	
2N6127	APH	S	P	100W	200	100	80	10A			30	120	5A					40					61	
2N6128	APH	S	N	100W	200	100	80	10A			30	120	5A					40					61	
2N6270	APH	S	N	150W	200	100	80	30A			20	100	15A					70					3	
2N6271	APH	S	N	150W	200	120	100	30A			20	100	15A					70					3	
2N6272	APH	S	N	150W	200	100	80	30A			20	100	15A					70					63	
2N6273	APH	S	N	150W	200	120	100	30A			20	100	15A					70					63	
2N6322	AP	S	N	200W	200	300	200	30A			40	150	5A										3	
2N6323	AP	S	N	200W	200	400	300	30A			30	150	5A										3	

TYPE	TOSHIBA	NEC	HITACHI	mitsubishi	MATSUSHITA	FUJITSU	SONY	SANYO	NOTE
2N5400		2SA712							
A5T5400		2SA712							
2N5401		2SA712							
A5T5401		2SA712							
2N5447			2SA537		2SA546				
2N5448			2SA537		2SA546				
2N5449		2SC959	2SC708						
2N5450		2SC959	2SC708						
2N5451		2SC959	2SC708						
2N5525									
2N5526									
2N5550									
A5T5550									
2N5551									
A5T5551									
2N5671	2SC1435					2SC1401			
2N5672	2SC1435					2SC1401			
2N5683									
2N5684									
2N5685									
2N5686									
2N5758	2SC1434		2SC1343						
2N5759	2SC1434		2SC1343						
2N5760	2SC1434								
2N5867	2SA680								
2N5868	2SA680								
2N5869	2SC1080								
2N5870	2SC1080								
2N5871	2SA680								
2N5872	2SA680								
2N5873	2SC1080		2SC1343						
2N5874	2SC1080		2SC1343						
2N5875									
2N5876									
2N5877	2SC1434					2SC1401			
2N5878	2SC1434					2SC1401			
2N5879									
2N5880									
2N5881	2SC1435					2SC1401			
2N5882	2SC1435					2SC1401			
2N5883									
2N5884									
2N5885	2SC1435					2SC1401			
2N5886	2SC1435					2SC1401			
2N5938		2SC1307							
2N5939	2SC1080		2SC1343						
2N5940	2SC1080		2SC1343						
2N6127	2SA679								
2N6128	2SC1080		2SC1343						
2N6270	2SC1435					2SC1299			
2N6271	2SC1435					2SC1299			
2N6272	2SC1435					2SC1299			
2N6273	2SC1435					2SC1299			
2N6322	2SC1435					2SC1299			
2N6323	2SC1435					2SC1299			

TYPE	USE	MATERIAL	POLARITY	MAXIMUM RATINGS				ELECTRICAL CHARACTERISTICS											OUTLINE TO.	NOTE						
				Pc 25°C (mW)	Tj (°C)	Vos (V)	Vceo (V)	Ic (mA)	I _{ceo}			I _{fe}	h _{fe} (β)	h _{re} ($\times 10^{-4}$)	h _{re} ($\times 10^{-3}$)	h _{oe} ($\times 10^{-5}$)	f _r * f _{oss} * f _{12db} (MHz)	NF (dB)			C _{ob} (pF)	C _{ov} bb (ps)				
									(μ A)	V _{os} (V)	min.												max.	I _c (mA)		
2N6324	AP	S	N	200W	200	300	200	30A			40	150	5A										63			
2N6325	AP	S	N	200W	200	400	300	30A			30	150	5A											63		
2N6326	APH	S	N	200W	200	60	60	30A			6	30	30A											3		
2N6327	APH	S	N	200W	200	80	80	30A			6	30	30A											3		
2N6328	APH	S	N	200W	200	100	100	30A			6	30	30A											3		
2N6329	APH	S	P	200W	200	60	60	30A			6	30	30A											3		
2N6330	APH	S	P	200W	200	80	80	30A			6	30	30A											3		
2N6331	APH	S	P	200W	200	100	100	30A			6	30	30A											3		
2N6461	A	S	N	1W	200	300		100	50n	200	30	120	20											39		
2N6462	A	S	N	1W	200	300		100	50n	200	100	300	20											39		
2N6463	A	S	N	1W	200	250		100	50n	150	30	120	20											39		
2N6464	A	S	N	1W	200	250		100	50n	150	100	300	20											39		
TIS37	AH	S	P	625	150	35	32	50	100n	10	45		1			80	2.5								3/2	
TIS38	AH	S	P	625	150	35	32	50	100n	10	25		1			50									3/2	
TIS62A	AH	S	N	500	150	30	12	30	100n	10	30	225	4			500	6								3/2	
TIS63A	AH	S	N	500	150	30	12	30	100n	10	30	225	4			500									3/2	
TIS64A	AH	S	N	500	150	30	12	30	100n	10	50	150	4			500									3/2	
TIS84	AH	S	N	500	150	40	30	50	50n	10	30		4					2.8							3/2	
TIS86	AH	S	N	400	150	30	30	50	100n	15	40	200	4					2.5							3/2	
TIS87	AH	S	N	400	150	45	45	50	100n	15	30	150	12												3/2	
TIS90	A	S	N	625	150	40	40	400	100n	20	160		50												3/2	
TIS90M	A	S	N	625	150	40	40	400	100n	20	160		50												3/2	
TIS91	A	S	P	625	150	40	40	400	100n	20	160		50												3/2	
TIS91M	A	S	P	625	150	40	40	400	100n	20	160		50												3/2	
TIS92	A	S	N	625	150	40	40	400	100n	20	160		50												3/2	
TIS92M	A	S	N	625	150	40	40	400	100n	20	160		50												3/2	
TIS93	A	S	P	625	150	40	40	400	100n	20	160		50												3/2	
TIS93M	A	S	P	625	150	40	40	400	100n	20	160		50												3/2	
TIS94	A	S	N	625	150	60	40	200	10n	40	340		0.1					3							3/2	
TIS95	A	S	N	625	150	80	60	200	10n	40	200		1					3							3/2	
TIS96	A	S	N	625	150	80	65	200	10n	40	110		100					3							3/2	
TIS97	A	S	N	625	150	60	40	200	10n	40	340		0.1					3							3/2	
TIS98	A	S	N	625	150	80	60	200	10n	40	200		1					3							3/2	
TIS99	A	S	N	625	150	80	65	200	10n	40	110		100					3							3/2	
TIS100	A	S	N	625	150	180	180	100	50n	75	20		1												3/2	
TIS101	A	S	N	625	150	150	150	100	50n	75	20		1												3/2	
TIS105	AH	S	N	625	150	45	45	50	50n	30	30	150	10												3/2	
TIS108	AH	S	N	500	150	40	30	50	50n	10	25		4					3							3/2	
TIS109	SW	S	N	625	150	60	30	800	100n	20	100	400	150			250									3/2	
TIS110	SW	S	N	625	150	60	40	800			50	150	150			200									3/2	
TIS111	SW	S	N	625	150	60	40	800			100	300	150			250									3/2	
TIS112	SW	S	P	625	150	60	40	600	20n	50	100	300	150												3/2	
TIS125	AH	S	N	250	150	40	30	50	50n	10	30		4												3/2	
TIS126	AH	S	N	400	150	45	30	50	50n	30	25		10			600									3/2	
TIS128	AH	S	P	250	150	60	45	30	100n	25	30		2												3/2	
TIS129	AH	S	N	250	150	40	25	30	100n	25	60		4			800									3/2	
TIS133	SW	S	N	700	150	50	30	500	1.7	60	60	150	100												3/2	
TIS134	SW	S	N	700	150	50	30	500	1.7	60	50	150	100												3/2	
TIS135	SW	S	N	700	150	80	50	500	1.7	60	60	150	100												3/2	
TIS136	SW	S	N	700	150	80	50	500	1.7	60	50	150	100												3/2	
TIS137	AH	S	P	625	150	35	32	50	100n	10	45		1			80									3/2	
TIS138	AH	S	P	625	150	35	32	50	100n	10	25		1			50									3/2	

TYPE	TOSHIBA	NEC	HITACHI	mitsubishi	MATSUSHITA	FUJITSU	SONY	SANYO	NOTE
2N6324	2SC1435					2SC1299			
2N6325	2SC1435					2SC1401			
2N6326	2SC1435					2SC1299			
2N6327	2SC1435					2SC1299			
2N6328	2SC1435					2SC1299			
2N6329									
2N6330									
2N6331									
2N6461	2SC996		2SC685						
2N6462	2SC996		2SC685						
2N6463	2SC996		2SC685						
2N6464	2SC996		2SC685						
T1S37		2SA682					2SA706		
T1S38		2SA682					2SA706		
T1S62A		2SC729					2SC470		
T1S63A		2SC729					2SC470		
T1S64A		2SC729					2SC470		
T1S84		2SC729					2SC470		
T1S86		2SC729					2SC470		
T1S87		2SC729					2SC470		
T1S90	2SC509					2SC1247			
T1S90M	2SC509					2SC1247			
T1S91		2SA643		2SA696					
T1S91M		2SA643		2SA696					
T1S92	2SC509					2SC1247			
T1S92M	2SC509					2SC1247			
T1S93		2SA643		2SA696					
T1S93M		2SA643		2SA696					
T1S94		2SC959					2SC1124		
T1S95		2SC959					2SC1124		
T1S96		2SC959					2SC1124		
T1S97		2SC959					2SC1124		
T1S98		2SC959					2SC1124		
T1S99							2SC1124		
T1S100	2SC995						2SC1127		
T1S101	2SC995						2SC1127		
T1S105	2SC501					2SC971			
T1S108						2SC971			
T1S109		2SC959					2SC1124		
T1S110		2SC959					2SC1124		
T1S111		2SC959					2SC1124		
T1S112			2SA537		2SA546				
T1S125						2SC829			
T1S126						2SC829			
T1S128			2SA530			2SA558			
T1S129			2SC684				2SC1128		
T1S133		2SC959					2SC1124		
T1S134		2SC959					2SC1124		
T1S135		2SC959					2SC1124		
T1S136		2SC959					2SC1124		
T1S137		2SA682					2SA706		
T1S138		2SA682					2SA706		

TYPE	USE	MATERIAL	POLARITY	MAXIMUM RATINGS						ELECTRICAL CHARACTERISTICS											OUTLINE TO.	NOTE						
				Pc 25°C (mW)	Tj (°C)	Vas (V)	Vceo (V)	Ic (mA)	I _{iso}		hFE		hfe	h _{ie} (Ω)	h _{re} (×10)	h _{oe} (μS)	f _T *f _{max} (MHz)	NF (dB)	C _{ob} (pF)	C _{ox} (ps)								
									(μA)	V _{sat} (V)	min.	max.											Ic(mA)					
T1156	AP	G	P	25W	100	30	30	3A	80	2	25	75	500						0.22					3/27				
T1156L	AP	G	P	25W	100	30	30	3A	80	2	25	75	500						0.22						3/27			
T1159	AP	G	P	20W	100	40	40	3A	125	20	20	60	1A												3/29			
T1160	AP	G	P		100	60	60	3A			30	20	60	1A												3/29		
T1161	AP	G	P		100	80	80	3A			40	20	60	1A													3/29	
T1162	AP	G	P		100	100	100	3A			50	20	60	1A													3/29	
T1486	APH	S	N	15W	200	80	60	1A			20	80	200						50								5	
T1487	APH	S	N	15W	200	80	60	1A			20	80	200						50									
T11131	APH	S	N	80W	175	200	100	7.5A			30	120	2A						7.5									61
T11132	APH	S	N	80W	175	200	100	7.5A			15	60	2A						7.5									61
T11133	APH	S	N	80W	175	150	150	7.5A			30	120	2A						7.5									61
T11134	APH	S	N	80W	175	150	150	7.5A			15	60	2A						7.5									61
T11135	APH	S	N	80W	175	100	50	7.5A			30	120	2A						7.5									61
T11136	APH	S	N	80W	175	100	50	7.5A			15	60	2A						7.5									61
T11151	APH	S	N	80W	175	200	100	7.5A			20	80	5A						7.5									61
T11152	APH	S	N	80W	175	200	100	7.5A			10	40	5A						7.5									61
T11153	APH	S	N	80W	175	150	75	7.5A			20	80	5A						7.5									61
T11154	APH	S	N	80W	175	150	75	7.5A			10	40	5A						7.5									61
T11155	APH	S	N	80W	175	100	50	7.5A			20	80	5A						7.5									61
T11156	APH	S	N	80W	175	100	50	7.5A			10	40	5A						7.5									61
T13027	AP	G	P	106W	100	45		7A	1mA	30	40	250	3A															61
T13028	AP	G	P	106W	100	60		7A	1mA	40	40	250	3A															3
T13029	AP	G	P	106W	100	80		7A	1mA	50	40	250	3A															3
T13030	AP	G	P	106W	100	100		7A	1mA	60	40	250	3A															3
T13031	AP	G	P	106W	100	120		7A	1mA	70	40	250	3A															3
TIP29	APH	S	N	30W	150	40	40	1A			15	75	1A						3									3/19
TIP29A	APH	S	N	30W	150	60	60	1A			15	75	1A						3									3/19
TIP29B	APH	S	N	30W	150	80	80	1A			15	75	1A						3									3/19
TIP29C	APH	S	N	30W	150	100	100	1A			15	75	1A						3									3/19
TIP30	APH	S	P	30W	150	40	40	1A			15	75	1A						3									3/19
TIP30A	APH	S	P	30W	150	60	60	1A			15	75	1A						3									3/19
TIP30B	APH	S	P	30W	150	80	80	1A			15	75	1A						3									3/19
TIP30C	APH	S	P	30W	150	100	100	1A			15	75	1A						3									3/19
TIP31	APH	S	N	40W	150	40	40	3A			10	50	3A						3									3/27
TIP31A	APH	S	N	40W	150	60	60	3A			10	50	3A						3									3/27
TIP31B	APH	S	N	40W	150	80	80	3A			10	50	3A						3									3/27
TIP31C	APH	S	N	40W	150	100	100	3A			10	50	3A						3									3/27
TIP32	APH	S	P	40W	150	40	40	3A			10	50	3A						3									3/27
TIP32A	APH	S	P	40W	150	60	60	3A			10	50	3A						3									3/27
TIP32B	APH	S	P	40W	150	80	80	3A			10	50	3A						3									3/27
TIP32C	APH	S	P	40W	150	100	100	3A			10	50	3A						3									3/27
TIP33	APH	S	N	80W	150	40	40	10A			20	100	3A						3									3/35
TIP33A	APH	S	N	80W	150	60	60	10A			20	100	3A						3									3/35
TIP33B	APH	S	N	80W	150	80	80	10A			20	100	3A						3									3/35
TIP33C	APH	S	N	80W	150	100	100	10A			20	100	3A						3									3/35
TIP34	APH	S	P	80W	150	40	40	10A			20	100	3A						3									3/35
TIP34A	APH	S	P	80W	150	60	60	10A			20	100	3A						3									3/35
TIP34B	APH	S	P	80W	150	80	80	10A			20	100	3A						3									3/35
TIP34C	APH	S	P	80W	150	100	100	10A			20	100	3A						3									3/35
TIP35	APH	S	N	125W	150	40	40	25A			10	50	15A						3									3/43
TIP35A	APH	S	N	125W	150	60	60	25A			10	50	15A						3									3/43
TIP35B	APH	S	N	125W	150	80	80	25A			10	50	15A						3									3/43
TIP35C	APH	S	N	125W	150	100	100	25A			10	50	15A						3									3/43
TIP36	APH	S	P	125W	150	40	40	25A			10	50	15A						3									3/43
TIP36A	APH	S	P	125W	150	60	60	25A			10	50	15A						3									3/43

TYPE	TOSHIBA	NEC	HITACHI	MITSUBISHI	MATSUSHITA	FUJITSU	SONY	SANYO	NOTE
TI156		2SB251	2SB337		2SB449				
TI156L		2SB251	2SB337		2SB449				
TI159		2SB251A	2SB337		2SB449				
TI160		2SB251A	2SB340		2SB449				
TI161		2SB252	2SB340						
TI162		2SB252A	2SB340						
TI486		2SCI161			2SCI398				
TI487		2SCI161			2SCI398				
TI1131	2SCI079					2SCI229	2SC807		
TI1132	2SCI079					2SCI229	2SC807		
TI1133	2SCI079					2SCI229	2SC807		
TI1134	2SCI079					2SCI229	2SC807		
TI1135	2SCI079					2SCI229	2SC807		
TI1136	2SCI079					2SCI229	2SC807		
TI1151	2SCI195					2SCI229	2SC807		
TI1152	2SCI195					2SCI229	2SC807		
TI1153	2SCI079					2SCI229	2SC807		
TI1154	2SCI079					2SCI229	2SC807		
TI1155	2SCI079					2SCI229	2SC807		
TI1156	2SCI079					2SCI229	2SC807		
TI3027		2SA650					2SB520		
TI3028		2SA650					2SB520		
TI3029		2SA650					2SB520		
TI3030		2SA650					2SB520		
TI3031		2SA650					2SB520		
TIP29	2SD103	2SD217			2SD226B				
TIP29A	2SD103	2SD217							
TIP29B	2SD102	2SD217							
TIP29C	2SD102	2SD217							
TIP30	2SB503	2SB506							
TIP30A	2SB503	2SB506							
TIP30B	2SB502	2SB506							
TIP30C	2SB502	2SB506							
TIP31	2SD111						2SD316		
TIP31A	2SD111						2SD316		
TIP31B	2SD111						2SD316		
TIP31C	2SD111						2SD316		
TIP32	2SA679						2SB518		
TIP32A	2SA679						2SB518		
TIP32B	2SA679						2SB518		
TIP32C	2SA679						2SB518		
TIP33			2SC1343			2SCI229			
TIP33A			2SC1343			2SCI229			
TIP33B			2SC1343			2SCI229			
TIP33C			2SC1343			2SCI229			
TIP34	2SA679						2SB519		
TIP34A	2SA679						2SB519		
TIP34B	2SA679						2SB519		
TIP34C	2SA679						2SB519		
TIP35	2SD114					2SD250			
TIP35A	2SD114					2SD250			
TIP35B	2SD113					2SD250			
TIP35C	2SD113					2SD250			
TIP36									
TIP36A									

TYPE	USE	MATERIAL	POLARITY	MAXIMUM RATINGS				ELECTRICAL CHARACTERISTICS										OUTLINE ID.	NOTE				
				Pc 25°C (mW)	Tj (°C)	V _{ce} (V)	V _{ceo} (V)	I _c (mA)	I _{ceo}		h _{FE}		h _{FE} (Ω)	h _{FE} (×10)	h _{FE} (μs)	f _T *† (MHz)	NF (dB)			C _{ob} (pF)	C _{cor} (ps)		
									(μA)	V _{ce} (V)	min.	max.										I _c (mA)	
TIP36B	APP	S	P	125W	150	80	80	25A											3	5/32			
TIP36C	APP	S	P	125W	150	100	100	25A												3	5/32		
TIP41	APP	S	N	65W	150	40	40	6A				15	75	3A						3	5/31		
TIP41A	AHP	S	N	65W	150	60	60	6A				15	75	3A						3	5/31		
TIP41B	AHP	S	N	65W	150	80	80	6A				15	75	3A						3	5/31		
TIP41C	APH	S	N	65W	150	100	100	6A				15	75	3A						3	5/31		
TIP42	APH	S	P	65W	150	40	40	6A				15	75	3A						3	5/31		
TIP42A	APH	S	P	65W	150	60	60	6A				15	75	3A						3	5/31		
TIP42B	APH	S	P	65W	150	80	80	6A				15	75	3A						3	5/31		
TIP42C	APH	S	P	65W	150	100	100	6A				15	75	3A						3	5/31		
TIP47	AP	S	N	40W	150	350	250	1A				30	150	300						10	5/39		
TIP48	AP	S	N	40W	150	400	300	1A				30	150	300						10	5/39		
TIP49	AP	S	N	40W	150	450	350	1A				30	150	300						10	5/39		
TIP50	AP	S	N	40W	150	500	400	1A				30	150	300						10	5/39		
TIP51	AP	S	N	100W	150	350	250	3A				30	150	300						2.5	5/33		
TIP52	AP	S	N	100W	150	400	300	3A				30	150	300						2.5	5/33		
TIP53	AP	S	N	100W	150	450	350	3A				30	150	300						2.5	5/33		
TIP54	AP	S	N	100W	150	500	400	3A				30	150	300						2.5	5/33		
TIP110	AP	S	N	50W	150	60	60	2A	1mA	60	1000			1A							5/37	DARLINGTON	
TIP111	AP	S	N	50W	150	80	80	2A	1mA	80	1000			1A								5/37	DARLINGTON
TIP112	AP	S	N	50W	150	100	100	2A	1mA	100	1000			1A								5/37	DARLINGTON
TIP115	AP	S	P	50W	150	60	60	2A	1mA	60	1000			1A								5/37	DARLINGTON
TIP116	AP	S	P	50W	150	80	80	2A	1mA	80	1000			1A								5/37	DARLINGTON
TIP117	AP	S	P	50W	150	100	100	2A	1mA	100	1000			1A								5/37	DARLINGTON
TIP120	AP	S	N	65W	150	60	60	5A	200	60	1000			3A								5/75	DARLINGTON
TIP121	AP	S	N	65W	150	80	80	5A	200	80	1000			3A								5/75	DARLINGTON
TIP122	AP	S	N	65W	150	100	100	5A	200	100	1000			3A								5/75	DARLINGTON
TIP125	AP	S	P	65W	150	60	60	5A	200	60	1000			3A								5/75	DARLINGTON
TIP126	AP	S	P	65W	150	80	80	5A	200	80	1000			3A								5/75	DARLINGTON
TIP127	AP	S	P	65W	150	100	100	5A	200	100	1000			3A								5/75	DARLINGTON
TIP140	AP	S	N	125W	150	60	60	10A	1mA	60	1000			5A								5/33	DARLINGTON
TIP141	AP	S	N	125W	150	80	80	10A	1mA	80	1000			5A								5/33	DARLINGTON
TIP142	AP	S	N	125W	150	100	100	10A	1mA	100	1000			5A								5/33	DARLINGTON
TIP145	AP	S	P	125W	150	60	60	10A	1mA	60	1000			5A								5/33	DARLINGTON
TIP146	AP	S	P	125W	150	80	80	10A	1mA	80	1000			5A								5/33	DARLINGTON
TIP147	AP	S	P	125W	150	100	100	10A	1mA	100	1000			5A								5/33	DARLINGTON
TIP501	APH	S	N	6W	200	40	40	3A	10	40	25	180	1A							60		39	
TIP502	APH	S	N	6W	200	60	60	3A	10	60	25	180	1A							60		39	
TIP503	APH	S	N	20W	200	130	120	2A			40	200	1A							70		66	
TIP504	APH	S	N	20W	200	160	150	2A			40	200	1A							70		66	
TIP505	APH	S	N	20W	200	130	120	2A			40	200	1A							70		59	
TIP506	APH	S	N	20W	200	160	150	2A			40	200	1A							70		59	
TIP507	APH	S	P	20W	200	150	150	2A			30	120	1A							50		59	
TIP508	APH	S	P	4W	200	150	150	2A			30	120	1A							50		39	
TIP509	APH	S	N	30W	200	130	120	4A			40	200	2A							70		3	
TIP510	APH	S	N	30W	200	160	150	4A			40	200	2A							70		3	
TIP511	APH	S	N	30W	200	130	120	4A			40	200	2A							70		61	
TIP512	APH	S	N	30W	200	160	150	4A			40	200	2A							70		61	
TIP513	APH	S	P	30W	200	150	150	5A			30	150	2.5A							40		59	
TIP514	APH	S	P	20W	200	150	150	5A			30	150	2.5A							40		66	
TIP515	APH	S	N	80W	200	130	120	12A			40	200	6A							70		3	
TIP516	APH	S	N	80W	200	160	150	12A			40	200	6A							70		3	
TIP517	APH	S	N	80W	200	130	120	12A			40	200	6A							70		61	
TIP518	APH	S	N	80W	200	160	150	12A			40	200	6A							70		61	
TIP519	APH	S	P	50W	200	150	150	8A			30	150	4A							40		3	

TYPE	TOSHIBA	NEC	HITACHI	MITSUBISHI	MATSUSHITA	FUJITSU	SONY	SANYO	NOTE
TIP36B									
TIP36C									
TIP41	2SC793		2SC681						
TIP41A	2SC793		2SC681						
TIP41B	2SC793		2SC681						
TIP41C	2SC793		2SC681						
TIP42	2SA658	2SA627							
TIP42A	2SA658	2SA627							
TIP42B	2SA657	2SA627							
TIP42C	2SA657	2SA627							
TIP47	2SC1005						2SC1348		
TIP48	2SC1005						2SC1348		
TIP49	2SC1005						2SC1348		
TIP50	2SC1005						2SC1348		
TIP51							2SC1348		
TIP52							2SC1348		
TIP53							2SC1348		
TIP54							2SC1348		
TIP110	2SD107						2SD88		
TIP111	2SD107						2SD88		
TIP112	2SD111						2SD88		
TIP115	2SB530	2SB506							
TIP116	2SB530	2SB506							
TIP117	2SB530	2SB506							
TIP120	2SD111						2SD88		
TIP121	2SD111						2SD88		
TIP122	2SD111						2SD88		
TIP125	2SB530	2SB506					2SB519		
TIP126	2SB530	2SB506					2SB519		
TIP127	2SB530	2SB506					2SB519		
TIP140	2SD113					2SD196			
TIP141	2SD113					2SD196			
TIP142	2SD113					2SD196			
TIP145							2SB520		
TIP146							2SB520		
TIP147							2SB520		
TIP501		2SC1306	2SC1061		2SC697				
TIP502		2SC1306	2SC1061		2SC697				
TIP503				2SC767	2SC840A				
TIP504				2SC767	2SC840A				
TIP505				2SC767	2SC840A				
TIP506				2SC767	2SC840A				
TIP507		2SA649							
TIP508									
TIP509	2SC1433		2SC681						
TIP510	2SC1433		2SC681						
TIP511	2SC1433		2SC681						
TIP512	2SC1433		2SC681						
TIP513	2SA656								
TIP514	2SA656								
TIP515	2SC1079		2SC1343						
TIP516	2SC1079		2SC1343						
TIP517	2SC1079		2SC1343						
TIP518	2SC1079		2SC1343						
TIP519	2SA656								

TYPE	USE	MATERIAL	POLARITY	MAXIMUM RATINGS					ELECTRICAL CHARACTERISTICS											OUTLINE TO.	NOTE			
				Pc 25°C (mW)	Tj (°C)	Vce (V)	Vceo (V)	Ic (mA)	I _{ceo} (μA)	V _{ce} (V)	h _{FE}		h _{FE}	h _{ie} (Ω)	h _{re} (×10)	h _{oe} (μS)	f _T *f _{oe} **f _{ob} (MHz)	NF (dB)	C _{ob} (pF)			C _{os} (ps)		
TIP520	APH	S	P	50W	200	150	150	8A			30	150	4A				40						61	
TIP521	APH	S	P	20W	200	200	200	2A			20	100	1A				50						59	
TIP522	APH	S	P	4W	200	200	200	2A			20	100	1A				50						39	
TIP523	APH	S	P	30W	200	200	200	5A			20	100	2.5A				40						59	
TIP524	APH	S	P	6W	200	200	200	5A			20	100	2.5A				40						39	
TIP525	APH	S	N	60W	200	250	200	5A			30	150	2.5A				40						3	
TIP526	APH	S	N	60W	200	250	200	5A			30	150	2.5A				40						61	
TIP527	APH	S	P	60W	200	200	200	8A			20	100	4A				40						3	
TIP528	APH	S	P	60W	200	200	200	8A			20	100	4A				40						61	
TIP529	APH	S	N	67W	200	400	300	3A			25	125	1.5A				20						61	
TIP530	APH	S	N	20W	200	400	300	3A			25	125	1.5A				20						66	
TIP531	APH	S	N	150W	175	340	300	15A			20	120	7.5A				50						3	
TIP532	APH	S	N	150W	175	450	400	15A			20	120	7.5A				50						3	
TIP533	APH	S	N	150W	175	340	300	15A			20	120	7.5A				50						63	
TIP534	APH	S	N	150W	175	450	400	15A			20	120	7.5A				50						63	
TIP535	APH	S	N	100W	200	300	200	7.5A			20	100	5A				10						3	
TIP536	APH	S	N	100W	200	400	300	7.5A			20	100	5A				10						3	
TIP537	APH	S	N	100W	200	500	400	7.5A			20	100	5A				10						3	
TIP538	APH	S	N	125W	200	300	200	15A			20	100	7.5A				10						3	
TIP539	APH	S	N	125W	200	400	300	15A			20	100	7.5A				10						3	
TIP540	APH	S	N	125W	200	500	400	15A			20	100	7.5A				10						3	
TIP541	APH	S	N	4W	200	50	45	2A			40	200	1A				150						39	
TIP542	APH	S	N	40W	200	50	45	10A			40	200	5A				150						59	
TIP543	APH	S	N	40W	200	75	65	10A			40	200	5A				120						59	
TIP544	APH	S	P	150W	200	100	100	6A	1mA	100	25	100	3A				1						3	
TIP545	APH	S	P	150W	200	120	120	6A	1mA	120	20	80	3A				1						3	
TIP546	APH	S	P	150W	200	140	140	6A	1mA	140	15	60	3A				1						3	
TIP640	AP	S	N	175W	200	60	60	10A	1mA	60	1000	5A											3	DARLINGTON
TIP641	AP	S	N	175W	200	80	80	10A	1mA	80	1000	5A											3	DARLINGTON
TIP642	AP	S	N	175W	200	100	100	10A	1mA	100	1000	5A											3	DARLINGTON
TIP645	AP	S	P	175W	200	60	60	10A	1mA	60	1000	5A											3	DARLINGTON
TIP646	AP	S	P	175W	200	80	80	10A	1mA	80	1000	5A											3	DARLINGTON
TIP647	AP	S	P	175W	200	100	100	10A	1mA	100	1000	5A											3	DARLINGTON
TIP2955	APH	S	P	90W	150	100	70	15A			20	70	4A										5/41	
TIP3055		S	N	90W	150	100	70	15A			20	70	4A										5/41	

TYPE	TOSHIBA	NEC	HITACHI	MITSUBISHI	MATSUSHITA	FUJITSU	SONY	SANYO	NOTE
TIP520	2SA656								
TIP521	2SC739								
TIP522									
TIP523									
TIP524									
TIP525	2SC558				2SC901A				
TIP526	2SC558				2SC901A				
TIP527									
TIP528									
TIP529	2SC1005	2SC1100					2SC1086		
TIP530	2SC1005	2SC1100							
TIP531	2SC1434					2SC1300			
TIP532	2SC1434					2SC1300			
TIP533	2SC1434					2SC1300			
TIP534	2SC1434					2SC1300			
TIP535							2SC807		
TIP536							2SC807		
TIP537							2SC807		
TIP538	2SC1434								
TIP539	2SC1434								
TIP540	2SC1434								
TIP541	2SC549	2SC799		2SC1239		2SC866			
TIP542				2SC889					
TIP543				2SC889					
TIP544									
TIP545									
TIP546									
TIP640						2SC1301			
TIP641						2SC1301			
TIP642						2SC1301			
TIP645									
TIP646									
TIP647									
TIP2955	2SA679						2SB520		
TIP3055	2SC1079					2SC1301			

MOTOROLA

MOTOROLA

TYPE	USE	MATERIAL	POLARITY	MAXIMUM RATINGS								ELECTRICAL CHARACTERISTICS											OUTLINE TO:	NOTE	
				Pc 25°C (mW)	Tj (°C)	Vas (V)	Vas (V)	Ic (mA)	I _{CEO}		hfe		hfe	hie (Ω)	hre (x10)	hoe (μS)	fT fT #f ₀ #f ₁₀₀ (MHz)	NF (dB)	Cob (pF)	Cstrb (ps)					
									(μA)	Vce(V)	min.	max.									Ic(mA)				
2N174	SP	G	P	100W	95	80	70	15A	2 mA	80	25	50	5	A					10K*			36			
2N176	AH	G	P	90W	80	40	30	3 A	5 A	50	2	25		500	45	7			7K*				3		
2N178	A	G	P	40W	90	30	30	3 A	5 A	50	2	15	45	500	30	8			5K*				3		
2N242	A	G	P	20W	85	45	45	5 A	5 mA	1	30	120		500					5K*				3		
2N277	AP	G	P	70W	95	40	40	15A	100	2	35	70	5	A					10K*				36		
2N297A	AP	G	P	35W	95	60	50	5 A	3 mA	60	40	100		500					5K*				3		
2N319	A	G	P	225	85	25	20	500	16	25	23	42		20					1**				35	5	
2N322	A	G	P	140	60	18	18	500	16	16	34	65		20					1**				35	5	
2N331	A	G	P	200	71	30			10	30	30	70		1	30					1KHz 20			50	5	
2N350A	AP	G	P	90W	100	50	40		50	2	20	60		700	30	5			5K*					3	
2N375	AP	G	P	58W	95	80	60	3 A	3 mA	60	35	90	1	A					5K*					3	
2N378	SP	G	P	50W	100	20		5 A	500	25	40	80	2	A					5K*					3	
2N381	A	G	P	200	100	50	25	400	6	25	35	65		20	35	300	6.6	420	3**	1KHz 5			20	5	
2N398	SP	G	P	50	55	105	105	100	12	105	20			5					1**					5	
2N404	S	G	P	150	85	25		150	0.8	12	30			12	135	3.6K	8	50					8	5	
2N441	AP	G	P	150W	95	40	40	10A	2 nA	40	20	40	5	A					10K*					36	
2N456A	AP	G	P	150W		40	40	7 A	500	20	30	90	5	A					0.2					3	
2N460	A	G	P	200	100	45		400	15	45	16	32			17				1.2**	1KHz 20			20	5	
2N464	A	G	P	150	85	45	40	500	6	20					14	900				1KHz 22				5	
2N499	AH	G	P	30	85	30	18	50	10	15				20					120	200MHz 7.5			2.5	5	1
2N508A	A	G	P	100	30	30		200	7	25	100	200	20		75				2.5**	1KHz 5			35	5	
2N524	A	G	P	225	100	45	30	500	10	30	25	42	20		18				0.8**	1KHz 15			5	5	
2N559	A	G	P	150	100	15	15	50	5	5	25	150	10						300				6	18	
2N650	A	G	P	200	100	45	30	500	3	30	30			10	30				1.5**	1KHz 5			10	5	
2N653	A	G	P	200	100	30	25	250	5	25	20			10	30	750			1.5**	1KHz 10			10	5	
2N656	A	S	N	4 W	200	60	60		10	30	30	90	200			500								5	
2N665	SP	G	P	35W	95	80	40	3 A	50	2	40	80	500						20K*					3	
2N696	S	S	N	600	175	60	40		1	30	20	60	150						40					35	5
2N699	S	S	N	600	175	120	80		2	60	40	120	150		35				50					20	39
2N700	AH	G	P	75	100	25	20	50	0.4	6	1.5		2	4						70MHz 6			1.1		17
2N702	SH	S	N	300	175	25	25	50	0.5	10	20	60	10						70				3	18	
2N705	SH	G	P	300	100	15	15	50	0.2	5	25		10		9				300**				5	18	
2N706	SH	S	N	300	175	25	20		0.005	15	20		10	2					400.				4.5	18	
2N707	AHP	S	N	300	175	56	28		0.005	15	9		10						350				4	80	18
2N708	SH	S	N	360	200	40	20		0.005	20	30	120	10						450				3		18
2N711	SH	G	P	150	100	12	12	50	0.2	5	20	250	10	1.5									6		18
2N718	AH	S	N	400	175	60	40		0.001	30	40	120	150	15									5		18
2N718A	AH	S	N	400	175	60	40		0.001	60	40	120	150	30					300	1KHz 12			4		18
2N720	AH	S	N	400	175	120	80		10 nA	90	40	120	150	100					50				15		18
2N721	AH	S	P	400	200	50	50		1	30	20	45	150	50					50				45		18
2N722	AH	S	P	400	175	50	50	500	1	30	30	40	150	25					60				45		18
2N726	A	S	P	300	175	25	20	50	1	25	15	45	10	90					140				5		18
2N731	A	S	N	500	175	60	40	1 A	1	30	40	120	150						25				35		18
2N735	A	S	N	500	175	80	60	1 A	1	40	30	100	5	100	1.5K								10		18
2N741	AH	G	P	150	100	15	15	100	0.2	6	10		5	20					360	30MHz 7			6		18
2N743	SH	S	N	300	200	20	12	200	1	20	20	60	10						282				5		18
2N744	SH	S	N	300	175	20	12	200			40	120	10	4.5											18
2N827	SH	G	P	150	100	20	20	100	0.5	15	100		10	3.5									4		18
2N828	SH	G	P	150	100	15	15	200	0.4	6	25		10	4					400				3.5		18
2N828A	SH	G	P	150	100	15	15	200	4	6	25		10	4					400				2.2		18
2N834	SH	S	N	300	175	40	30	200	0.5	20	25		10						350				4		18
2N838	SH	G	P	150	100	30	30	100	1	15	30		10	4.5									2		18
2N840	AH	S	N	300	175	45	45	1 A	1	45	30	100	10	90	500		1.2	1.5					15		18
2N869	AH	S	P	360	200	25	18		0.01	15	20	120	10	3									3		18
2N869A	S	S	P	360	200	18	18	200	2.5	15	40	120	30						400				6		18

TYPE	TOSHIBA	NEC	HITACHI	MITSUBISHI	MATSUSHITA	FUJITSU	SONY	SANYO	NOTE
2N174							2SB520		
2N176									
2N178			2SB340		2SB126	2SB151			
2N242	2SB465							2SB342	
2N277							2SB520		
2N297A	2SB366	2SB252	2SB442		2SB310				
2N319	2SB461	2SB326	2SB370A	2SB451		2SB427			
2N322	2SB364		2SB156A	2SB457	2SB370				
2N331									
2N350A									
2N375									
2N378	2SB531	2SB246	2SB337		2SB232	2SB318			
2N381	2SA128								
2N398									
2N404	2SB439			2SB136					
2N441			2SB337						
2N456A									
2N460		2SB224							
2N464									
2N499									
2N508A	2SB51								
2N524		2SB224				2SB427			
2N559		2SA405			2SA774A				
2N650		2SB224				2SB427			
2N653					2SB280		2SB53		
2N656			2SD120						
2N665									
2N696	2SC1166	2SC729				2SC218			
2N699	2SC500					2SC88		2SC66	
2N700						2SA139			
2N702	2SC394	2SC925	2SC717			2SC724	2SC1126		
2N705									
2N706		2SC1044			2SC583				
2N707		2SC1044			2SC583				
2N708									
2N711	2SA75	2SA167							
2N718									
2N718A									
2N720									
2N721	2SA594				2SA720	2SA580			
2N722	2SA594				2SA720	2SA580			
2N726									
2N731	2SC486	2SC959			2SC696			2SC873	
2N735	2SC485	2SC959			2SC696			2SC873	
2N741			2SA211						
2N743	2SC395A	2SC639	2SC689H		2SC456	2SC554			
2N744	2SC395A	2SC639	2SC689H		2SC456				
2N827		2SA206				2SA556			
2N828	2SA65	2SA206				2SA556			
2N828A	2SA65	2SA206				2SA556			
2N834		2SC1216	2SC321H	2SC733		2SC131			
2N838						2SA558			
2N840									
2N869									
2N869A									

MOTOROLA

TYPE	USE	MATERIAL	POLARITY	MAXIMUM RATINGS												ELECTRICAL CHARACTERISTICS													OUTLINE TO:	NOTE
				Pc	Tj	Vce	Vceo	Ic	Iao		hfe		hfe	hie	hre	hoe	ft	NF	Cob	Coxtrb										
				25°C (mW)	(°C)	(V)	(V)	(mA)	(μ A)	Var(V)	min.	max.	ic(mA)	(Ω)	($\times 10$)	(μ S)	**fTg (MHz)	(dB)	(pF)	(ps)										
2N910	A	S	N	500	200	100	80		25 nA	75	75		10			1.8 K	100	60	1 KHz 12	15			18							
2N914	SH	S	N	360	200	40	20	150	0.025	20	30	120	10					300			6			18						
2N915	AH	S	N	360	200	70	50		10 nA	60	50	200	10		2.5	6 K	75				3.5			18						
2N916	AH	S	N	360	200	45	25		10	30	50	200	10		200	6 K	75				6			18						
2N918	AH	S	N	200	200	30	15	50	10 nA	15	20		3						60 MHz 5	1.7	25			72						
2N929	A	S	N	600	175	45	45	30	10 nA	45	40	120	10 μ A	350				30	100K 4		8			18						
2N960	SH	G	P	150	100	15	15		6	20	10							460			2.2			18						
2N963	SH	G	P	150	100	12	12		5	6	20							300			5			18						
2N964A	SH	G	P	150	100	15	15		0.4	6	40		10	4.6				460			2.7			18						
2N968	SH	G	P	150	100	15	15		3	6	17		10					320			4			18						
2N978	AH	S	P	330	150	30	20	600	5	10	15	60	150	2							45			18						
2N985	SH	G	P	150	100	15	7	200	3	5	40		10								6			18						
2N996	AH	S	P	360	200	15	12	200	5 nA	10	35		20						100		10			18						
2N998	AL	S	N	500	200	100	60	500	0.01	90				1000					1 KHz 5		30			72	DARLINGTON					
2N1008	A	G	P	300	85	20	15	300	5	10				40	200									5						
2N1011	AP	G	P	35W	95	80	80	5 A	200	2	30	75	3 A					5 K*						3						
2N1021	AP	G	P	50W	95	100	100	5 A	500	50	23	70	1 A			28		0.2						3						
2N1038	AP	G	P	20W	95	40	40	3 A	125	20	20	60	1 A	72										C180						
2N1042	AP	G	P	20W	100	40	40	3.5A	125	20	20	60	3 A	100										C184						
2N1073	AP	G	P		110	40	40	10A	1 mA	25	20	60	5 A	15										41						
2N1120	AP	G	P	45W	95	80	70	15A	20mA	30	20	50	10A					3 K*						41						
2N1131	S	S	P	600	175	50	35	600	1	30	20	45	150	15										5						
2N1141	AH	G	P	750	100	35		100	0.5	15	10		10	18				1000	4.5 MHz 3		23			5						
2N1162	SP	G	P	90W	100	50	35		125	2	15	65	25					4 K*						3						
2N1185	A	G	P	200	100	45	30	500	3	30	130	170	10	260					1 KHz 5					5						
2N1189	A	G	P	200	100	45	30	500	3	30	60		10					3.5**	1 KHz 5					5						
2N1191	A	G	P	200	100	40	25	200	15	25	20	80	10	40				1.5**	1 KHz 10		20			5						
2N1204	SH	G	P	200	100	20	15	500	0.4	12	15		400	2							3.5			5						
2N1408	S	G	P	150	100	50	50	200	7	5	10			10										5						
2N1412	SP	G	P	70W	95	100	65	15A	200	2	25	50	5 A					5 K*						36						
2N1413	S	G	P	200	85	35	25	500	12	30	25	42	20	20				0.8**						5						
2N1529	AP	G	P	90W	100	40	30	5 A	0.2	2	20	40	3 A											3						
2N1539	AP	G	P	90W	100	40	30	5 A	0.2	2	50	100	3 A					4 K*						3						
2N1549	AP	G	P	90W	100	40	30	15A	0.2	2	10	30	10A					1 K*						3						
2N1561	AH	G	P	250	100	25	15	250	15	10				10				500			7			107						
2N1651	AP	G	P	100W	110	60	60	25A	200	2	35	140	10A	20										41						
2N1705	A	G	P	200	100	18	12	400	5	10				110		6.9		3**	1 KHz 5		20			5						
2N1708	SH	S	N	175	25	12	200	0.025	15	20		10						200			6			46						
2N1724	AP	S	N	50W	175	120	80	5 A	100	3	20	90	2A	1.6							260			6						
2N1751	AP	G	P	106	110	80	80	25A	200	2	30	90	20A	20				1.5**						3						
2N1893	AH	S	N	800	200	120	100	500	0.01	90	40	120	150	30				50			15			5						
2N1924	A	G	P	225	100	60	40	500	10	45	34	65	20	30	700	2	15				30			5						
2N1959	SH	S	N	600	175	60	40	500	0.5	30	40	120	150					100			18			5						
2N1970	AP	G	P	150W	100	100	50	15A	4 mA	100	17	40	5 A					5 K*						36						
2N1983	A	S	N	600	150	50	25	1 A	5	30				70	2 K			40			45			5						
2N1990	SP	S	N	600	150	100		1 A			20		30											39						
2N2042	A	G	P	200	100	105	105	200	25	105	20	50	5	20				0.5**			25			5						
2N2060	A	S	N	500	200	100	80	500	0.002	80	50	150	10	50	1000		4	50	1 KHz 8		15			C32C	DUAL N.N					
2N2075	AP	G	P	170W	110	80	80	15A	0.2	2	20	40	5 A					5 K*						36						
2N2137	AP	G	P	62.5W	100	30	30		0.018	2	30	60	500					20K*						3						
2N2152	AP	G	P	170W	110	45	45	30A	0.08	2	50	100	5 A					2.7K*						36						
2N2192	SH	S	N	800	200	60	40	1 A	0.01	30	100	300	150	2.5							20			5						
2N2212	AHP	G	P	100W	110	120	120	10A	200	2	50	120	5 A	15										4						
2N2218	SH	S	N	800	175	60	30	800	0.01	50	40	120	150	30	1 K	5	3	250	1 KHz 4		8	150		5						
2N2224	SH	S	N	800	175	65	40	500	0.01	50	35	115	10					250			8			5						

TYPE	TOSHIBA	NEC	HITACHI	mitsubishi	MATSUSHITA	FUJITSU	SONY	SANYO	NOTE
2N910	2SC 485	2SC 959			2SC 696				
2N914									
2N915									
2N916	2SC 495	2SC 881		2SC 1210	2SC 696				
2N918	2SC 372	2SC 900	2SC 458	2SC 1312	2SC 644				
2N929		2SC 1217	2SC 154C						
2N960		2SA 405			2SA 774				
2N963		2SA 405			2SA 774				
2N964A		2SA 405			2SA 774				
2N968		2SA 405			2SA 774				
2N978									
2N985		2SA 406			2SA 415				
2N996									
2N998									
2N1008	2SB 364	2SB 327	2SB 496					2SB 408	
2N1011		2SB 252A	2SB 361		2SB 282	2SB 151		2SB 406	
2N1021			2SB 362					2SB 410	
2N1038					2SB 513			2SB 507	
2N1042					2SB 513			2SB 507	
2N1073									
2N1120			2SB334	2SB 479				2SB 410	
2N1131	2SA 505		2SA673A	2SA 697	2SA 731				
2N1141	2SA 509	2SA 707		2SA 696					
2N1162									
2N1185		2SB 226			2SB 324				
2N1189		2SB 226			2SB 324				
2N1191		2SB 226			2SB 324				
2N1204	2SA 562	2SA 723	2SA673	2SA 695					
2N1408	2SB 292A		2SB 77A						
2N1412									
2N1413		2SB 226	2SB370AH		2SB 324	2SB 427			
2N1529									
2N1539									
2N1549									
2N1561							2SA 704		
2N1651									
2N1705	2SA 562	2SA 723	2SA 673	2SA 695	2SA 720				
2N1708	2SC 991	2SC 319		2SC 730	2SC 821				
2N1724	2SD 110		2SD126		2SD 189A	2SD 175	2SD 88		
2N1751									
2N1893		2SC 590							
2N1924	2SA 497	2SA 606		2SA 697	2SA 546				
2N1959	2SC 1382						2SC1124		
2N1970	2SA 679								
2N1983	2SC 1382	2SC 959			2SC 1384				
2N1990	2SC 1382	2SC 959							
2N2042									
2N2060									
2N2075							2SB520		
2N2137	2SA 679								
2N2152									
2N2192	2SC 495	2SC 959						サンケン	
2N2212	2SA 679	2SA 650						2SA747	
2N2218	2SC 495	2SC 959							
2N2224	2SC 495	2SC 959							

MOTOROLA

TYPE	USE	MATERIAL	POLARITY	MAXIMUM RATINGS				ELECTRICAL CHARACTERISTICS													OUTLINE TO:	NOTE		
				Pc 25°C (mW)	Tj (°C)	Vas (V)	Vaos (V)	Ic (mA)	Iao (μA)	Vao(V)	min	hrc max	Ic(mA)	hfe	hie (Ω)	hrc (x10)	hoe (μΩ)	fT * fβe ** fao (MHz)	NF (dB)	Cob (pF)			CoTrb (ps)	
2N2242	SH	S	N	360	200	40	15	225	0.1	20	40	120	10					250		6		18		
2N2256	SH	S	N	300	175	7	7	100	3	6	17		10					320		4		18		
2N2273	AH	G	P	100	100	25	15	100	10	12	20	150	1	20					3.5			18		
2N2288	AP	G	P	60W	110	40	40	10A	200	2	20	60	5	A	25							3		
2N2291	AP	G	P	60W	110	40	30	10A	200	2	50	120	5	A	50							3		
2N2330	SC	S	N	800	150	30	20	500	1 nA	4.5	50		10				100		10			5		
2N2357	SP	G	P	170W	110	60	30	50A	200	2	30	90	20	A	20							41		
2N2368	SH	S	N	360	200	40	40		0.4	20	20	60	10				400		4			18		
2N2369	SH	S	N	360	200	40	40		0.4	20	40	120	10	5								18		
2N2369A	SH	S	N	360	200	40	40	200	30	20		120	10									18		
2N2381	SH	G	P	300	100	30	15	500	1	5	40		200				300		3.5			5		
2N2410	SH	S	N	800	200	60	30	800	0.3	30	30	120	10				200		11			5		
2N2411	SH	S	P	300	200	25	20	200	10 nA	3	25	20	60	10			140		5			18		
2N2415	AH	G	P	75	100	15	10	20	1	10	10	200	2	15			500	200 MHz	0.9	8		72		
2N2453	AM	S	N	500	200	60	30	50	0.005	50	150	600	1	150	5 K	6	5	60		8		C32C	DUAL N.N	
2N2476	SH	S	N	2 W	200	60	20		0.2	30	20		150				250		10			5		
2N2481	SH	S	N	1.2W	200	40	15					40	120	10	3	60			5			18		
2N2490	SP	G	P	170W	110	70	60	15A	3 mA	40	20	40	5	A								36		
2N2501	SH	S	N	360	200	40	20					50	150	10	3.5							18		
2N2526	SHP	G	P	85W	110	80	80	10A	3 mA	80	20	50	3	A	10			350		4		3		
2N2537	SH	S	N	800	200	60	30		0.25	40	50	150	150	2.5						8		5		
2N2604	AH	S	P	400	200	60	45	30	10 nA	45	40		10 μA	60	200		30	10KHz	6			46		
2N2635	SH	G	P	150	100	30	12	100	1	25	45	30	50						2.5			18		
2N2639	AM	S	N	300	200	45	45	30	0.01	45	50	300	10 μA	65			35	10KHz	8			C32C	DUAL N.N	
2N2652	AM	S	N	300	200	100	60	500	0.01	50	50	200	1	50	1 K		4	60	1KHz	15		C32C	DUAL N.N	
2N2696	S	S	P	360	200	25	25	500	25 nA	1	30	130	50	25	1500	26	1200		20			18		
2N2708	AH	S	N	200	200	35	20	50	10 nA	15	30	200	2	30				200 MHz	1.5	9		72		
2N2710	SH	S	N	360	200	40	20	500	30 nA	20	40		10				500		4			18		
2N2720	AM	S	N	300	200	80	60	40	0.01	60	30	120	0.1	30			80		6			C32C	DUAL N.N	
2N2722	AM	S	N	300	200	45	45	40	0.001	30	50	250	1 μA	100			100	10KHz	6			C32C	DUAL N.N	
2N2723	AL	S	N	500	200	80	60	40	0.01		2 K	10K	10	1500			100	1KHz	10			72	DARLINGTON	
2N2728	SHP	G	P	170W	110	15	5	50A				40	130	20A				4.5K*				C7		
2N2785	AL	S	N	500	175	60	40		0.05	30	2 K	20K	100	600			10		30			72	DARLINGTON	
2N2800	SH	S	P	800	200	50	35	800				30	90	150			120		25			5		
2N2802	AM	S	P	250	200	25	20	30	0.01	25	20	120	0.1	20			60	10KHz				C32C	DUAL P.P	
2N2832	SP	G	P	85W	110	80	50	20A	300	2	25	100	10A	2								3		
2N2845	S	S	N	360	200	60	30		200	30	30	120	150				250		8			18		
2N2857	AH	S	N	200	200	30	15	40	0.01	15	30	150	3	50			1000	450 MHz		4		72		
2N2894	S	S	P	360	200	12	12	200	10	6	40	150	30				400		6			18		
2N2895	S	S	N	500	200	120	65	1 A	0.002	60	40	120	150	50			120	1KHz	15			18		
2N2903	AM	S	N	600	200	60	30	50	0.01	50	125	625	1	150	1 K	6	5	60	1KHz	8		C32C	DUAL N.N	
2N2904	SH	S	P	3 W	200	15	60	600	0.02	50	40	120	150				200		8			5		
2N2912	SP	G	P	75W	110	60	6	25A	10 mA	15	75	10	10A				10					C8		
2N2913	AM	S	N	300	200	45	45	30	0.01	45	60	240	10 μA				60	1KHz	4			C32C	DUAL N.N	
2N2929	AH	G	P	750	100	25	10	100	0.15	10	10	100	10				1100	200 MHz		25		5		
2N2944	SC	S	P	400	175	15	10	100	1 nA	15	80		1				15		3.2			46		
2N2947	AP	S	N	25W	175	60	60	1.5A	1	50	2.5	55	400						60			3		
2N2949	AP	S	N	6 W	175	60	60	700	0.1	50	5	100	40						20			107		
2N2951	AP	S	N	3 W	175	60	60	250	0.1	50	20	150	10						8			5		
2N2955	SH	G	P	150	100	40		100				20	60	50						2.5			18	
2N2958	SH	S	N	3 W	200	60	20	600	0.025	50	40	120	150				250		8			5		
2N3009	SH	S	N	360	200	40	15	200				30	120	30			350		5			52		
2N3010	SH	S	N	300	200	15	6	50				25	125	10			600		3			18		
2N3011	SH	S	N	360	200	30	12	200				30	120	10			400		4			18		
2N3012	S	S	P	360	150	12	12	200				30	120	30	4				6			18		

TYPE	TOSHIBA	NEC	HITACHI	MITSUBISHI	MATSUSHITA	FUJITSU	SONY	SANYO	NOTE
2N2242	2SC 594		2SC 689H			2SC 725			
2N2256	2SC 735	2SC 945	2SC1204	2SC 1209		2SC 993			
2N2273		2SA 204	2SA 212						
2N2288			2SB 85						
2N2291			2SB 85						
2N2330	2SC 496	2SC 959			2SC 1407				
2N2357									
2N2368	2SC 594	2SC 764				2SC 725			
2N2369	2SC 594	2SC 764				2SC 725			
2N2369A	2SC 594	2SC 764				2SC 725			
2N2381		2SA 643			2SA 719	2SA 558			
2N2410	2SC 498	2SC 959			2SC 1407				
2N2411	2SA 495	2SA 711	2SA 742			2SA 558			
2N2415								2SA 441	
2N2453									
2N2476		2SC 1266		2SC 450		2SC 1069			
2N2481									
2N2490									
2N2501	2SC 594	2SC 764	2SC 689H			2SC 718		2SC 423	
2N2526	2SA 679						2SB 519		
2N2537	2SC 498	2SC 959			2SC 1407				
2N2604	2SA 497	2SA 579							
2N2635	2SA 599	2SA 603	2SA 673				2SA 480		
2N2639									
2N2652									
2N2696		2SA 643	2SA 565		2SA 719				
2N2708	2SC 378		2SC 462*		2SC 563	2SC 1128			
2N2710	2SC 594	2SC 764	2SC 708					2SC 423	
2N2720									
2N2722									
2N2723									
2N2728									
2N2785									
2N2800		2SA 712			2SA 752				
2N2802									
2N2832			2SB 333		2SB 430				
2N2845	2SC 594					2SC 725			
2N2857	2SC 382	2SC 1320		2SC 773		2SC 724			
2N2894	2SA 467	2SA 603			2SA 550	2SA 559			
2N2895							2SC 1430		
2N2903									
2N2904							2SA 529		
2N2912									
2N2913									
2N2929									
2N2944		2SA 603	2SA 565			2SA 524		2SA 532	
2N2947				2SC 688				2SD 330	
2N2949		2SD 71	2SD 120	2SD 356		2SD 183			
2N2951									
2N2955		2SA 603	2SA 673	2SA 628			2SA 480		
2N2958									
2N3009	2SC 594	2SC 764						2SC 423	
2N3010		2SC 925		2SC 1240					
2N3011	2SC 594	2SC 764						2SC 423	
2N3012	2SA 467	2SA 603				2SA 559			

MOTOROLA

TYPE	USE	MATERIAL	POLARITY	MAXIMUM RATINGS				ELECTRICAL CHARACTERISTICS											OUTLINE TO.	NOTE				
				Pc 25°C (mW)	Tj (°C)	Vas (V)	Vao (V)	Ic (mA)	Iao (μA)	Vas(V) min.	Ic(max) hrc	hfe	hie (Ω)	hre (X10)	hoe (μS)	f _T f _{oe} f _{ao} (MHz)	NF (dB)	Cob (pF)			Cox(fbb) (ps)			
2N3015	SH	S	N	800	200	60	30		200	30	30	120	150					250		8		5		
2N3019	AH	S	N	800	200	140	80	I A	0.01	90	100	300	150	80				100	1KHZ 4	12	400		5	
2N3021	SHP	S	P	25W	175	30	30	3 A			20	60	I A	2									3	
2N3043	AM	S	N	250	200	45	45	30	0.01	45	100	300	10μA	130	3.2K		100	30	10KHZ 5	8		89	DUAL N.N	
2N3049	AM	S	P	250	200	25	20	100	0.01		20	120	10μA	30	750K			60	10KHZ 6	8		89	DUAL P.P	
2N3053	SH	S	N	5 W	200	60	40	700			50	250	150				100		15			5		
2N3055	AP	S	N	115W	200	100	70	15A			20	70	4 A	15			10K*					3		
2N3072	S	S	P	800	200	60	60	500			30	130	50		1.5K	26	1200	130		10		39		
2N3081	SH	S	P	600	200	70	50	600	10nA	50	20		500				150		13			5		
2N3114	AH	S	N	800	200	150	150	200	0.01	100	30	120	30	25	30					9		5		
2N3120	S	S	P	800	200	45	45	500			30	130	50	180	1.5K	26	1200	130		10		18		
2N3127	AH	G	P	100	100	30	20	50	3	10	20	75	3	20			400	200KHZ 5		12		72		
2N3133	SH	S	P	600	200	50	35	600			40	120	150				200		10			5		
2N3137	AH	S	N	600	200	40	20	150		50	20	20	120	50					3.5			5		
2N3209	S	S	P	360	200	20	20	200			30	120	30				400		5			18		
2N3210	SH	S	N	360	200	40	15	500	0.01	20	30	120	10				300		6			18		
2N3211	SH	S	N	360	200	40	15	500			50	150	10				350		4			18		
2N3232	AHP	S	N	117W	200	80	60	7.5A			18	55	3 A	I								3		
2N3244	SH	S	P	1 W	200	40	40	I A	0.05	30	50	150	500				175		25			5		
2N3248	SH	S	P	360	200	15	12				50	150	0.1				250		8			18		
2N3250	SH	S	P	360	200	50	40	200			50	150	10	50	6 K	10	4	250	100KHZ 6	6	250	18		
2N3252	SH	S	N	1 W	200	60	30		0.5	40	30	90	500				200		12			5		
2N3279	AH	G	P	100	100	30	20	50	I	10	10	70	3	10			500	200MHZ 2.9	0.9	5		72		
2N3283	AH	G	P	100	100	25	25	50	2	10	10	10		3	10		400	200MHZ 4	I	10		72		
2N3287	AH	S	P	200	200	40	20	50	0.01	15	15	100	2	15			600	200MHZ 4.5	0.9	8		72		
2N3291	AH	S	N	200	200	25	25	50	0.01	10	10	10		2	10			200MHZ 6	I	15		72		
2N3295	AHP	S	N	800	175	60	60	250	0.1	50	20	60	10						8			5		
2N3296	AHP	S	N	700	175	60	60	700	0.1	50	5	50	40						20			102		
2N3297	AHP	S	N	25W	175	60	60	1.5A	I	50	2.5	35	400						60			3		
2N3298	AHP	S	N	1 W	175	25	15	100	0.01	10	80	240	10						5			18		
2N3299	SH	S	N	800	200	60	30	500			40	120	150				250		8			5		
2N3303	SH	S	N	600	200	25	12	I A			30	120	300				450		15			C94		
2N3304	S	S	P	300	200	6	6				30	120	10				500		3.5			18		
2N3307	AH	S	P	200	200	40	35	50	0.001	15	40	250	2	40			1200	200MHZ 4	I	15		72		
2N3311	AP	G	P	170W	110	30	30	5 A	5 mA	30	60	120	3 A	30			1K*					36		
2N3323	AH	G	P	150	100	35	35	100	0.5	10	30	200	3	30			600		3	100		18		
2N3375	AHP	S	N	11.6W	200	60	40	1.5A			10	100	250				500		8			60		
2N3409	AM	S	N	500	200	60	30	500	0.01	50	30	120	0.1	2.5				1KHZ 4	8			C32C	DUAL N.N	
2N3423	AM	S	N	300	200	30	15	50	0.01	15	20	200	3		45		1200		3			C32C	DUAL N.N	
2N3425	AHP	S	N	300	200	40	15		0.025	20	30	120	10	20			300	6				C32C	DUAL N.N	
2N3427	A	G	P	200	100	45	30	500	3	1.5	100	350	100	200			6**	1KHZ 5	20	5				
2N3445	AP	S	N	115W	200	80	60	7.5A			20	60	3 A	20					260			3		
2N3467	SH	S	P	1 W	200	40	40	I A	0.1	30	40	120	500				175		25			5		
2N3487	AP	S	N	115W	200	80	60	7.5A			20	60	3 A	20					550			61		
2N3494	AH	S	P	600	200	80	80	100	100nA	50	35		100	40	100	2	300	200		7		5		
2N3498	AH	S	N	1 W	200	100	100	500	0.05	50	40	120	150	50	200	2.5	10	150		10		5		
2N3506	SH	S	N	1 W	200	60	40	3 A			40	200	1.5A				60		40			5		
2N3508	SH	S	N	400	200	40	20		0.2	20	40	120	10	5					4			46		
2N3510	SH	S	N	360	200	40	10	500			25	150	150	3.5					4			52		
2N3515	AM	S	N	250	175	80	40	500	0.02	60	50	200	I	50	I K		4	50	1KEZ 6	18		89	DUAL N.N	
2N3544	AH	S	N	300	175	25	25	100	0.01	15	25		10						2.5	10		18		
2N3546	SH	S	P	360	200	15	12				30	120	10				700		6			18		
2N3611	AP	G	P	85W	110	40	30	7 A	40	2	35	70	3 A	15								3		
2N3615	AP	G	P	85W	110	80	60	7 A	60	2	30	60	3 A	15				0.6				3		
2N3634	AH	S	P	1 W	200	140	140	I A	100nA	100	50	150	50	40		3	200	150	1KHZ 3	10		5		

TYPE	TOSHIBA	NEC	HITACHI	mitsubishi	MATSUSHITA	FUJITSU	SONY	SANYO	NOTE
2N3015	2SC 495	2SC 959			2SC1407				
2N3019	2SC 1381	2SC 960							
2N3021	2SB 435				2SC 449				
2N3043									
2N3049									
2N3053	2SC 547		2SC 708	2SC 1155			2SC 1124	2SC614	
2N3055	2SD 111	2SD 151	2SD 341			2SD 250	2SD 340		
2N3072		2SA 607							
2N3081		2SA 708					2SA 706		
2N3114	2SC 484			2SC 310					
2N3120	2SA 503				2SA 546	2SA 580			
2N3127	2SA 776A	2SA 579	2SA 673	2SA 725			2SA 705		
2N3133		2SA 607							
2N3137	2SC 497	2SC 139	2SC 154C						
2N3209	2SA 467	2SA 603						2SC 532	
2N3210	2SC 504					2SC 906		2SC 423	
2N3211	2SC 504					2SC 906		2SC 423	
2N3232		2SD 151				2SD 196			
2N3244		2SA 613	2SA 715		2SA 684				
2N3248	2SA 467	2SA 603			2SA 550				
2N3250	2SA 467	2SA 603			2SA 550				
2N3252	2SC 513	2SC 959	2SC 1385						
2N3279	2SA 776A	2SA 579	2SA 673	2SA 725			2SA 705		
2N3283	2SA 776A	2SA 579	2SA 673	2SA 725			2SA 705		
2N3287	2SA 776A	2SA 579	2SA 673	2SA 725			2SA 705		
2N3291	2SC 371	2SC 606			2SC 563		2SC 1128		
2N3295	2SC 501	2SC 959							
2N3296	2SC 501	2SC 959							
2N3297	2SC 790	2SD 288	2SC 1061		2SD 317		2SD 292		
2N3298	2SC 495	2SC 959							
2N3299	2SC 495	2SC 959							
2N3303			2SC 1212A		2SC 1383				
2N3304	2SA 467	2SA 603	2SA 530		2SA 550				
2N3307	2SA 561		2SA 530			2SA 558			
2N3311									
2N3323			2SA 549 A	2SA 696		2SA 555			
2N3375	2SC 1196								
2N3409									
2N3423									
2N3425									
2N3427		2SB 226				2SB 427			
2N3445		2SD 151							
2N3467					2SA 752				
2N3487		2SD 151							
2N3494	2SA 497								
2N3498	2SC 497	2SC 959							
2N3506									
2N3508	2SC 594							2SC 423	
2N3510	2SC 594							2SC 423	
2N3515									
2N3544	2SC 594					2SC 718		2SC 423	
2N3546	2SA 467				2SA 550	2SA 559			
2N3611	2SB 530						2SB 519		
2N3615	2SB 530						2SB 519		
2N3634							2SA 762		

MOTOROLA

TYPE	USE	MATERIAL	POLARITY	MAXIMUM RATINGS				ELECTRICAL CHARACTERISTICS												OUTLINE TO-	NOTE								
				Pc 25°C (mW)	Tj (°C)	Vas (V)	Vcbo (V)	Ic (mA)	Icbo (μA)	Vas(V)	hFE		hfe	hie (Ω)	hre (x10)	hoe (μS)	fT fα fβ fαβ (MHz)	NF (dB)	Cob (pF)			Cstrbb (ps)							
2N3664	AHP	S	N	5 W	200	60	60	500				8	80	50									6		102				
2N3712	AH	S	N	800	200	150	150	200	0.1	75	30	150	30	25									24 0	9	100	5			
2N3713	AHP	S	N	150W	200	80	60	10A			25	75	1 A	2.5												3			
2N3719	SHP	S	P	6 W	200	40	40	3 A	10	40	25	180	1 A									60		120		5			
2N3722	S	S	N	800	200	80	60	500			40	150	100									300		10		5			
2N3726	AM	S	P	400	200	45	45	300	10 nA	30	135	350	1	420	11.5K	15	80	600	10KHz	4		8					DUAL P.P		
2N3733	AHP	S	N	23W	200	65	40	3 A			10	150	250									400		20		60			
2N3734	SH	S	N	1 W	200	50	30	1.5A			30	120	1 A	2.5										9		5			
2N3738	AP	S	N	20W	175	250	225	3 A	100	250	40	200	100	35								10		20		66			
2N3740	AP	S	P	25W	200	60	60	4 A	100	60	30	100	250	25								3		100		66			
2N3742	AH	S	N	1 W	200	300	300	50	0.2	200	20	200	30	20	500	1	50								6		5		
2N3743	AH	S	P	1 W	200	300	300	50	0.3	200	25	250	30	30	1000	4	200								15		5		
2N3762	SH	S	P	1 W	200	40	40	1.5A			30	120	1 A												15		5		
2N3766	AP	S	N	20W	175	80	60	4 A	100	80	40	160	500	40								10			50		66		
2N3771	AP	S	N	150W	200	50	40	30A	2 mA	15	60	15A	40	40								0.2					3		
2N3783	AH	G	P	150	100	30	20	20	5	10	20	200	3	20								800		1	6		72		
2N3789	AP	S	P	150W	200	60	60	10A			25	90	1A									4					3		
2N3798	A	S	P	360	200	60	60	50	0.01	50	150	450	0.5		3 K	25	60					100 MHz		4			18		
2N3800	A	S	P	250	200	60	60	50	0.01	50	150	450	0.1	150	3 K	25	60	500	100KHz	4				4		71	DUAL P.P		
2N3804A	AM	S	P	250	200	60	60	50	0.01	50	150	450	0.1	600	15K	25	60	500	100KHz	4				4		71	DUAL P.P		
2N3818	AHP	S	N	25W	175	60	60	2 A	1	50	5	50	400												40		60		
2N3838	SH	S	N,P	250	200	60	40	600			100	300	150		1.5		50	200	1 KEZ	8				8		89	DUAL N.P		
2N3866	AHP	S	N	5 W	200	55	30	400			10	200	50									800				2	39		
2N3883	SH	G	P	300	100	25	15	300			30		200									300				4.5	5		
2N3903	SH	S	N	310	135	60	40	200			50	150	10	50	500	0.1	1	250	10KHz	6					4		92		
2N3905	SH	S	P	310	135	40	40	200			50	150	10	50	500	0.1	1	200							4.5		92		
2N3924	AHP	S	N	7 W	200	36	18	500	100	15				50	500	10	1	350							12.5		102		
2N3946	SH	S	N	360	200	60	40	200			50	150	10									250	10KHz	5	4	200	18		
2N3948	AHP	S	N	1 W	200	36	20	400	0.1	15	15		50									700			4.5		39		
2N3950	AHP	S	N	70W	200	65	35	3.3A	10mA													150			80		60		
2N3959	SH	S	N	400	200	20	12				40	200	10									1000			2.5	30	18		
2N4012	AP	S	N	11.6W	200	65	40	1.5A			4	40	1A									500			10		60		
2N4015	AM	S	P	400	200	60	60	300	10 nA	50	135	350	1	420	11.5K	15	80	600	10KHz	4				8				DUAL P.P	
2N4048	AP	G	P	170W	110	45	30	60A	200	2	60	120	15A									2 K *						C7	
2N4072	AHP	S	N	1.5W	200	40	20	100	0.1	15	10		25A									550			3		18		
2N4123	SH	S	N	310	135	40	30	200	50 nA	20	50	150	2	50								250	10KHz	6	4		92		
2N4125	SH	S	P	310	135	30	30	200	50 nA	20	50	150	2	50								200	10KHz	5	4.5		92		
2N4231	AP	S	N	60W		90	80	3 A	50	50	10	80	1A	20								4			200		66		
2N4234	AH	S	N	200	200	30	30	3 A	100	40	30	150	250	25								3			100		5		
2N4237	SP	S	N	360	200	40	1 A	100	40	40	120	10	30									2			100		5		
2N4260	SH	S	P	200	200	15	15	30			30	150	10									1200			2.5	35	72		
2N4264	S	S	N	310	135	30	15	200			40	160	10									300			4		92		
2N4276	AP	G	P	170W	110	30	20	60A	200	2	60	120	15A									2 K *					3		
2N4398	AP	S	P	200W	200	40	40	30A	1 mA	40	15	60	15A	40								4					3		
2N4400	SH	S	N	310	135	60	40	600			50	150	150	20	500	0.1	1	200							65		92		
2N4402	SH	S	P	310	135	40	40	600			50	150	150	30	750	0.1	1	150							8.5		92		
2N4404	A	S	P	5 W		80	80	1 A	25 nA	60	40	120	150									600				10	39		
2N4406	A	S	P	5 W		80	80	2 A	25 nA	60	30	120	500									750				15	39		
2N4409	S	S	N	310	135	80	50	250	0.01	60	60	400	1									300				12	92		
2N4427	AP	S	N	3.5W		40	20	400			10	200	100									500				4	39		
2N4428	AP	S	N	3.5W		55	35	425			20	200	50									1000				1.2	39		
2N4890	S	S	P	1 W		60	40	500			50	250	150									2 80			9		39		
2N4898	AP	S	P	25W	200	40	40	1 A	100	40	20	100	500	25								3			100		66		
2N4901	AP	S	P	87.5W	200	40	40	5 A	100	40	20	80	1 A	20								4					3		
2N4904	AS	S	P	87.5W	200	40	40	5 A	100	40	25	100	2.5A	40								4					3		

TYPE	TOSHIBA	NEC	HITACHI	mitsubishi	MATSUSHITA	FUJITSU	SONY	SANYO	NOTE
2N3664	2SC 547			2SC 700	2SC575			2SC614	
2N3712		2SC49							
2N3713	2SD 113	2SD 151							
2N3719	2SB 462								
2N3722	2SC 497	2SC 149				2SC 233		2SC 614	
2N3726									
2N3733	2SC 789	2SC 1037							
2N3734	2SC 485					2SC916			
2N3738							2SD56		
2N3740	2SB64				2SB 512			2SB 507	
2N3742	2SC 996						2SC 1056		
2N3743									
2N3762		2SA 613			2SA 752				
2N3766			2SC1055					サンケン	
2N3771						2SD 249		2SC1444	
2N3783					2SA 310				
2N3789									
2N3798	2SA 502	2SA 603	2SA 530H		2SA 550				
2N3800									
2N3804A									
2N3818	2SC 1077								
2N3838									
2N3866				2SC1155	2SC 700				
2N3883	2SA 467	2SA 603							
2N3903		2SC 603							
2N3905	2SA 467	2SA 603							
2N3924		2SC 891			2SC 1074				
2N3946	2SC 594					2SC 725			
2N3948		2SC 959		2SC1016					
2N3950				2SC1020					
2N3959		2SC 852				2SC 1068			
2N4012									
2N4015									
2N4048									
2N4072					2SC 821	2SC854			
2N4123	2SC 594	2SC 729				2SC 565			
2N4125	2SA 467	2SA 603							
2N4231			2SC 1030						
2N4234									
2N4237									
2N4260	2SA 561		2SA 530H			2SA 559			
2N4264	2SC 594		2SC 689						
2N4276									
2N4398									
2N4400	2SC 1382			2SC1211		2SC1247A			
2N4402					2SA 720				
2N4404		2SA 652			2SA 547A		2SA761		
2N4406		2SA 652			2SA 547A		2SA761		
2N4409	2SC 511	2SC 1218							
2N4427	2SC 1196			2SC1323	2SC 731				
2N4428	2SC 1196			2SC1323	2SC 731				
2N4890		2SB 109A							
2N4898	2SB 425	2SB 250A			2SB 127A	2SB42			
2N4901		2SA 649							
2N4904		2SA 649							

MOTOROLA

TYPE	USE	MATERIAL	POLARITY	MAXIMUM RATINGS						ELECTRICAL CHARACTERISTICS													OUTLINE TO:	NOTE	
				Pc 25°C (mW)	Tj (°C)	Vas (V)	VasD (V)	Ic (mA)	I _{EO} (μA)	Vas(V)	hFE		hFE	hie (Ω)	hre (X10)	hoe (μS)	ft *f _{oe} **f _{ao} (MHz)	NF (dB)	Cob (pF)	Cokb (ps)					
2N4910	AP	S	N	25W	200	40	40	1 A	100	40	20	100	500	25				3		100			66		
2N4913	AP	S	N	87.5W	200	40	40	5 A	1 mA		25	100	2.5A	20				4					3		
2N4918	AP	S	P	30W	150	40	40	1 A	100	40	20	100	500	25				3		100			C77		
2N4921	AP	S	N	30W	150	40	40	1 A	100	40	20	100	500	25				3		100			C77		
2N4924	AH	S	N	1W	175	100	100	200	0.1	50	40	200	150					500		10			39		
2N4926	AH	S	N	1W	175	200	200	50	0.1		25	200	30	25	75K	0.1	5	300		6			39		
2N4928	A	S	P	3W		100	100	100	0.5		25	200	10				1000		6				39		
2N4937	AM	S	P	600	200	50	40	50	2 nA	40	50	250	1	50	4 K	3	15	400	10KHz 4	3		C32	DUAL P.P		
2N4957	A	S	P	200	200	30	30	30	0.1	20	20	40	2				1600	450KHz 2.5		8			72		
2N4974	AL	S	P	800	200	40	30	1 A			5 K	9 K	1 μA	2500				275	10KHz 3			12	DARLINGTON		
2N5016	AHP	S	N			65	30	4.5A			10	200	500					500		20			60		
2N5031	AH	S	N	200		15	10	20	1 nA		25	300	1					3500	450KHz 2.5	1.3	5		72		
2N5050	AP	S	N	40W	200		120	2A			35	105	500	25				10		250			66		
2N5067	AP	S	N	87.5W	200	40	40	5 A	1 mA	40	20	80	1 A	20				4					3		
2N5070	AHP	S	N	70W		65	30	3.3A	10mA		10	100	3 A					100				85		60	
2N5086	A	S	P	310	135	50	50	50	10 nA	10	150	500	0.1	150				175	1KHz 3		4			92	
2N5088	A	S	N	310	135	35	30	50	50 nA	20	300	900	0.1	350				120	10KHz 3					92	
2N5090	AHP	S	N		200	55	30	400			10	200	50					500		3.5				60	
2N5108	AHP	S	N	3.5W		55	55	400										1200		1.3				39	
2N5155	SP	G	P		110	140	120	15A	200	2	25	100	8 A					100						3	
2N5160	AHP	S	P	5W		60	40	400	1	28	10		50					900						39	
2N5161	AHP	S	P	20W		60	40	1.5A	100	28	10		250					500		10				60	
2N5179	AH	S	N	200		20	12	50	0.02	15	25	250	3	25				2000	200KHz 4.5			3		72	
2N5190	AP	S	N	40W	150	40	40	4 A	100	40	25	100	1.5A					2						C77-1	
2N5193	AP	S	P	40W	150	40	40	4 A	100	40	25	100	1.5A					2						C77-1	
2N5208	AH	S	P	310		30	25	50	10 nA	10	20	120	2					1200				10		92	
2N5209	A	S	N	310		50	50	50	10 nA	10	100	300	0.1	150				80	1KHz 3					92	
2N5219	A	S	N	310		20	15	100	0.1	10	35	500	2	35				150						92	
2N5220	A	S	N	310		15	15	500	0.1	10	30	600	50	30				100						92	
2N5221	A	S	P	310		15	15	500	0.1	10	30	600	50	30				100						92	
2N5222	A	S	N	310		20	15	50	0.1	10	20	1500	4	20				450						92	
2N5223	A	S	N	310		25	20	100	0.1	10	50	800	2	50				150						92	
2N5224	SH	S	N	310		25	12		0.5	15	40	400	10					250						92	
2N5225	A	S	N	310		25	25	500	0.3	15	30	600	50	30				50						92	
2N5226	A	S	P	310		25	25	500	0.3	15	30	600	50	30				50						92	
2N5227	A	S	P	310		30	30	50	0.1	10	50	700	2	50				100						92	
2N5228	SH	S	P	310		5	5	50			30		10					300						92	
2N5229	SC	S	P	2W		15	10	50	1 nA		50		100 μA	2										46	
2N5301	AP	S	N	200W	200	40	40	30A	1 mA	40	15	60	15A	40				2						3	
2N5324	SP	G	P	56W	110	250	150	10A			20	60	5 A					2						3	
2N5332	SH	S	P	360		20	12	100	10 nA		20	80	1					600						46	
2N5334	SP	S	N	6W	200	60	60	3 A	5	60	30	150	1 A					40		75				39	
2N5336	SP	S	N	6W	200	80	80	5 A	10	80	30	120	2A					30		250				39	
2N5344	SP	S	P	40W	200	250	250	1 A	100	250	25	100	500					60		200				66	
2N5346	SP	S	N	60W	200	80	80	7 A	10	80	30	120	2A					30		250				59	
2N5357	SP	S	P	30W	200	300	300	3 A			25	100	500					50		60				37	
2N5400	A	S	P	310		130	120	600	0.1	100	40	180	10	30				400	10KHz 4					92	
2N5427	SP	S	N	35W	200	80	80	7 A	10	80	30	120	2A					30		250				66	
2N5435	SP	G	P	120W	110	80	60	60A	200	2	20	60	25A					0.35						3	
2N5477	SP	S	N	60W	200	80	80	7 A	10	80	30	120	2A					30		250				59	
2N5550	A	S	N	310		160	140	600	0.1	100	60	250	10	50				300	10KHz 10		6			92	
2N5581	SH	S	N	2W		75	40		0.01	60	40	120	150	30	1 K	5	3	250			150			46	
2N5583	SH	S	N	5W		30	30	500	50 nA	20	25	100	100					1300			8			39	
2N5629	AP	S	N	200W	200	100	100	16A	1 mA	100	25	100	8A	15				1		500				3	
2N5632	AP	S	N	150W	200	100	100	10A	1 mA	100	25	100	5 A	15				1		300				3	

TYPE	TOSHIBA	NEC	HITACHI	MITSUBISHI	MATSUSHITA	FUJITSU	SONY	SANYO	NOTE
2N4910					2SD317				
2N4913		2SD322							
2N4918		2SB250A			2SB127A	2SB42		2SB216	
2N4921					2SD317				
2N4924	2SC1382						2SC1124	2SC614	
2N4926	2SC996		2SC685A				2SC1127		
2N4928									
2N4937									
2N4957	2SA561	2SA711	2SA530H						
2N4974									
2N5016									
2N5031	2SC1193	2SC1270				2SC1460			
2N5050	2SD119				2SD12	2SD175		2SD67	
2N5067		2SD151	2SD125A			2SD53			
2N5070		2SC1037							
2N5086	2SA502	2SA675		2SA668					
2N5088	2SC734				2SC538A	2SC964			
2N5090									
2N5108				2SC1323	2SC731	2SC1068			
2N5155									
2N5160									
2N5161									
2N5179		2SC1424							
2N5190								2SD315	
2N5193							2SB518	2SB509	
2N5208	2SA561	2SA711				2SA559			
2N5209	2SC734				2SC538A			2SC1210	
2N5219	2SC734				2SC538A	2SC964		2SC1210	
2N5220	2SC498			2SC1209	2SC1383				
2N5221		2SA643			2SA719				
2N5222	2SC734				2SC538A	2SC964		2SC1210	
2N5223	2SC734				2SC538A	2SC964		2SC1210	
2N5224	2SC735			2SC1209	2SC538A			2SC933	
2N5225	2SC498			2SC1209	2SC1383				
2N5226		2SA643			2SA719				
2N5227	2SA561	2SA711				2SA558			
2N5228	2SA561	2SA711				2SA558			
2N5229									
2N5301									
2N5324								2SB491	
2N5332		2SA710	2SA742H			2SA558			
2N5334		2SD155	2SC1060		2SD226B	2SD148	2SD28		
2N5336		2SD283							
2N5344									
2N5346	2SD371	2SD188					2SD338		
2N5357								2SB412	
2N5400		2SA712							
2N5427	2SD119				2SD189A				
2N5435									
2N5477	2SD371	2SD188					2SD338		
2N5550	2SC510								
2N5581									
2N5583		2SC1333				2SC1355			
2N5629									
2N5632							2SD340		

MOTOROLA

TYPE	USE	MATERIAL	POLARITY	MAXIMUM RATINGS					ELECTRICAL CHARACTERISTICS													OUTLINE TO:	NOTE	
				Pc 25°C (mW)	Tj (°C)	Vas (V)	Vas (V)	Ic (mA)	Iao (μA)	Vas(V)	hFE			hfe	hie (Ω)	hre (×10)	hoe (μS)	fT at Iao **Iao (MHz)	NF (dB)	Cob (pF)	Ccst (ps)			
2N5655	AP	S	N	20W	150	275	250	500	10	275	30	250	100	20				10		25		C77-02		
2N5679	AP	S	P	10W	200	100	100	1A	1	100	40	150	250	40				30		50		5		
2N5681	AP	S	N	10W	200	100	100	1A	1	100	40	150	250	40				30		50		5		
2N5683	AP	S	P	300W	200	60	60	50A	2 mA	60	15	60	25A	15				2		2000		3		
2N5685	AP	S	N	300W	200	60	60	50A	2 mA	60	15	60	25A	15				2		1200		3		
2N5692	AP	G	P	125W	110	50	30	40A	200	2	20	65	25A				0.2					3		
2N5763	SP	S	P	400		65	60	600	10 nA	50	70		10				200		8			18		
2N5793	SH	S	N	500		75	40	600	10 nA	50	40	120	150				250					C.654 -34	DUAL N.N	
2N5795	SH	S	P	500		60	60	600	20 nA	50	40	120	150				200		8			C.654 -04	DUAL P.P	
2N5829	AH	S	P	200	125	30	30	30	0.1	20	20	150	2	20			1600	450 MHz 2,3		8		72		
2N5835	SH	S	N	200	125	5	10	15	0.01	7.5	25		10				2.5G			5		46		
2N5841	SH	S	N	350		20	10	100	0.02	10	25	200	25				2.6G			18		72		
2N5843	AM	S	P	300		50	40	50	0.01	50	50	150	0.1	200	6 K	10	40	200	1 MHz 6				C.654 -04	DUAL P.P
2N5845	SH	S	N	500		50	40	600	0.5	40	25	150	500				200		9			92		
2N5851	S	S	N	500		30	15	100	1	15	40		10				850	200 MHz 2,5		10		72		
2N5864	S	S	P	1.25W		90	70	1.5A	0.5	45	50	500	150	50	200	5	10	50				39		
2N5865	S	S	P	1.25W	7 W	70	50	1 A	0.2	35	40	200	150				100					39		
2N5867	AP	S	P	87.5W	200	60	60	3 A	100	60	20	100	1.5A	20			4		200		3			
2N5871	AP	S	P	100W	200	60	60	5 A	250	60	20	100	2.5A	20			4		300		3			
2N5875	AP	S	P	150W	200	60	60	8 A	500	60	20	100	4 A	20			4		500		3			
2N5879	AP	S	P	160W	200	60	60	12 A	500	60	20	100	6 A	20			4		600		3			
2N5883	AP	S	P	200W	200	60	60	20A	1 mA	60	20	100	10A	20			4		800		3			
2N5943	A	S	N	3.5W		40	30	400	100	15	25	300	50	25			1350	200 MHz 3,4		5.5		39		

RCA

RCA

TYPE	USE	MATERIAL	POLARITY	MAXIMUM RATINGS						ELECTRICAL CHARACTERISTICS										OUTLINE TO.	NOTE							
				Pc 25°C (mW)	Tj (°C)	Vas (V)	Vcco (V)	Ic (mA)	Icse (μA)	Vce/V	Icse min.	Icse max.	Ic(mA)	hfe	hie (Ω)	hre (×10)	hoe (Ω)	f _T *f _{osc} **f _{ob} (MHz)	NF (dB)			Cob (pF)	Cox/βb (ps)					
2N176	AH	G	P	10W										65											3			
2N217	A	G	P	160		35								50												1		
2N274	AH	G	P	120		40																				44		
2N301	AP	G	P	30W		60								50	165													
2N301A	AP	G	P	30W		80								50	165													
2N351	AP	G	P	10W		40								65												3		
2N376	AP	G	P	10W		40								78												3		
2N404	S	G	P	150		25								20								4				5		
2N414	AH	G	P	150		30																8				5		
2N697	S	S	N	2W	175	60	40	500	0.01	30	40	120	150								100				20	5		
2N699	S	S	N	2W	175	120	80		2	25	40	120	150												20	5		
2N718A	AH	S	N	1.8W		75						40	120														18	
2N720	AH	S	N	1.8W		120						40	120														18	
2N1066	AH	G	P	120		40																					33	
2N1183	SP	G	P	1W		45								20													8	
2N1183A	SP	G	P	1W		60								20													8	
2N1183B	SP	G	P	1W		80								20													8	
2N1184	SP	G	P	1W		45								40													8	
2N1184A	SP	G	P	1W		60								40													8	
2N1184B	SP	G	P	1W		80								40													8	
2N1224	SH	G	P	120		40																					33	
2N1225	AH	G	P	120		40																					33	
2N1226	AH	G	P	120		60																					33	
2N1285	AH	G	P	120		40								30	100												33	
2N1395	AH	G	P	120		40																					33	
2N1396	AH	G	P	120		40																					33	
2N1397	AH	G	P	120		40																					33	
2N1479	SP	S	N	5W	200	60	40	1.5A	10	30	20	60	200												150	5		
2N1480	SP	S	N	5W	200	100	55	1.5A	10	30	20	20	200												150	5		
2N1481	SP	S	N	5W	200	60	40	1.5A	10	30	35	100	200												150	5		
2N1482	SP	S	N	5W	200	100	55	1.5A	10	30	35	100	200												150	5		
2N1483	SP	S	N	25W	200	60	40	3A	15	30	20	60	750												175	8		
2N1484	SP	S	N	25W	200	100	55	3A	15	30	20	60	750												175	8		
2N1485	SP	S	N	25W	200	60	40	3A	15	30	35	100	750												175	8		
2N1486	SP	S	N	25W	200	100	55	3A	15	30	35	100	750												175	8		
2N1487	SP	S	N	75W	200	60	40	6A	25	30	15	45	1.5A												200	3		
2N1488	SP	S	N	75W	200	100	55	6A	25	30	15	45	1.5A												200	3		
2N1489	SP	S	N	75W	200	60	40	6A	25	30	25	75	1.5A												200	3		
2N1490	SP	S	N	75W	200	100	55	6A	25	30	25	75	1.5A												200	3		
2N1613	S	S	N	3W	200	75	50	1A	0.01	60	20		0.1	100								1KHZ 2			25	5		
2N1683	SH	G	P	150		13								85								50					5	
2N1700	S	S	N	5W	200	60	40	1A	75	30	20	80	100														5	
2N1701	S	S	N	25W	200	60	40	2.5A	100	30	20	80	300														8	
2N1702	S	S	N	75W	200	60	40	5A	200	30	15	60	800														3	
2N1711	S	S	N	3W	200	75	50	1A	0.01	60	35		10												8	25	5	
2N1893	AH	S	N	3W	200	120	80	500	0.01	90	40	120	150														5	
2N1905	AP	G	P	30W		100								50	150												3	
2N1906	AP	G	P	30W		130								75	250												3	
2N2015	A	S	N	150W	200	100	50	10A	50	30	15	50	5A														36	
2N2016	A	S	N	150W	200	130	65	10A	50	30	15	50	5A														36	
2N2102	SH	S	N	5W	200	120	80	1A	0.002	60	20		0.1	125											1KHZ 8	15	5	
2N2147	AP	G	P	12.5W		75								100	300										3		3	
2N2148	AP	G	P	12.5W		60								60											2		3	
2N2270	A	S	N	5W	200	60	60	1A	0.1	60	50	200	150												1KHZ 8	15	5	
2N2338	AP	S	N	150W	200	60	40	7.5A	200	30	15	60	3A														36	

TYPE	TOSHIBA	NEC	HITACHI	mitsubishi	MATSUSHITA	FUJITSU	SONY	SANYO	NOTE
2N176									
2N217									
2N274									
2N301									
2N301A									
2N351									
2N376									
2N404									
2N414									
2N697		2SC1266							
2N699		2SC1266							
2N718A									
2N720									
2N1066									
2N1183									
2N1183A									
2N1183B									
2N1184									
2N1184A									
2N1184B									
2N1224									
2N1225									
2N1226									
2N1285									
2N1395									
2N1396									
2N1397									
2N1479	2SD525		2SD120	2SD361					
2N1480	2SD 524		2SD121						
2N1481	2SD 525		2SD120	2SD361					
2N1482	2SD 524		2SD121						
2N1483		2SD335							
2N1484		2SD335							
2N1485		2SD335							
2N1486		2SD335							
2N1487		2SD217					2SD338		
2N1488		2SD217					2SD338		
2N1489		2SD217					2SD338		
2N1490		2SD217					2SD338		
2N1613			2SD121						
2N1683									
2N1700	2SD234			2SD361			2SD292		
2N1701	2SC 789	2SD335							
2N1702	2SD111						2SD338		
2N1711			2SD121						
2N1893			2SD121						
2N1905									
2N1906									
2N2015	2SD113					2SD197A		(2SD208新電元)	
2N2016	2SD113					2SD197A		(2SD208新電元)	
2N2102		2SD152				2SD158			
2N2147									
2N2148									
2N2270	2SD234			2SD361			2SD292	2SD325	
2N2338	2SD113								

RCA

TYPE	USE	MATERIAL	POLARITY	MAXIMUM RATINGS							ELECTRICAL CHARACTERISTICS										OUTLINE TO.	NOTE				
				Pc 25°C (mW)	Tj (°C)	Vok (V)	Vc00 (V)	ic (mA)	Ic00 (μA)	V00(V)	min.	max.	ic(mA)	hfe	hie (Ω)	hre (×10 ⁴)	hoe (μS)	fr *f2B (MHZ)	NF (dB)	Cob (pF)			Coxr/b (ps)			
2N2405	A	S	N	5W	200	120	90	1A	0.01	90	60	200	150											5		
2N2869	AP	G	P	30W		60					50	165					0.2							3		
2N2870	AP	G	P	30W		80					50	165					0.2							3		
2N2895	S	S	N	1.8W	200	120	65	1A	0.002	60	40	120	150					8	15					18		
2N2896	S	S	N	1.8W	200	140	90	1A	0.01	90	60	200	150						15					18		
2N2897	S	S	N	1.8W	200	60	45	1A	0.05	60	50	200	150						15					18		
2N3053	SH	S	N	5W	200	60			700	0.25	30	50	250	150										5		
2N3054	AP	S	N	25W	200	90	55	4A	500	30	25	100	500				0.8							66		
2N3055	AP	S	N	115W	200	100	60	15A			20	70	4A				0.8							3		
2N3263	SP	S	N	20W		150	90	25A	4mA	80	25	75	15A				20		500					63		
2N3264	SP	S	N	30W		120	60	25A	10mA	60	20	80	15A				20		500					63		
2N3265	SP	S	N	24W		150	90	25A	4mA	80	25	75	15A				20		500					63		
2N3266	SP	S	N	28W		120	60	25A	10mA	60	20	80	15A				20		500					63		
2N3439	AH	S	N	10W	200	450	350	1A			40	160	20						10					5		
2N3440	AH	S	N	10W	200	300	250	1A			40	160	20						10					5		
2N3441	AP	S	N	25W	200	160	140	3A			25	100	50				0.8							66		
2N3442	AP	S	N	117W	200	160	140	10A	1mA	140	20	70	3A											3		
2N3583	AHP	S	N	2.5W	200	250	175	1A			40		100												66	
2N3584	SP	S	N	2.5W	200	375	250	2A			25	100	1A												66	
2N3585	SP	S	N	2.5W	200	500	300	2A			25	100	1A												66	
2N3730	AP	G	P	10W		200					10	200													3	
2N3731	AP	G	P	5W		320					15														3	
2N3732	AP	G	P	3W		100					35	500													3	
2N3771	AP	S	N	150W	200	50	40	30A	2mA	50	15	60	15A												3	
2N3772	AP	S	N	150W	200	100	60	20A	5mA	100	15	60	10A												3	
2N3773	AP	S	N	150W	200	160	140	16A	2mA	140	15	60	8A												3	
2N3878	AHP	S	N	35W	200	120	50	7A	5mA	40	50	200	500	6					175						66	
2N3879	SP	S	N	35W	200	120	90	7A	5mA	40	20	80	4A	6					175						66	
2N4036	S	S	P	7W	200	90	65	1A	100	90	20	200	150												5	
2N4037	S	S	P	7W	200	60	40	1A	0.25	60	50	250	150												5	
2N4063	AP	S	N	10W	200	450	350	1A			40	160	20						10						5	
2N4064	AP	S	N	10W	200	300	250	1A			40	160	20						10						5	
2N4240	AP	S	N	2.5W	200	500	300	2A			30	150	750												66	
2N4314	AP	S	P	7W	200	90	65	1A	0.25	30	50	250	150												5	
2N4346	AP	S	P	5W		320																			3	
2N4347	AP	S	N	100W	200	140	120	5A			15	60	2A												3	
2N4348	AP	S	N	120W	200	140	120	10A			15	60	5A												3	
2N5034	AP	S	N	83W	150	55	40	6A			20	80	4A												219AA	
2N5035	AP	S	N	83W	150	55	40	6A			20	80	4A												219AB	
2N5036	AP	S	N	83W	150	70	50	8A			20	80	5A												219AA	
2N5037	AP	S	N	83W	150	70	50	8A			20	80	5A												219AB	
2N5038	SP	S	N	140W	200	150	90	20A			50	200	2A				60		300						3	
2N5039	SP	S	N	140W	200	120	75	20A			30	150	2A				60		300						3	
2N5189	SH	S	N	5W		60	35	1A	0.5	30	30		100	2.5					15						39	
2N5202	SP	S	N	35W	200	120	4A	5mA	40	10	100	4A	6						175						66	
2N5239	AP	S	N	100W	200	300	225	5A			20	80	2A	20					150						3	
2N5240	AP	S	N	100W	200	375	300	5A			20	80	2A	20					150						3	
2N5262	SH	S	N	5W	200	75	50	2A	10	60	35		100						9						39	
2N5293	AP	S	N	36W	150	80	70	4A			30	120	500				0.8								66	
2N5294	AP	S	N	36W	150	80	70	4A			30	120	500				0.8								66	
2N5295	AP	S	N	36W	150	60	40	4A			30	120	1A				0.8								66	
2N5296	AP	S	N	36W	150	60	40	4A			30	120	1A				0.8								66	
2N5297	AP	S	N	36W	150	80	60	4A			20	80	1.5A				0.8								66	
2N5298	AP	S	N	36W	150	80	60	4A			20	80	1.5A				0.8								66	
2N5320	SP	S	N	10W		100	75	2A	0.5	80	30	130					50								5	

TYPE	TOSHIBA	NEC	HITACHI	mitsubishi	MATSUSHITA	FUJITSU	SONY	SANYO	NOTE
2N2405		2SD152		2SD358		2SD158			
2N2869									
2N2870									
2N2895			2SD121						
2N2896			2SD121						
2N2897			2SD121			2SD149			
2N3053	2SD131			2SD361			2SD292		
2N3054		2SD297							
2N3055			2SD341				2SD340		
2N3263									
2N3264									
2N3265									
2N3266									
2N3439		2SC1101			2SD199				
2N3440		2SC1101			2SD198				
2N3441		2SD283					2SD56		
2N3442		2SD286							
2N3583					2SD198	2SD159	2SC867		
2N3584	2SC643		2SC937			2SD159			
2N3585	2SC643		2SC937						
2N3730									
2N3731									
2N3732									
2N3771						2SD249			
2N3772						2SD250			
2N3773						2SD250	2SD262		
2N3878		2SD323							
2N3879		2SD323							
2N4036				2SB526					
2N4037				2SB526					
2N4063		2SC1101			2SD199				
2N4064		2SC1101			2SD198				
2N4240	2SC643		2SC937						
2N4314				2SB526					
2N4346									
2N4347	2SD110	2SD218					2SD340		
2N4348							2SD340		
2N5034					2SD334	2SD157			
2N5035					2SD334	2SD157			
2N5036	2SD110	2SD218					2SD339		
2N5037	2SD110	2SD218					2SD339		
2N5038						2SC1301			
2N5039	2SD113	2SD132							
2N5189	2SD234			2SD361			2SD292		
2N5202	2SD110	2SD218				2SD177			
2N5239							2SD262		
2N5240							2SD262		
2N5262		2SD143	2SD121		2SD226B		2SD292		
2N5293	2SD110	2SD218				2SD175	2SD88A-2		
2N5294	2SD110	2SD218				2SD175	2SD88A-2		
2N5295	2SD110	2SD218				2SD175	2SD88A-2		
2N5296	2SD110	2SD218				2SD175	2SD88A-2		
2N5297	2SD110	2SD218				2SD175	2SD88A-2		
2N5298	2SD110	2SD218				2SD175	2SD88A-2		
2N5320		2SD285							

RCA

TYPE	USE	MATERIAL	POLARITY	MAXIMUM RATINGS					ELECTRICAL CHARACTERISTICS											OUTLINE TO.	NOTE				
				Pc 25°C (mW)	Tj (°C)	Vas (V)	Vceo (V)	Ic (mA)	I _{ceo} (μA)	V _{ceV}	h _{FE}		h _{FE}	h _{ie} (Ω)	h _{re} (×10 ⁻⁴)	h _{oe} (μS)	f _T *f _{ce} **f _{ob} (MHz)	NF (dB)	C _{ob} (pF)			C _{ox} (ps)			
2N5321	SP	S	N	10W		75	50	2A	5	60	40	250					50						5		
2N5322	SP	S	P	10W		100	75	2A	0.5	80	30	130					50						5		
2N5323	SP	S	P	10W		75	50	2A	5	60	40	250					50						5		
2N5415	AH	S	P	10W	200	200	200	1A	50	150	30	150	50	25								15		5	
2N5416	AH	S	P	10W	200	350	300	1A	50	250	30	120	50	25								15		5	
2N5490	AP	S	N	50W	150	60	40	7A			20	100	2A				0.8							66	
2N5491	AP	S	N	50W	150	60	40	7A			20	100	2A				0.8							66	
2N5492	AP	S	N	50W	150	75	55	7A			20	100	2.5A				0.8							66	
2N5493	AP	S	N	50W	150	75	55	7A			20	100	2.5A				0.8							66	
2N5494	AP	S	N	50W	150	60	40	7A			20	100	3A				0.8							66	
2N5495	AP	S	N	50W	150	60	40	7A			20	100	3A				0.8							66	
2N5496	AP	S	N	50W	150	90	70	7A			20	100	3.5A				0.8							66	
2N5497	AP	S	N	50W	150	90	70	7A			20	100	3.5A				0.8							66	
2N5575	AP	S	N	300W	175	70	50	80A			10	40	60A				2							3	
2N5576	AP	S	N	300W	175	70	50	80A			10	40	60A				2							3	
2N5577			N	300W	175	70	50	80A			10	40	60A				2							3	
2N5578	AP	S	N	300W	175	90	70	60A			10	40	40A				2							3	
2N5579	AP		N	300W	175	90	70	60A			10	40	40A				2							3	
2N5580			N	300W	175	90	70	60A			10	40	40A				2							3	
2N5671	SHP	S	N	140W	200	120	90	30A	10mA	80	20	100	15A				50				900			3	
2N5672	SHP	S	N	140W	200	150	120	30A	10mA	80	20	100	15A				50				900			3	
2N5781	AP	S	P	10W	200	80	65	3.5A			20	100	1A	25										5	
2N5782	AP	S	P	10W	200	65	50	3.5A			20	100	1.2A	25										5	
2N5783	AP	S	P	10W	200	45	40	3.5A			20	100	1.6A	25										5	
2N5784	AP	S	N	10W	200	80	65	3.5A			20	100	1A	25										5	
2N5785	AP	S	N	10W	200	65	50	3.5A			20	100	1.2A	25										5	
2N5786	AP	S	N	10W	200	45	40	3.5A			20	100	1.6A	25										5	
2N5804	SP	S	N	110W	200	300	225	5A			10	100	5A	3										3	
2N5805	SP	S	N	110W	200	375	300	5A			10	100	5A	3										3	
2N5838	SP	S	N	100W	200	275	250	3A			8	40	3A											3	
2N5839	SP	S	N	100W	200	300	275	3A			10	50	2A											3	
2N5840	SP	S	N	100W	200	375	350	3A			10	50	2A											3	
2N5954	SP	S	P	40W	200	85	80	6A			20	100	3A				5							66	
2N5955	SP	S	P	40W	200	70	60	6A			20	100	2.5A				5							66	
2N5956	SP		P	40W	200	50	40	6A			20	100	2A				5							66	
2N6032	SP	S	N	140W	200	120	90	50A	10mA	80	10	50	50A				50				800			3	
2N6033	SP	S	N	140W	200	150	120	40A	10mA	80	10	50	40A				50				800			3	
2N6055	SP	S	N	100W	200	60	60	8A			100	18K	4A											3	DARLINGTON
2N6056	SP	S	N	100W	200	80	80	8A			100	18K	4A											3	DARLINGTON
2N6077	SHP	S	N	45W	200	300	275	7A			12	70	1.2A											66	
2N6078	SHP	S	N	45W	200	275	250	7A			12	70	1.2A											66	
2N6079	SHP	S	N	45W	200	375	350	7A			12	50	1.2A											66	
2N6098	AP	S	N	75W	150	70	60	10A			20	80	4A	15										220AA	
2N6099	AP	S	N	75W	150	70	60	10A			20	80	4A	15										220AB	
2N6100	AP	S	N	75W	150	80	70	10A			20	80	5A	15										220AA	
2N6101	AP	S	N	75W	150	80	70	10A			20	80	5A	15										220AB	
2N6102	AP	S	N	75W	150	45	40	16A			15	60	8A	15										220AA	
2N6103	AP	S	N	75W	150	45	40	16A			15	60	8A	15										220AB	
2N6106	AP	S	P	40W	150	80	70	7A			30	150	2A	20				10						220AA	
2N6107	AP	S	P	40W	150	80	70	7A			30	150	2A	20				10						220AB	
2N6108	AP	S	P	40W	150	60	50	7A			30	150	2.5A	20				10						220AA	
2N6109	AP	S	P	40W	150	60	50	7A			30	150	2.5A	20				10						220AB	
2N6110	AP	S	P	40W	150	40	30	7A			30	150	3A	20				10						220AA	
2N6111	AP	S	P	40W	150	40	30	7A			30	150	3A	20				10						220AB	
2N6175	SHP	S	N	20W	135	300	250	1A	50	240	30	190	20	25										5-P	

TYPE	TOSHIBA	NEC	HITACHI	MITSUBISHI	MATSUSHITA	FUJITSU	SONY	SANYO	NOTE
2N5321		2SD285							
2N5322	2SB502				2SB128				
2N5323	2SB502				2SB128				
2N5415	2SA739							2SB491-	
2N5416	2SA739							2SB491	
2N5490	2SC793	2SD217					2SD316		
2N5491	2SC793	2SD217					2SD316		
2N5492	2SC793	2SD217					2SD316		
2N5493	2SC793	2SD217					2SD316		
2N5 94	2SC793	2SD217					2SD316		
2N5495		2SD217					2SD338		
2N5496		2SD217					2SD338		
2N5497		2SD217					2SD338		
2N5575									
2N5576									
2N5577									
2N5578									
2N5579									
2N5580									
2N5671	2SC1435					2SC1301			
2N5672	2SC1435					2SC1301			
2N5781	2SB503				2SB128				
2N5782	2SB503				2SB128				
2N5783	2SB503				2SB128				
2N5784	2SD371	2SD155					2SD290		
2N5785	2SD371	2SD155					2SD290		
2N5786	2SD371	2SD155					2SD290		
2N5804							2SD262		
2N5805							2SC1348		
2N5838							2SD262		
2N5839							2SD262		
2N5840							2SC1348		
2N5954	2SB531						2SB518		
2N5955	2SB531						2SB518		
2N5956	2SB531						2SB518		
2N6032									
2N6033		2SD179							
2N6055									
2N6056									
2N6077							2SD262		
2N6078							2SD262		
2N6079							2SD262		
2N6098						2SD301			
2N6099						2SD301			
2N6100						2SD301			
2N6101						2SD301			
2N6102	2SC1080						2SD340		
2N6103	2SC1080						2SD340		
2N6106	2SA657	2SA648							
2N6107	2SA657	2SA648							
2N6108	2SA657	2SA648							
2N6109	2SA657	2SA648							
2N6110	2SA657	2SA648							
2N6111	2SA657	2SA648							
2N6175					2SD198	2SD1 9			

TYPE	USE	MATERIAL	POLARITY	MAXIMUM RATINGS						ELECTRICAL CHARACTERISTICS											OUTLINE TO.	NOTE			
				Pc 25°C (mW)	Tj (°C)	V _{as} (V)	V _{ceo} (V)	I _c (mA)	I _{oo}		h _{FE}			h _{FE}	h _{ie} (Ω)	h _{re} (×10)	h _{oe} (μS)	f _T *f _{ice} **f ₁₀₀ (MHz)	NF (dB)	C _{ob} (pF)			C _{orrb} (ps)		
2N6176	SHP	S	N	20W	135	350	300	1A	50	280	30	150	20	25										5-P	
2N6177	SHP	S	N	20W	135	450	350	1A	20	360	30	150	50	25										5-P	
2N6178	SHP	S	N	25W	150	100	75	2A	0.5	80	30	130	500					50						5-P	
2N6179	SHP	S	N	25W	150	75	50	2A	0.5	60	40	250	500					50						5-P	
2N6180	SHP	S	P	25W	150	100	75	2A	0.5	80	30	130	500					50						5-P	
2N6181	SHP	S	P	25W	150	75	50	2A	0.5	60	40	250	500					50						5-P	
2N6211	AP	S	P	35W	200	275	225	2A			10	100	1A											66	
2N6212	AP	S	P	35W	200	350	300	2A			10	100	1A											66	
2N6213	AP	S	P	35W	200	400	350	2A			10	100	1A											66	
2N6214	AP	S	P	20W	200	450	400	2A			10	100	1A											66	
2N6246	AP	S	P	125W	200	70	60	15A			20	100	7A					6						3	
2N6247	AP	S	P	125W	200	90	80	15A			20	100	6A					6						3	
2N6248	AP	S	P	125W	200	110	100	15A			20	100	5A					6						3	
2N6249	SP	S	N	175W	200	300	200	10A			10	50	10A											3	
2N6250	SP	S	N	175W	200	375	275	10A			8	50	10A											3	
2N6251	SP	S	N	175W	200	450	350	10A			6	50	10A											3	
2N6253	AP	S	N	115W	200	55	45	15A			20	70	3A											3	
2N6254	AP	S	N	150W	200	100	80	15A			20	70	5A											3	
2N6257	AP	S	N	150W	200	50	40	20A	4mA	50	15	75	8A											3	
2N6258	AP	S	N	250W	200	100	80	30A	1mA	100	20	60	15A											3	
2N6259	AP	S	N	250W	200	170	150	16A			15	60	8A											3	
2N6260	AP	S	N	29W	200	50	40	3A			20	100	1.5A											66	
2N6261	AP	S	N	50W	200	90	85	4A			25	100	1.5A											66	
2N6262	AP	S	N	150W	200	170	150	10A			20	70	3A											3	
2N6263	AP	S	N	20W	200	140	120	3A			20	100	500					0.8						66	
2N6264	AP	S	N	50W	200	170	150	3A			20	60	1A					0.8						66	
2N6288	SP	S	N	40W	150	40	30	7A			30	150	3A											220AB	
2N6289	SP	S	N	40W	150	40	30	7A			30	150	3A											220AA	
2N6290	SP	S	N	40W	150	60	50	7A			30	150	2.5A											220AB	
2N6291	SP	S	N	40W	150	60	50	7A			30	150	2.5A											220AA	
2N6292	SP	S	N	40W	150	80	70	7A			30	150	2A											220AB	
2N6293	SP	S	N	40W	150	80	70	7A			30	150	2A											220AA	
2N6354	SHP	S	N	140W	200	150	120	10A	5mA	150	20	150	5A											3	
2N6371	AP	S	N	117W	200	50	40	7A			15	60	8A	10				0.8						3	
2N6372	SP	S	N	40W	200	90	80	6A			20	100	2A					4						66	
2N6373	SP	S	N	40W	200	70	60	6A			20	100	2.5A											66	
2N6374	SP	S	N	40W	200	50	40	6A			20	100	3A					4						66	
2N6383	AP	S	N	100W	200	40	40	10A			10K	20K	5A	1K										3	DARLINGTON
2N6384	AP	S	N	100W	200	60	60	10A			10K	20K	5A	1K										3	DARLINGTON
2N6385	AP	S	N	100W	200	80	80	10A			10K	20K	5A	1K										3	DARLINGTON
2N6386	AP	S	N	40W	150	40	40	8A			10K	20K	3A	1K									200	220AB	DARLINGTON
2N6387	AP	S	N	40W	150	60	60	10A			10K	20K	5A	1K									200	220AB	DARLINGTON
2N6388	AP	S	N	40W	150	80	80	10A			10K	20K	5A	1K									200	220AB	DARLINGTON

TYPE	TOSHIBA	NEC	HITACHI	MITSUBISHI	MATSUSHITA	FUJITSU	SONY	SANYO	NOTE
2N6176					2SD198	2SD159			
2N6177							2SD171		
2N6178	2SC1079		2SC1055		2SC840				
2N6179	2SC1079		2SC1055		2SC840				
2N6180	2SA740	2SA616							
2N6181	2SA740	2SA616							
2N6211								2SB491	
2N6212	2SA739								
2N6213	2SA739								
2N6214	2SA739								
2N6246	2SA680								
2N6247	2SA679								
2N6248	2SA679								
2N6249	2SC1434								
2N6250	2SC1434								
2N6251	2SC1434								
2N6253	2SD113	2SD151				2SD250	2SD340		
2N6254	2SD113	2SD151				2SD250	2SD340		
2N6257	2SD113					2SD249			
2N6258	2SD113	2SD179							
2N6259		2SD179							
2N6260								2SD313	
2N6261						2SD175			
2N6262							2SD262		
2N6263			2SD126		2SD321				
2N6264			2SD126		2SD321				
2N6288		2SD322							
2N6289		2SD322							
2N6290		2SD322							
2N6291		2SD322							
2N6292		2SD322							
2N6293		2SD322							
2N6354							2SD262		
2N6371	2SD119					2SD249			
2N6372		2SD218					2SD88		
2N6373		2SD218					2SD88		
2N6374		2SD218					2SD88		
2N6383									
2N6384									
2N6385									
2N6386									
2N6387									
2N6388									

TYPE	USE	MATERIAL	POLARITY	MAXIMUM RATINGS					ELECTRICAL CHARACTERISTICS										OUTLINE TO	NOTE							
				Pc 25°C (mW)	Tj (°C)	Vas (V)	Vceo (V)	Ic (mA)	I _{ceo} (μA)	Vas(V)	min.	max.	Ic(mA)	hfe	hie (Ω)	hre (×10 ³)	h _{oe} (μS)	f _T #f _{ce} **f _{cb} (MHz)			NF (dB)	Cob (pF)	Coxh _b (ps)				
29	SHP	S	N	30W	150	40	40	3A				15	75	1A	20										220AB		
29A	SHP	S	N	30W	150	60	60	3A				15	75	1A	20											220AB	
29B	SHP	S	N	30W	150	80	80	3A				15	75	1A	20											220AB	
29C	SHP	S	N	30W	150	100	100	3A				15	75	1A	20											220AB	
30	SHP	S	P	30W	150	40	40	3A				15	75	1A	20											220AB	
30A	SHP	S	P	30W	150	60	60	3A				15	75	1A	20											220AB	
30B	SHP	S	P	30W	150	80	80	3A				15	75	1A	20											220AB	
30C	SHP	S	P	30W	150	100	100	3A				15	75	1A	20											220AB	
31	SHP	S	N	40W	150	40	40	5A				10	50	3A	20											220AB	
31A	SHP	S	N	40W	150	60	60	5A				10	50	3A	20											220AB	
31B	SHP	S	N	40W	150	80	80	5A				10	50	3A	20											220AB	
31C	SHP	S	N	40W	150	100	100	5A				10	50	3A	20											220AB	
32	SHP	S	P	40W	150	40	40	5A				10	50	3A	20											220AB	
32A	SHP	S	P	40W	150	60	60	5A				10	50	3A	20											220AB	
32B	SHP	S	P	40W	150	80	80	5A				10	50	3A	20											220AB	
32C	SHP	S	P	40W	150	100	100	5A				10	50	3A	20											220AB	
41	SHP	S	N	65W	150	40	40	7A				15	75	3A	20											220AB	
41A	SHP	S	N	65W	150	60	60	7A				15	75	3A	20											220AB	
41B	SHP	S	N	65W	150	80	80	7A				15	75	3A	20											220AB	
41C	SHP	S	N	65W	150	100	100	7A				15	75	3A	20											220AB	
42	SHP	S	P	65W	150	40	40	7A				15	75	3A	20											220AB	
42A	SHP	S	P	65W	150	60	60	7A				15	75	3A	20											220AB	
42B	SHP	S	P	65W	150	80	80	7A				15	75	3A	20											220AB	
42C	SHP	S	P	65W	150	100	100	7A				15	75	3A	20											220AB	
101	AP	S	P	75W	150	40	40	7A	100	40	25	150	2A													220AB	
102	AP	S	P	75W	150	60	60	7A	100	60	25	150	2A													220AB	
103	AP	S	P	75W	150	60	60	7A	100	60	30	150	1A													220AB	
104	AP	S	P	75W	150	80	80	7A	100	80	30	150	1A													220AB	
105	AP	S	P	65W	150	50	50	7A	100	50	25	100	2A													220AB	
201	AP	S	N	75W	150	40	40	7A	100	40	25	150	2A													220AB	
202	AP	S	N	75W	150	60	60	7A	100	60	25	150	2A													220AB	
203	AP	S	N	75W	150	60	60	7A	100	60	30	150	1A													220AB	
204	AP	S	N	75W	150	80	80	7A	100	80	30	150	1A													220AB	
205	AP	S	N	65W	150	50	50	7A	100	50	25	100	2A													220AB	
370	AP	S	P	40W	150	30	30	5A	100	30	25	1A														220AB	
371	AP	S	P	40W	150	40	40	5A	100	40	40	1A														220AB	
410	AP	S	N	125W	200	200	200	7A			30	90	1A					4								3	
411	AP	S	N	125W	200	300	300	7A			30	90	1A					2.5								3	
413	AP	S	N	125W	200	400	325	7A			20	80	500					4								3	
423	AP	S	N	125W	200	400	325	7A			30	90	1A					4								3	
431	AP	S	N	125W	200	400	325	7A			15	35	2.5A					4								3	
520	AP	S	N	40W	150	30	30	5A	100	30	25	1A														220AB	
521	AP	S	N	40W	150	40	40	5A	100	40	40	1A														220AB	
1000	AP	S	N	90W		60	60	8A			750	4A														3	DARLINGTON
1001	AP	S	N	90W		80	80	8A			750	4A														3	DARLINGTON
40022		G	P	12.5W		32					38							0.3								3	
40050		G	P	12.5W		40					50							0.5								3	
40051		G	P	12.5W		50					50							0.5								3	
40084	SH	S	N	1.8W	200	60	40	1A	0.25	30	50	250	150	5						1KHZ 8	15					18	
40250	AP	S	N	29W	200	50	50	4A	1mA	30	25	100	1.5A													66	
40250V1	AP	S	N	5.8W	200	50	50	4A	1mA	30	25	100	1.5A													66	
40251	AP	S	N	117W	200	50	50	15A	2mA	40	15	60	8A													3	
40254		G	P	12.5W		32					30							0.3								1	
40309	SP	S	N	5W	200	18		700	0.25	15	70	350	50					100								5	
40310	SP	S	N	29W	200	35		4A	10	15	20	120	1A					0.75								66	

TYPE	TOSHIBA	NEC	HITACHI	MITSUBISHI	MATSUSHITA	FUJITSU	SONY	SANYO	NOTE
29	2SD235				2SD226		2SD291		
29A	2SD234				2SD226A		2SD292		
29B	2SD102	2SD218				2SD148	2SD292		
29C	2SD102	2SD218				2SD148			
30					2SB513			2SB507	
30A					2SB513			2SB507	
30B	2SA739								
30C	2SA739								
31	2SD107						2SD88-I		
31A	2SD107						2SD88-I		
31B	2SD107						2SD88-I		
31C	2SD111	2SD218				2SD177	2SD88A-I		
32	2SA657	2SA648							
32A	2SA657	2SA648							
32B	2SA657	2SA648							
32C	2SA657	2SA648							
41	2SD119	2SD218	2SD125A			2SD116	2SD88A-I		
41A	2SD119	2SD218	2SD125A			2SD116	2SD88A-I		
41B	2SD119	2SD218	2SD125A			2SD116	2SD88A-I		
41C	2SD119	2SD218	2SD125A			2SD116	2SD88A-I		
42	2SA663	2SA648							
42A	2SA663	2SA648							
42B	2SA663	2SA648							
42C	2SA663	2SA648							
101	2SA663	2SA648							
102	2SA663	2SA648							
103	2SA663	2SA648							
104	2SA663	2SA648							
105									
201	2SD119	2SD218	2SD125A			2SD116	2SD88A-I		
202	2SD119	2SD218	2SD125A			2SD116	2SD88A-I		
203	2SD119	2SD218	2SD125A			2SD116	2SD88A-I		
204	2SD119	2SD218	2SD125A			2SD116	2SD88A-I		
205	2SD119	2SD218	2SD125A			2SD116	2SD88A-I		
370	2SA658	2SA627							
371	2SA658	2SA627							
410						2SC1229			
411						2SC1227			
413						2SC1230			
423						2SC1230			
431						2SC1230			
520	2SD107	2SD188					2SD338		
521		2SD188					2SD338		
1000									
1001									
40022									
40050									
40051									
40084			2SD120						
40250		2SD155			2SD226			2SD315	
40250V1		2SD155			2SD226			2SD315	
40251	2SD114	2SD151	2SD341			2SD250	2SD340		
40254									
40309			2SC1162	2SC1014	2SC1226				
40310		2SD155			2SD226			2SD315	

TYPE	USE	MATERIAL	POLARITY	MAXIMUM RATINGS					ELECTRICAL CHARACTERISTICS											OUTLINE TO.	NOTE				
				Pc 25°C (mW)	Tj (°C)	V _{DS} (V)	V _{CEO} (V)	I _C (mA)	f _{ceo}		h _{FE}		h _{FE}	h _{ie} (Ω)	h _{re} (×10 ³)	h _{oe} (μS)	f _T ***f _{ob} (MHz)	NF (dB)	C _{ob} (pF)			C _{oib} (ps)			
									(μA)	V _{CE} (V)	min.	max.											I _C (mA)		
40311	SP	S	N	5W	200	30	700	0.25	15	70	350	50					100					5			
40312	SP	S	N	29W	200	60	4A	10	15	20	120	1A					0.75						66		
40313	SP	S	N	35W	200	300	2A			40	250	100											66		
40314	SP	S	N	5W	200	40	700	0.25	15	70	350	50					100						5		
40315	SP	S	N	5W	200	35	700	0.25	15	70	350	50					100						5		
40316	SP	S	N	29W	200	40	4A	10	15	20	120	1A					0.75						66		
40317	SP	S	N	5W	200	40	700	0.25	15	40	200	10											5		
40318	SP	S	N	35W	200	300	2A			50		500											66		
40319	SP	S	P	5W	200	40	700	0.25	15	35	200	50					100						5		
40320	SP	S	N	5W	200	40	700	0.25	15	40	200	10											5		
40321	SP	S	N	5W	200	300	1A				25	200	20										5		
40322	SP	S	N	35W	200	300	2A				75		500										66		
40323	SP	S	N	5W	200	10	700	0.25	15	70	350	50					100						5		
40324	SP	S	N	29W	200	35	4A	10	15	20	120	1A					0.75						66		
40325	SP	S	N	117W	200	35	15A	5mA	30	12	60	8A											3		
40326	SP	S	N	5W	200	40	700	0.25	15	40	200	10											5		
40327	SP	S	N	5W	200	300	1A				40	250	20										5		
40328	SP	S	N	35W	200	300	2A				40		20										66		
40346	SP	S	N	10W	200	175	1A				25		10										5		
40346V1	SP	S	N	10W	200	175	1A				25		10										5		
40346V2	SP	S	N	4W	200	175	1A				25		10										5		
40347	AP	S	N	8.75W	200	60	40	1.5A			25	100	450										5		
40347V1	AP	S	N	4.4W	200	60	40	1.5A			25	100	450										5		
40347V2	AP	S	N	11.7W	200	60	40	1.5A			25	100	450										5		
40348	AP	S	N	8.75W	200	90	65	1.5A			30	125	300										5		
40348V1	AP	S	N	4.4W	200	90	65	1.5A			30	125	300										5		
40348V2	AP	S	N	11.7W	200	90	65	1.5A			30	125	300										5		
40349	AP	S	N	8.75W	200	160	140	1.5A			30	125	150										5		
40349V1	AP	S	N	4.4W	200	160	140	1.5A			30	125	150										5		
40349V2	AP	S	N	11.7W	200	160	140	1.5A			30	125	150										5		
40360	SP	S	N	5W	200	70	700				40	200	10					100					5		
40361	SP	S	N	5W	200	70	700				70	350	50					100					5		
40362	SP	S	P	5W	200	70	700				35	200	50					100					5		
40363	SP	S	N	115W	200	70	15A				20	70	4A					0.7					3		
40364	SP	S	N	35W	200	60	7A				35	175	500					15					66		
40366			N	5W	200	120	65	1A	2nA	60	40	120	150										5		
40367			N	5W	200	100	55	1.5A	4	30	35	100	200										5		
40368			N	25W	200	100	55	3A	9	30	35	100	750										8		
40369			N	75W	200	100	55	6A	10	30	25	75	1.5A										3		
40372	AP	S	N	25W	200	90	55	4A			25	100	500										66		
40373	AP	S	N	25W	200	160	140	3A			25	100	500					0.8					66		
40374	AHP	S	N	5.8W	200	250	175	2A			40		100										66		
40375	SP	S	N	5.8W	200	120	50	7A	5mA	40	50	200	500	6								175	66		
40385			N	5W	200	450	350	1A			40	160	20										5		
40389	SH	S	N	3.5W	200	60	700	0.25	30	50	250	150											5		
40390	AH	S	N	3.5W	200	300	250	1A			40	160	20										10	66	
40391	AP	S	P	3.5W	200	60	40	1A	0.25	30	50	250	150										5		
40392	SH	S	N	7W	200	60	700	0.25	30	50	250	150										15	5		
40394	AP	S	P	7W	200	60	40	1A	0.25	30	50	250	150										5		
40406	SH	S	P	1W	200	50	700				30	200	0.1					100					5		
40407	SH	S	N	1W	200	50	700	0.25	10	40	200	1						100				15	5		
40408	SH	S	N	1W	200	90	700				40	200	10					100					5		
40409	SH	S	N	3W	200	90	700				50	250	150					100					5		
40410	SH	S	P	3W	200	90	700				50	250	150					100					5		
40411	SHP	S	N	150W	200	90	30A				35	100	4A					0.8					3		

TYPE	TOSHIBA	NEC	HITACHI	mitsubishi	MATSUSHITA	FUJITSU	SONY	SANYO	NOTE
40311	2SC1173	2SC204	2SD120	2SC1014	2SC1226				
40312		2SD155			2SD226A				
40313	2SC1433					2SC1463			
40314	2SC1173	2SC204	2SD120	2SC1014	2SC1226				
40315	2SC1173		2SD120	2SC1014	2SC1226				
40316		2SD155			2SD226A				
40317	2SC1173	2SC204		2SC1014	2SC1226				
40318	2SC1433					2SC1463			
40319				2SA624			2SA761		
40320	2SC1173	2SC204		2SC1014	2SC1226				
40321	2SC782				2SD198	2SD159			
40322	2SC1433					2SC1463			
40323	2SC1173	2SC204		2SC1014	2SC1226				
40324		2SD155			2SD226A				
40325		2SD151	2SD341			2SD250	2SD340		
40326	2SC1173	2SC204		2SC1014	2SC1226				
40327					2SD198	2SD159			
40328	2SC1433					2SC1463			
40346						2SD251			
40346V1						2SD251			
40346V2						2SD251			
40347	2SD234			2SD361			2SD292		
40347V1	2SD234			2SD361			2SD292		
40347V2	2SD234			2SD361			2SD292		
40348			2SD121		2SD226B	2SD185	2SD292		
40348V1			2SD121		2SD226B	2SD185	2SD292		
40348V2			2SD121		2SD226B	2SD185	2SD292		
40349						2SD251			
40349V1						2SD251			
40349V2						2SD251			
40360	2SC1173	2SC204		2SC1155					
40361	2SC1173	2SC204		2SC1155					
40362							2SA761		
40363		2SD181	2SD341			2SD250	2SD340		
40364			2SC1055						
40366	2SC782		2SD121			2SC1031			
40367	2SC782		2SD121			2SC1031			
40368	2SD102				2SD334				
40369	2SD111				2SD334				
40372	2SD102				2SD334				
40373					2SD334				
40374					2SD198				
40375									
40385	2SC1171	2SC1101	2SC1174	2SC1153					
40389		2SD79	2SD121	2SD356		2SD185			
40390					2SD198	2SD159			
40391				2SB524					
40392	2SD234			2SD361			2SD292		
40394				2SB524					
40406		2SA607			2SA752				
40407	2SC512	2SC959	2SC1212A		2SC1407				
40408	2SC1381							2SC614	
40409	2SC511	2SC1266		2SC448		2SC1069			
40410							2SA761		
40411	2SD114	2SD132	2SD341			2SD250	2SD340		

TYPE	USE	MATERIAL	POLARITY	MAXIMUM RATINGS						ELECTRICAL CHARACTERISTICS											OUTLINE TO.	NOTE		
				Pc 25°C (mW)	Tj (°C)	Vas (V)	Vceo (V)	Ic (mA)	I _{co}		h _{re}			h _{fe}	h _{ie} (Ω)	h _{re} (×10)	hoe (μS)	f _T #f _{ce} #f _{cb} (MHz)	NF (dB)	Cob (pF)			Covbb (ps)	
									(μA)	Vas(V)	min.	max.	Ic(mA)											
40412	SP	S	N	10W	200	250		1A			40		30									5		
40412V1	SP	S	N	4W	200	250		1A			40		30										5	
40412V2	SP	S	N	10W	200	250		1A			40		30										5	
40421		G	P	12.5W		75					62	175					2						3	
40439		G	P	5W		320																	3	
40440		G	P	5W		200																	3	
40462		G	P	12.5W		40											0.6						3	
40484		S	N	25W		55					50												8	
40513	AP	S	N	83W	150	45		6A			25	100	3A										219AB	
40514	AP	S	N	83W	150	45		6A			25	100	3A										219AA	
40537	SH	S	P	5W		55	700				50	300	50				100						5	
40538	SH	S	P	5W		55	700				15	90	500				100						5	
40539	AH	S	N	5W		55	700				15	90	500				100						5	
40542	AH	S	N	83W		50		6A			20	70	2.5A									2.8	3	
40543	AH	S	N	83W		60		8A			20	70	3A									2.8	3	
40544	AH	S	N	7W		50		700			35	200	50				100						5	
40546		S		8W							50						25						66	
40594	AP	S	N	10W		95		2A			70	350	300										5	
40595	AP	S	P	10W		95		2A			70	350	300										5	
40611	AP	S	N	5W		25	700	0.5	15		70	500	50										5	
40612	AP	G	P	12.5W		25	5A	3	30	30	150	1A											3	
40613	AP	S	N	36W		25	4A	2	25	30	120	1A											66	
40616	AP	S	N	5W		32	700	0.5	15	70	100	50											5	
40618	AP	S	N	36W		30	4A	2	30	30	120	1A											66	
40621	AP	S	N	36W		32	4A	0.5	30	25	100	1.5A											66	
40622	AP	S	N	36W		40	4A				25	100	1.5A										66	
40623	AP	G	P	12.5W		45	5A	500	30	50	170	1A											3	
40624	AP	S	N	50W		45	6A				20	100	2.5A										66	
40625	AP	S	N	3.5W		45	1A	0.25	60	100	300	150											5	
40626	AP	G	P	12.5W		55	5A	500	30	50	170	1A											3	
40627	AP	S	N	50W		55	6A				20	100	2.5A										66	
40628	AP	S	N	3.5W		55	1A	0.25	60	100	300	150											5	
40629	AP	S	N	36W		35	4A				20	70	1A										66	
40630	AP	S	N	36W		40	4A				20	70	1.5A										66	
40631	AP	S	N	36W		45	4A				20	70	2A										66	
40632	AP	S	N	50W		60	6A				20	70	3A										66	
40633	AP	S	N	83W		75	8A				20	70	4A										3	
40634	AP	S	P	5W		75	700				50	250	150										5	
40635	AP	S	N	5W		75	700				50	250	150										5	
40636	AP	S	N	115W		95	15A				20	70	4A										3	
40637		S	N	1W		30											300						52	
40850	AP	S	N	35W		450	300	2A			25	750											66	
40851	AP	S	N	45W		450	350	7A			12	1.2A											66	
40852	AP	S	N	100W		450	350	7A			12	1.2A											3	
40853	AP	S	N	100W		450	300	10A			10	5A											3	
40854	AP	S	N	110W		450	300	15A			10	10A											3	
40885	SHP	S	N	20W	135	300	250	1A	50	240	30	190	20	25										
40886	SHP	S	N	20W	135	350	300	1A	50	280	30	150	20	25										
40887	SHP	S	N	20W	135	450	350	1A	20	360	30	150	50	25										
40910	AP	S	N	29W	200	50	40	3A			20	100	1.5A										66	
40911	AP	S	N	50W	200	90	85	4A			25	100	1.5A										66	
40912	AP	S	N	20W	200	140	120	3A			20	100	500										66	
40913	AP	S	N	50W	200	170	150	3A			20	60	1A				0.8						66	
45190	AP	S	N	40W	150	40	40	7A	100	40	25	100	1.5A				2						220AB	
45191	AP	S	N	40W	150	60	60	7A	100	60	25	100	1.5A				2						220AB	

TYPE	TOSHIBA	NEC	HITACHI	mitsubishi	MATSUSHITA	FUJITSU	SONY	SANYO	NOTE
40412					2SD198	2SD159			
40412V1					2SD198	2SD159			
40412V2					2SD198	2SD159			
40421									
40439									
40440									
40462									
40484									
40513	2SD111	2SD323	2SD125			2SD196	2SD88		
40514	2SD111	2SD323	2SD125			2SD196	2SD88		
40537	2SA597			2SA645			2SA761		
40538	2SA597			2SA645			2SA761		
40539	2SC547	2SC1160			2SC1155				
40542	2SD111	2SD322					2SD339		
40543	2SD111	2SD322					2SD339		
40544		2SC1160	2SC819	2SC1155		2SC798			
40546									
40594		2SD285					2SC756		
40595	2SB502								
40611		2SC1333		2SC1355					
40612			2SB337		2SB128			2SB407	
40613		2SD188			2SD189		2SD338	2SD315	
40616		2SC1160		2SC1155					
40618		2SD188					2SD338		
40621		2SD188					2SD338		
40622		2SD188					2SD338		
40623			2SB337	2SB138	2SB128			2SB407	
40624		2SD188					2SD338		
40625		2SC1098		2SC1014					
40626			2SB337		2SB128			2SB407	
40627		2SD188		2SC1314			2SD338		
40628		2SC1098		2SC1014					
40629		2SD188		2SC1314	2SC189		2SD338		
40630		2SD188		2SC1314	2SC189		2SD338		
40631		2SD188		2SC1314	2SC189		2SD338		
40632		2SD188			2SC189		2SD338		
40633							2SD339		
40634							2SA761		
40635		2SC1160							
40636	2SD111	2SD151				2SD250	2SD340		
40637									
40850	2SC1433								
40851	2SC1433								
40852	2SC1434								
40853	2SC1434								
40854	2SC1434								
40855					2SD198				
40886	2SC1433								
40887	2SC1433								
40910		2SD335							
40911							2SD338		
40912	2SD110	2SD297					2SD45		
40913			2SD126		2SD321		2SD45		
45990		2SD322					2SD316		
45191		2SD322					2SD316		

GENERAL ELECTRIC

TYPE	MATERIAL	POLARITY	MAXIMUM RATINGS					ELECTRICAL CHARACTERISTICS										OUTLINE TO:	NOTE							
			Pc 25°C (mW)	Tj (°C)	Vce (V)	Vceo (V)	Ic (mA)	Icso (μA)	Vce(V)	min.	max.	Ic(mA)	hfe	hie (Ω)	hre (×10 ³)	hoe (μS)	f _T (MHz)			NF (dB)	Cob (pF)	t _{0.1} (ps)				
2N34	A	G	P	50		25																				
2N34A	A	G	P	50		25																				
2N36	A	G	P	50	50	20																				
2N37	A	G	P	50	20																					
2N38	A	G	P	50																						
2N38A	A	G	P	50	20	20																				
2N41	A	G	P	50		25																				
2N43	A	G	P	240	85	45	30					34			20	30							500			GE
2N43A	A	G	P	240	85	45	30					34	65		20	30							500			GE
2N44	A	G	P	240	85	45	30					18	43		20								500			GE
2N44A	A	G	P	240	85	45	30					18	43		20								500			GE
2N46	A	G	P	50		25																				
2N47	A	G	P	50		35																				
2N48	A	G	P	50		35																				
2N49	A	G	P	50		35																				
2N54	A	G	P	200	60	45																				
2N55	A	G	P	200	60	45																				
2N56	A	G	P	200		60	45																			
2N59	A	G	P	180	85	25	25																			
2N59A	A	G	P	180	85	40	40																			
2N60	A	G	P	180	85	25	25																			
2N60A	A	G	P	180	85	40	40																			
2N60B	A	G	P	180	85	50	50																			
2N60C	A	G	P	180	85	50	60																			
2N61	A	G	P	180	85	25	25																			
2N61A	A	G	P	180	85	40	40																			
2N61B	A	G	P	180	85	50	50																			
2N61C	A	G	P	180	85	60	60																			
2N63	A	G	P	102	85	44	44																			
2N64	A	G	P	102	85	30	30																			
2N65	A	G	P		85	24	24																			
2N73	SC	G	P	200			50																			
2N74	S	G	P	200			50																			
2N75	S	G	P	200			20																			
2N76	A	G	P	5 W	60	20																	500			
2N77	A	G	P	35		25																				
2N79	A	G	P	35		35																				
2N80	A	G	P	50		25																				
2N81	A	G	P	50	100		20									20										
2N82	A	G	P	35	71	20						20	60		1											
2N96	A	G	P	50		30																	500			
2N104	A	G	P	150	70	30																				
2N105	A	G	P	35	50	35																				
2N106	A	G	P	102	85	6																				
2N108	A	G	P	50																						
2N109	A	G	P	165	71	35	25					65	115		50	50										
2N122	AP	S	N	8.7 W	150	120						3			100											
2N130	A	G	P	85	85	44																				
2N130A	A	G	P	100	85	45	40																			
2N131	A	G	P	85	30																					
2N131A	A	G	P	100	85	45	30																			
2N132	A	G	P	85	85	24																				
2N132A	A	G	P	100	85	35	20																			
2N133	A	G	P	85	85	30																				
2N133A	A	G	P	100	85	35	20																			

TYPE	TOSHIBA	NEC	HITACHI	mitsubishi	MATSUSHITA	FUJITSU	SONY	SANYO	NOTE
2N34	2SB56		2SB77		2SB172				
2N34A	2SB54		2SB75		2SB172				
2N36									
2N37									
2N38									
2N38A									
2N41								(沖)	
2N43	2SB415	2SB224		2SB458A	2SB178A			2SB198	
2N43A	2SB415	2SB224		2SB458A	2SB178A			2SB198	
2N44	2SB415	2SB224	2SB156A	2SB458A	2SB178A			2SB198	
2N44A	2SB55	2SB224	2SB75A	2SB458A	2SB178A			2SB198	
2N46									
2N47									
2N48									
2N49									
2N54									
2N55									
2N56				2SB454					
2N59	2SB415	2SB223	2SB370A		2SB324				
2N59A	2SB415	2SB224	2SB370A	2SB454	2SB324				
2N60	2SB415	2SB223	2SB370A		2SB324				
2N60A	2SB415	2SB224	2SB370A		2SB324				
2N60B									
2N60C									
2N61	2SB415	2SB223			2SB324				
2N61A	2SB415	2SB223			2SB324				
2N61B					2SB177				
2N61C					2SB177				
2N63	2SB56		2SB75A		2SB177				
2N64	2SB56		2SB75A		2SB177				
2N65	2SB56		2SB75A		2SB175				
2N73				2SB454					
2N74				2SB454					
2N75									
2N76									
2N77	2SB54		2SB75		2SB175			2SB185	
2N79									
2N80									
2N81									
2N82									
2N96									
2N104	2SB55		2SB75A		2SB175			2SB185	
2N105	2SB55		2SB75A		2SB175			2SB185	
2N106	2SB440		2SB73	2SB134			2SB382		
2N108									
2N109	2SB56A		2SB77A	2SB135	2SB172			2SB185	
2N122		2SB241A							
2N130	2SB56A		2SB75A		2SB177				
2N130A	2SB56A		2SB75A		2SB177				
2N131	2SB56A		2SB75A		2SB177				
2N131A	2SB56A		2SB75A		2SB177				
2N132	2SB54		2SB75A	2SB135	2SB173			2SB185	
2N132A	2SB56A		2SB75A		2SB177				
2N133	2SB56A		2SB75A	2SB135	2SB177				
2N133A	2SB56A		2SB75A		2SB177				

GE

TYPE	USE	MATERIAL	POLARITY	MAXIMUM RATINGS					ELECTRICAL CHARACTERISTICS											OUTLINE TO.	NOTE							
				Pc 25°C (mW)	Tj (°C)	Vas (V)	Vas (V)	Ic (mA)	I _{load} (μA)	V _{ce} (V)	h _{FE}		h _{FE}	h _{ie} (Ω)	h _{re} (×10 ⁻⁴)	h _{oe} (μS)	f _T f _α f _β f _β f _α (MHz)	NF (dB)	Cob (pF)			C _{ext} (ps)						
2N138	A	G	P	50	50	24																						
2N138A	A	G	P	150	85	45	30				10		50															
2N139	A	G	P	80	70	16																						
2N140	A	G	P	80	70	16																						
2N175	AH	G	P	50	71	10																						
2N180	A	G	P	150	75	30																						
2N181	A	G	P	250	75	30																						
2N185	A	G	P	150	50	20																						
2N206	A	G	P	75		30																						
2N207	A	G	P	50	65	12	12																					
2N207A	A	G	P	50	65	12	12																					
2N207B	A	G	P	50	65	12	12																					
2N217	A	G	P	150	71	35	25																					
2N220	A	G	P	50	71	10					65	115	50															
2N223	A	G	P	100	65		18																					
2N224	A	G	P	250	75	25																						
2N225	A	G	P	250	75	25					60	120	100															
2N226	A	G	P	250	75	30																						
2N227	A	G	P	250	75	30					35	105	100															
2N237	A	G	P	150	55	45																						
2N238	A	G	P	50	60	20																						
2N265	A	G	P	75	85		25																					
2N270	A	G	P	150	50	25																						
2N272	A	G	P	150	85	30	10																					
2N273	A	G	P	150	85	45	25				30		50															
2N281	A	G	P	167	75	16																						
2N291	A	G	P	180	50	15					120																	
2N319	A	G	P	225	85		20																					GE
2N320	A	G	P	225	85		20																					GE
2N321	A	G	P	225	85		20																					GE
2N322	A	G	P	140	60	18	18																					GE
2N323	A	G	P	140	60	18	18																					GE
2N324	A	G	P	140	60	18	18																					GE
2N331	A	G	P	200	71	30																						
2N343A	A	S	N	1W	150	60	60																					
2N359	A	G	P	170	85	25	18																					
2N360	A	G	P	170	85	32	30				100	300	50															
2N361	A	G	P	170	85	32	30				50	150	50															
2N362	A	G	P	170	85	25	18																					
2N363	A	G	P	170	85	32	28																					
2N367	S	G	P	100	75	30																						
2N368	S	G	P	100	75	30																						
2N369	S	G	P	100	75	30																						
2N381	A	G	P	200	100	50	25																					
2N382	A	G	P	200	100	50	25																					
2N383	A	G	P	200	100	50	25																					
2N398	SP	G	P	50	55	105	105																					
2N398A	A	G	P	150	100	105	105																					
2N402	A	G	P	180	85	25	20																					
2N403	A	G	P	180	85	25	20																					
2N404A	S	G	P	150	100	40	35																					GE
2N405	A	G	P	150	71	20																						
2N406	A	G	P	150	71	20																						
2N407	A	G	P	150	71	20																						
2N408	A	G	P	150	71	20																						

TYPE	TOSHIBA	NEC	HITACHI	MITSUBISHI	MATSUSHITA	FUJITSU	SONY	SANYO	NOTE
2N138	2SB56A		2SB77 A	2SB136					
2N138A									
2N139									
2N140									
2N175	2SB56		2SB73	2SB134			2SB380		
2N180	2SB56A		2SB77 A	2SB136	2SB172				
2N181	2SB56A		2SB89 A						
2N185	2SB56A		2SB77 A	2SB136	2SB172				
2N206	2SB94		2SB75 A	2SB135	2SB173				
2N207	2SB94		2SB75 A	2SB135	2SB173				
2N207A	2SB94		2SB75 A	2SB135	2SB173				
2N207B	2SB94		2SB75 A	2SB135	2SB173				
2N217	2SB56A								
2N220	2SB439			2SB134			2SB378		
2N223	2SB56A		2SB156 A	2SB495	2SB324				
2N224	2SB421		2SA555	2SB495	2SB324				
2N225	2SB421		2SA555	2SB495	2SB324				
2N226	2SB421		2SA555		2SB324				
2N227	2SB421		2SA555		2SB324				
2N237	2SB55	2SB224	2SB77A	2SB136A					
2N238	2SB56		2SB77 A	2SB136					
2N265	2SB94		2SB75 A	2SB135	2SB171				
2N270	2SB415		2SB156 A	2SB495	2SB324				
2N272	2SB56 A		2SB77	2SB136					
2N273	2SB53		2SB75 A	2SB136	2SB177				
2N281	2SB56	2SB 164	2SB77 A	2SB136					
2N291	2SB421	2SB 164	2SB156 A	2SB495	2SB324				
2N319	2SB421	2SB 164		2SB495	2SB324				
2N320	2SB421	2SB 164		2SB495	2SB324				
2N321	2SB421			2SB495	2SB324				
2N322	2SB421		2SB156 A	2SB495	2SB324				
2N323	2SB421		2SB156 A	2SB495	2SB324				
2N324	2SB421		2SB156 A	2SB495	2SB324				
2N331	2SB53								
2N343A									
2N359									
2N360	2SB421			2SB495	2SB324				
2N361	2SB421			2SB495	2SB324				
2N362	2SB56A		2SB77	2SB136					
2N363	2SB56A		2SB77A	2SB136					
2N367	2SB56A		2SB77 A	2SB135					
2N368	2SB56A		2SB77 A						
2N369	2SB56A		2SB77 A	2SB135					
2N381	2SB421				2SB324				
2N382	2SB421				2SB324				
2N383	2SB421				2SB324				
2N398									
2N398A									
2N402	2SB365	2SB223	2SB370 A	2SB457A	2SB324				
2N403	2SB365	2SB223	2SB370 A	2SB457A	2SB324				
2N404A									
2N405	2SB94		2SB77	2SB135	2SB173				
2N406	2SB94		2SB77	2SB135	2SB173				
2N407	2SB56A		2SB77	2SB136					
2N408	2SB56A		2SB77	2SB136					

TYPE	USE	MATERIAL	POLARITY	MAXIMUM RATINGS							ELECTRICAL CHARACTERISTICS										OUTLINE TO-	NOTE
				Pc 25°C (mW)	Tj (°C)	Vas (V)	Vas0 (V)	Ic (mA)	Iao (μA)		hFE		hfe	hie (Ω)	hre (x10)	hoe (μΩ)	ft	NF (dB)	Cob (pF)	Cokrb (ps)		
									min.	max.	min.	max.										
2N460	A	G	P	200	100	45				16	32											
2N461	A	G	P	200	100	45				32	100											
2N462	S	G	P	150	75	40				20		200					500					
2N464	A	G	P	150	85	45	40															
2N465	A	G	P	150	85	45	30															
2N466	A	G	P	150	85	35	20															
2N467	A	G	P	150	85	35	15															
2N497	A	S	N	4 W	200	60	60			12	36	200										
2N497A	A	S	N	5 W	200	60	60			12	36	200										
2N498	A	S	N	4 W	200	100	100			12	36	200										
2N505		G	P																			
2N506	A	G	P	50	85	40				25	50	50					500					
2N508	A	G	P	200	100	18	18	200	4	16	99	198	20	110	28	7	0.4	2.5	¹ 1KHZ	18	5	GE
2N508A	A	G	P	200	100	30	30	200	4	25	100	200	20	75	26	7	0.4	2.5	¹ 1KHZ	18	5	GE
2N524	A	G	P	225	100	45	30	500	35	30	25	42	20	18	26	1	0.1	800	¹ 1KHZ	18	5	GE
2N525	A	G	P	225	100	45	30	500	50	30	34	65	20	30	26	1	0.1	1	¹ 1KHZ	18	5	GE
2N526	A	G	P	225	100	45	30	500	70	30	53	90	20	44	26	1	0.1	1.3	¹ 1KHZ	18	5	GE
2N527	A	G	P	225	100	45	30	500	95	30	72	121	20	60	26	1	0.1	1.5	¹ 1KHZ	18	5	GE
2N534	A	G	P	25	65	50	50							35								
2N535	A	G	P	50	85	20	20							35								
2N535A	A	G	P	50	85	20	20							35								
2N535B	A	G	P	50	85	20	20							35								
2N536	S	G	P	50	85	20	20			100		30										
2N563	S	G	P	150	85	30	25			10	30											
2N564	S	G	P	120	85	30	25			10	30											
2N565	S	G	P	150	85	30	25			30	50											
2N566	S	G	P	120	85	30	25			30	50											
2N567	S	G	P	150	85	30	25			50	70											
2N568	S	G	P	120	85	30	25			50	70											
2N570	S	G	P	120	85	30	20			70	100											
2N571	S	G	P	150	85	30	10			100												
2N572	S	G	P	120	85	30	10			100												
2N586	S	G	P	250	85	45				35		250										
2N591	A	G	P	50	71	32	32															
2N592	S	G	P	125	85	20	20			20												
2N593	S	G	P	125	85	40	30			30												
2N597	S	G	P	250	100	45	40			40		100					3					
2N599	S	G	P	250	100	30	20			100		100					10					
2N609	A	G	P	180	85	25	15															
2N610	A	G	P	180	85	25	15															
2N611	A	G	P	180	85	25	15															
2N612	A	G	P	180	85	25	15															
2N613	A	G	P	180	85	25	15															
2N631	A	G	P	167	85	25	20															
2N632	A	G	P	167	85	36	20															
2N633	A	G	P	167	85	35	30															
2N650	A	G	P	200	100	45	30			30		10	30				0.75					
2N650A	A	G	P	200	100	45	30			33		10	30				0.75					
2N651	A	G	P	200	100	45	30			45		10	50				1					
2N652	A	G	P	200	100	45	30			80		10	100									
2N652A	A	G	P	200	100	45	30			80		10	100									
2N653	A	G	P	200	100	30	25			20		10	30									

TYPE	TOSHIBA	NEC	HITACHI	mitsubishi	MATSUSHITA	FUJITSU	SONY	SANYO	NOTE
2N460	2SB415		2SB537	2SB454	2SB281				
2N461	2SB415		2SB537	2SB454	2SB281				
2N462									
2N464	2SB56 A		2SB77 A		2SB172				
2N465	2SB56 A		2SB77 A		2SB172				
2N466	2SB56 A		2SB77 A		2SB172				
2N467	2SB56 A		2SB77 A		2SB172				
2N497	2SC547			2SC976		2SC866		2SC614	
2N497 A	2SC547			2SC976		2SC866		2SC614	
2N498	2SC514		2SC685					2SC614	
2N505									
2N506	2SB54		2SB75 A		2SB177				
2N508	2SB415	2SB226	2SB156A		2SB324				
2N508A	2SB415	2SB226			2SB324				
2N524	2SB421	2SB226			2SB324				
2N525	2SB421	2SB226			2SB324				
2N526	2SB421	2SB226			2SB324				
2N527	2SB421	2SB226			2SB324				
2N534	2SB55		2SB75 A		2SB177				
2N535	2SB54		2SB75		2SB173			2SB186	
2N535A	2SB54		2SB75		2SB173			2SB186	
2N535B	2SB54		2SB75		2SB173			2SB186	
2N536	2SB54		2SB75					2SB186	
2N563	2SB56 A		2SB77 A		2SB172			2SB187	
2N564	2SB56 A		2SB77 A		2SB172			2SB187	
2N565	2SB56 A		2SB77 A		2SB172			2SB187	
2N566	2SB56 A		2SB77 A		2SB172			2SB187	
2N567	2SB56 A		2SB77 A		2SB172			2SB187	
2N568	2SB56 A		2SB77 A		2SB172			2SB187	
2N570	2SB56 A		2SB77 A		2SB172			2SB187	
2N571									
2N572									
2N586									
2N591	2SB54		2SB75 A	2SB135	2SB172				
2N592									
2N593									
2N597									
2N599									
2N609	2SB364	2SB223	2SB370	2SB457 A	2SB324				
2N610	2SB364	2SB223	2SB370	2SB457 A	2SB324				
2N611	2SB364	2SB223	2SB370	2SB457 A	2SB324				
2N612	2SB364	2SB223	2SB370	2SB457 A	2SB324				
2N613	2SB364	2SB223	2SB370	2SB457 A	2SB324				
2N631	2SB56		2SB77		2SB172				
2N632	2SB56 A		2SB77		2SB172				
2N633	2SB56 A		2SB77 A		2SB172				
2N650	2SB415		2SB156A		2SB402				
2N650A	2SB415		2SB156A		2SB402				
2N651	2SB415		2SB156A		2SB402				
2N652	2SB415		2SB156A		2SB402				
2N652A	2SB415		2SB156A		2SB402				
2N653	2SB415		2SB156A		2SB324				

TYPE	USE	MATERIAL	POLARITY	MAXIMUM RATINGS				ELECTRICAL CHARACTERISTICS												OUTLINE TO:	NOTE		
				Pc 25°C (mW)	Tj (°C)	V _{ce} (V)	V _{ce0} (V)	I _c (mA)	I _{ceo} (μ A)		I _{RE}		h _{FE}	h _{ie}	h _{ie} (Ω)	h _{re} ($\times 10^{-4}$)	h _{oe} (μS)	f _T * * * * (MHz)	NF (dB)			C _{ob} (pF)	C _{omb} (ps)
2N654	A	G	P	200	100	30	25			40		10	50										
2N655	A	G	P	200	100	30	25			70		10	100										
2N656	A	S	N	4W	200	60	60			30	90	200											
2N656A	A	S	N	5W	200	60	60			30	90	200											
2N657	A	S	N	4W	200	100	100			30	90	200											
2N680	A	G	P	150	75	20	20			18	165	50					15						
2N696A	S	S	N	800	300	60	35			20	60	150	15				40						
2N697	S	S	N	600	175	60	40			40	120	150	15				40						
2N697A	S	S	N	800	300	60	35			40	120	150	25				50						
2N698	S	S	N	800	200	120	80			20	60	150	15				40						
2N699	S	S	N	600	175	120	80			40	120	150	35				50						
2N702	SH	S	N	300	175	25	25			20	60	10					70						
2N703	SH	S	N	300	175	25	25			40	100	10					70						
2N705	SH	G	P	300	100	15	15			25		10											
2N706	SH	S	N	300	175	25	20			20		10					200						
2N706A	SH	S	N	300	175	25	20			20	60	10					200						
2N706B	SH	S	N	300	175	25	15			20	60	10					200						
2N708	SH	S	N	360	200	40	20			30	120	10					300						
2N718	AH	S	N	400	175	60	40			40	120	150					50						
2N718A	AH	S	N	500	200	75	50			40	120	150	30				60						
2N728	SH	S	N	4W	175	15	15			20	200	10					100						
2N729	SH	S	N	4W	175	30	30			20	200	10					100						
2N753	SH	S	N	300	175		20			40	120	10					200						
2N759	A	S	N	500	200	45	45						36				50						
2N760	A	S	N	500	200	45	45						76				50						
2N869	AH	S	N	360	200	45	18			20	120	10					100						
2N911	A	S	N	500	200	100	80			35		10	36				50						
2N912	A	S	N	500	200	100	80			15		10	18				40						
2N914	SH	S	N	360	200	40	20			30	120	10					300						
2N915	AH	S	N	360	200	70	50			50	200	10	50				250						
2N916	AH	S	N	360	200	45	25			50	200	10	50				300						
2N929	A	S	N	600	175	45	45			40	120	0.01	150				1						
2N930	A	S	N	600	175	45	45			100	300	0.01	150				1						
2N956	AH	S	N	500	200	75	50			100	300	150	50				70						
2N995	AH	S	P	360	200	20	15			35	140	20					100						
2N1008	A	G	P	300	85	20	15																
2N1008A	A	G	P	300	85	40	35									40							
2N1008B	A	G	P	300	85	60	55									20							
2N1015	SP	S	N	150	150	30	30			10		2											
2N1015A	SP	S	N	150	150	60	60			10		2											
2N1047	AP	S	N	40W	200	80				12	36	500											
2N1049	AP	S	N	40W	200	80				30	90	500											
2N1050	AP	S	N	40W	200	120				30	90	500					500						
2N1056	A	G	P	240	100	70	50			18	43	20					500						
2N1057	A	G	P	240	100	45	45			34	90	20	10				4						
2N1058	G	N	S	50	75	20	20																
2N1059	A	G	N	180	75	40	15										10						
2N1067	SP	S	N	5W	175	60	30			15	75	200					0.75						
2N1068	SP	S	N	10W	175	60	30			15	75	750					0.75						
2N1069	SP	S	N	50W	175	60	45			20	50	1.5A					0.5						
2N1070	SP	S	N	50W	175	60	45			20	50	1.5A					0.5						

TYPE	TOSHIBA	NEC	HITACHI	mitsubishi	MATSUSHITA	FUJITSU	SONY	SANYO	NOTE
2N654	2SB415			2SB453	2SB324			2SB186	
2N655	2SB415			2SB453	2SB324			2SB186	
2N656	2SC481	2SC57	2SC685	2SC1018	2SC697A	2SC1082		2SC614	
2N656A	2SC481	2SC57	2SC685	2SC1018	2SC697A	2SC1082		2SC614	
2N657	2SC981	2SC698	2SC685	2SC1018	2SC697A		2SC795	2SC614	
2N680									
2N696A	2SC503	2SC959	2SC479		2SC696	2SC215	2SC756		
2N697	2SC503	2SC959	2SC479		2SC696	2SC215	2SC756		
2N697A	2SC503	2SC959	2SC708						
2N698	2SC510	2SC49	2SC708A		2SC696A	2SC1069	2SC1124		
2N699	2SC510	2SC49	2SC708A		2SC696A	2SC1069	2SC1124		
2N702	2SC984	2SC67	2SC907A		2SC563	2SC203		2SC423	
2N703	2SC984	2SC67	2SC907A		2SC563	2SC203		2SC423	
2N705								2SC423	
2N706	2SC984	2SC68	2SC907A	2SC302	2SC563	2SC203	2SC1128	2SC423	
2N706A	2SC984	2SC68	2SC907A	2SC302	2SC563	2SC203	2SC1128	2SC423	
2N706B	2SC984	2SC67	2SC907A	2SC302	2SC563	2SC203	2SC1128	2SC423	
2N708	2SC979	2SC67	2SC907A	2SC302	2SC563	2SC203		2SC423	
2N718	2SC979	2SC69	2SC907A	2SC302					
2N718A	2SC979	2SC69	2SC907A	2SC302					
2N728	2SC555			2SC447					
2N729	2SC555			2SC447					
2N753	2SC979	2SC68	2SC907A	2SC302	2SC563	2SC203	2SC1128	2SC423	
2N759	2SC979	2SC67	2SC907A	2SC302	2SC563	2SC203		2SC423	
2N760	2SC979	2SC67	2SC907A	2SC302	2SC563	2SC203		2SC423	
2N869	2SC979	2SC67	2SC907A	2SC302	2SC563	2SC203		2SC423	
2N911	2SC510		2SC708						
2N912	2SC510		2SC708						
2N914	2SC979	2SC67	2SC907A	2SC302	2SC538A	2SC203		2SC423	
2N915	2SC979		2SC907A	2SC302	2SC538A	2SC202			
2N916	2SC979	2SC67	2SC907A	2SC302	2SC538A	2SC203		2SC423	
2N929	2SC998								
2N930	2SC998								
2N956	2SC495								
2N995									
2N1008	2SB415	2SB223	2SB370A	2SB454	2SB324				
2N1008A	2SB415	2SB224	2SB370A	2SB454					
2N1008B	2SB415	2SB218	2SB370A	2SB454					
2N1015									
2N1015A									
2N1047									
2N1049									
2N1050									
2N1056									
2N1057									
2N1058									
2N1059									
2N1067	2SC547	2SC781		2SC1017					
2N1068	2SC549	2SC635		2SC977					
2N1069	2SC520			2SC1021					
2N1070	2CC520			2SC1021					

TYPE	TOSHIBA	NEC	HITACHI	mitsubishi	MATSUSHITA	FUJITSU	SONY	SANYO	NOTE
2NI084									
2NI085									
2NI090									
2NI091									
2NI092	2SC1237			2SC778					
2NI097									
2NI098									
2NI102									
2NI107									
2NI108									
2NI109									
2NI110									
2NI128	2SB56		2SB77		2SB172			2SB187	
2NI129									
2NI130									
2NI144									
2NI145									
2NI149	2SC376	2SC943			2SC828A	2SC965	2SC403B	2SC933	
2NI150	2SC376	2SC943			2SC828A	2SC965	2SC403B	2SC933	
2NI151	2SC376	2SC943			2SC828A	2SC965	2SC403B	2SC933	
2NI153	2SC376	2SC943			2SC828A	2SC965	2SC403B	2SC933	
2NI155									
2NI175	2SB415		2SB77A	2SB458A	2SB324				
2NI175A	2SB415		2SB77A	2SB458A	2SB324				
2NI177	2SB415		2SB77A	2SB458A	2SB324				
2NI186	2SB421			2SB458B	2SB281				
2NI187	2SB421			2SB458B	2SB281				
2NI188	2SB421			2SB458B	2SB281				
2NI191	2SB421		2SB77A	2SB458B	2SB281				
2NI192	2SB421		2SB77A	2SB458B	2SB281				
2NI193	2SB421		2SB77A	2SB458B	2SB281				
2NI206									
2NI265	2SB54		2SB75	2SB135	2SB173			2SB186	
2NI266	2SB54		2SB75	2SB135	2SB173			2SB186	
2NI273									
2NI274									
2NI287									
2NI287A									
2NI335	2SC510	2SC49	2SC153	2SC309	2SC696A	2SC1069	2SC1124		
2NI336	2SC510	2SC49	2SC153	2SC309	2SC696A	2SC1069	2SC1124		
2NI337	2SC510	2SC49	2SC153	2SC309	2SC696A	2SC1069	2SC1124		
2NI338	2SC503	2SC97A	2SC708A	2SC307	2SC696	2SC202			
2NI339	2SC510	2SC49	2SC153	2SC309	2SC696A	2SC1069	2SC1124		
2NI340	2SC510	2SC49	2SC153	2SC309		2SC1069	2SC1124		
2NI341	2SC510	2SC49	2SC153	2SC309		2SC1069	2SC1124		
2NI342	2SC95		2SC153	2SC310			2SC1124		
2NI352									
2NI382									
2NI383									
2NI408	2SB55		2SB77A		2SB177				
2NI409	2SC998	2SC319			2SC822				
2NI410A	2SC998	2SC319			2SC822				
2NI413	2SB415			2SB457	2SB324				
2NI414	2SB415			2SB457	2SB324				
2NI415	2SB415			2SB457	2SB324				

TYPE	USE	MATERIAL	POLARITY	MAXIMUM RATINGS						ELECTRICAL CHARACTERISTICS														OUTLINE TO.	NOTE		
				Pc 25°C (mW)	Tj (°C)	V _{ce} (V)	V _{ceo} (V)	I _c (mA)	I _{ceo}		h _{FE}			h _{FE}	h _{ie} (Ω)	h _{re} (x10 ⁻⁴)	h _{oe} (μS)	f _T * f _{ice} * f _{ieo} (MHz)	NF (dB)	C _{ob} (pF)	C _{o(tot)} (ps)						
									(μA)	V _{ce(V)}	min.	max.	I _{c(mA)}														
2N1420A	AH	S	N	800	200	60	40			100	300	150															
2N1445	AP	S	N	4 W	200	120	120			20	80	200															
2N1446	A	G	P	200	85	45	25			16	45	20	16														
2N1447	A	G	P	200	85	45	25			35	65	20	30														
2N1448	A	G	P	200	85	45	25			50	90	20	45														
2N1449	A	G	P	200	85	45	25			70	125	20	60														
2N1451	A	G	P	200	85	45	20			20	65	20															
2N1452	A	G	P	200	85	45	20			30	90	20															
2N1470	AP	S	N	55W	200	60	60			15		1A															
2N1471	S	G	P	200	85	12	15						100														
2N1479	SP	S	N	5W	200	60	60			20	60	200															
2N1480	SP	S	N	5W	200	100	100			20	60	200															
2N1481	SP	S	N	5W	200	60	60			35	100	100															
2N1482	SP	S	N	5W	200	100	100			35	100	100															
2N1483	SP	S	N	25W	200	60	60			25	60	60															
2N1484	SP	S	N	25W	200	100	100			20	60	750															
2N1485	SP	S	N	25W	200	60	60			35	100	750															
2N1486	SP	S	N	25W	200	100	100			35	100	750															
2N1505	AHP	S	N	800	175	50	20			7	100	0.1A															
2N1506	AHP	S	N	800	175	60	20			10	100	0.1A															
2N1506A	AHP	S	N	800	200	80	50			10	100	0.1A															
2N1524	AH	G	P	80	85	24								17													
2N1525	AH	G	P	80	85	24								17													
2N1613	S	S	N	800	200	75	50			40	120	150	30														
2N1613A	S	S	N	1 W	200	75	50			40	120	150	30														
2N1613B	S	S	N	1 W	200	120	55			40	120	150	30														
2N1691	AP	S	N	40W	200	120	120			20	60	500															
2N1700	S	S	N	5W	200	60	60			20	80	100															
2N1701	S	S	N	25W	200	60	60			20	80	300															
2N1705	A	G	P	200	100	18	12							70													
2N1706	A	G	P	200	100	25	18			60	120	20	50														
2N1707	A	G	P	200	100	30	25			30	150	10	40														
2N1708	SH	S	N	1 W	175	25	12			20		10															
2N1709	AHP	S	N	15W	175	75	30			7.5	75	0.35A															
2N1710	AHP	S	N	15W	175	60	30			4	100	0.35A															
2N1711	S	S	N	800	200	75	50			100	300	150	50														
2N1711A	AH	S	N	1 W	200	75	50			100	300	150	50														
2N1711B	AH	S	N	1 W	200	120	55			100	300	150	50														
2N1714A	AP	S	N	20W	175	90	60			20	60	200															
2N1715	AP	S	N	20W	175	150	100			20	60	200															
2N1716	AP	S	N	20W	175	90	60			40	120	200															
2N1717	AP	S	N	20W	175	150	100			40	120	200															
2N1718	AP	S	N	20W	175	90	60			20	60	200															
2N1720	AP	S	N	20W	175	90	60			40	120	200															
2N1768	S	S	N	40W	200	60	40			35	100	750															
2N1769	S	S	N	40W	200	100	55			35	100	750															
2N1837A	SH	S	N	800	175	80	30			40	120	0.15A															
2N1886	AHP	S	N	20W	175	60	60			20	80	0.5A															
2N1889	AH	S	N	800	200	100	80			40	120	150	30														
2N1890	AH	S	N	800	200	100	80			100	300	150	50														
2N1893	AH	S	N	800	200	120	100			40	120	150	30														
2N1924	A	G	P	225	100	60	40	500		34	65	20	30	700	2	15	1			18		5					GE
2N1925	A	G	P	225	100	60	40	500		53	90	20	44	1200	3	20	1.3			18		5					GE
2N1926	A	G	P	225	100	60	40	500		72	121	20	60	1500	4	25	1.5			18		5					GE
2N1943	A	S	N	800	200	60	60			30	90	200	12														

TYPE	TOSHIBA	NEC	HITACHI	MITSUBISHI	MATSUSHITA	FUJITSU	SONY	SANYO	NOTE
2NI420A									
2NI445	2SC510	2SC49	2SC708A		2SC696A		2SC1124		
2NI446	2SB226			2SB454	2SA720				
2NI447	2SB226			2SB454	2SA720				
2NI448	2SB226			2SB454	2SA720				
2NI449	2SB226			2SB454	2SA720				
2NI451	2SB226			2SB454	2SA720				
2NI452	2SB226			2SB454	2SA720				
2NI470									
2NI471									
2NI479		2SC698		2SC1017		2SC866			
2NI480		2SC698							
2NI481		2SC698		2SC1017		2SC866			
2NI482		2SC698							
2NI483									
2NI484									
2NI485									
2NI486									
2NI505	2SC1382	2SC139		2SC775	2SC1384	2SC797			
2NI506	2SC1382	2SC139		2SC775	2SC1384	2SC797			
2NI506A	2SC1382	2SC149		2SC775		2SC1069			
2NI524									
2NI525									
2NI613	2SC498	2SC97A	2SC479		2SC696	2SC202	2SC1056		
2NI613A				2SC1018					
2NI613B		2SC960		2SC1018					
2NI691									
2NI700		2SC1098	2SC819	2SC1155	2SC1226A				
2NI701									
2NI705	2SB189		2SB89		2SB174			2SB185	
2NI706	2SB189		2SB89		2SB174			2SB185	
2NI707	2SB189		2SB89		2SB173			2SB185	
2NI708									
2NI709	2SC489			2SC737					
2NI710	2SC551	2SC598		2SC737					
2NI711			2SC479	2SC307		2SC212			
2NI711A				2SC1018					
2NI711B									
2NI714A	2SC508	2SC92			2SC901				
2NI715	2SC508	2SC92			2SC901				
2NI716	2SC508	2SC92			2SC901				
2NI717	2SC508				2SC901				
2NI718	2SC508				2SC901				
2NI720	2SC508				2SC901				
2NI768	2SC493				2SC901				
2NI769	2SC492								
2NI837A	2SC503	2SC959		2SC307		2SC202			
2NI886		2SC92							
2NI889	2SC510	2SC92	2SC708A	2SC308	2SC696A	2SC1069	2SC1124		
2NI890	2SC510	2SC92	2SC708A	2SC308	2SC696A	2SC1069	2SC1124		
2NI893	2SC510	2SC92	2SC708A	2SC309	2SC696A		2SC1124		
2NI924	2SB421			2SB454					
2NI925	2SB421			2SB454					
2NI926	2SB421			2SB454					
2NI943									

TYPE	USE	MATERIAL	POLARITY	MAXIMUM RATINGS						ELECTRICAL CHARACTERISTICS											OUTLINE TO.	NOTE	
				Pc 25°C (mW)	Tj (°C)	V _{DR} (V)	V _{DB} (V)	I _c (mA)	I _{DB}		h _{FE}			h _{FE}	h _{ie} (Ω)	h _{re} (×10 ⁻⁴)	h _{oe} (μS)	f _T #100 (MHz)	NF (dB)	C _{ob} (pF)			C _o r _{bb} (ps)
									(μA)	V _{DR} (V)	min	max.	I _c (mA)										
2N1973	A	S	N	800	200	100	80				75	10	76				60						
2N1974	A	S	N	800	200	100	80				35	10	36				50						
2N1975	A	S	N	800	200	100	80				15	10	18				40						
2N1997	S	G	P	250	100	45	15				40	200	100				3						
2N1998	S	G	P	250	100	35	15				70	225	100	20			5.6						
2N2007	SC	S	N	800	200	175	110				30	90	10				40						
2N2017	A	S	N	I W	200	60	60				50	200	200										
2N2033	SP	S	N	5 W	200	80	60				20	60	500				1						
2N2034	SP	S	N	14 W	200	80	60				20	60	1 A				1						
2N2035	SP	S	N	17 W	200	80	60				20	60	1.5 A				1						
2N2036	SP	S	N	17.5 W	200	80	60				20	60	2 A				1						
2N2094		G	P	100	85	25	25				40		1	40			30						
2N2102	SH	S	N	5 W	200	120	120				35	10	35										
2N2102A	SH	S	N	I W	200	120	120				40	120	150	30									
2N2106	A	S	N	I W	150	60	60				12	36	200										
2N2107	A	S	N	I W	150	60	60				30	90	200										
2N2108	A	S	N	I W	150	60	60				75	200	200										
2N2171	A	G	P	200	100	50	25				110	250	20	120									
2N2172	S	G	P	200	85	20	15				30	150	10	0.97			5						
2N2173	SH	G	P	240	100	25	15				30		200										
2N2192	SH	S	N	800	200	60	40				100	300	150										
2N2192A	SH	S	N	800	200	60	40				100	300	150										
2N2192B	SH	S	N	800	200	60	40				100	300	150										
2N2193	SH	S	N	800	200	80	50				40	120	150										
2N2193A	SH	S	N	800	200	80	50				40	120	150										
2N2193B	SH	S	N	800	200	80	50				40	120	150										
2N2194	SH	S	N	800	200	60	40				20	60	150										
2N2194A	SH	S	N	800	200	60	40				20	60	150										
2N2194B	SH	S	N	800	200	60	40				20	60	150										
2N2196	AP	S	N	2 W	175	80	60				30	90	200	30									
2N2197	AP	S	N	2 W	175	80	60				75	200	200	30									
2N2218	SH	S	N	800	175	60	30				40	120	150				250						
2N2218A	SH	S	N	800	175	75	40				40	120	0.15A	30			250						
2N2219	SH	S	N	800	175	60	30				100	300	150				250						
2N2219A	SH	S	N	800	175	75	40				100	200	0.15A	50			300						
2N2221	SH	S	N	500	175	60	30				40	120	150				250						
2N2221A	SH	S	N	500	175	75	40				40	120	0.15A	30			250						
2N2222	SH	S	N	500	175	60	30				100	300	150				250						
2N2222A	SH	S	N	500	175	75	40				100	300	0.15A	50			300						
2N2224	SH	S	N	800	175	65	40				35	115	10				250						
2N2239	A	S	N	I W	150	60	50				30	200	200										
2N2270	A	S	N	5 W	200	60	45				30		1 A	50									
2N2297	AH	S	N	800	200	80	35				40	120	150				60						
2N2330	SC	S	N	800	150	30	20				50		10				100						
2N2339	AP	S	N	40 W	200	60	40				6		1.5 A				0.7						
2N2374	A	G	P	250	100	35	35				100	300	100	100									
2N2375	A	G	P	250	100	35	35				35	110	100	35									
2N2376	A	G	P	250	100	35	35				35	110	100	35									
2N2410	SH	S	N	800	200	60	30				30	120	10				200						
2N2430	A	G	N	280	75	32	32				60	210	0.1 A				10						
2N2443	AH	S	N	800	200	120	100				50	150	50	45			50						
2N2447	A	G	P	75	85	45	24							25									
2N2448	A	G	P	75	85	45	24							25									
2N2449	A	G	P	75	85	35	20							50									

TYPE	TOSHIBA	NEC	HITACHI	MITSUBISHI	MATSUSHITA	FUJITSU	SONY	SANYO	NOTE
2N1973	2SC510	2SC49	2SC153	2SC309	2SC696	2SC1069	2SC1124		
2N1974	2SC510	2SC49	2SC153	2SC309	2SC696	2SC1069	2SC1124		
2N1975	2SC510	2SC49	2SC153	2SC309	2SC696	2SC1069	2SC1124		
2N1997						2SB304 A			
2N1998	2SB201				2SB280				
2N2007	2SC507					2SC627			
2N2017	2SC510	2SC49	2SC708A	2SC1018	2SC696	2SC1069	2SC1124		
2N2033			2SC315		2SC574			2SC614	
2N2034			2SC118		2SC584			2SC616	
2N2035			2SC118		2SC584			2SC616	
2N2036			2SC118		2SC584			2SC616	
2N2094	2SB291	2SB264						2SB303	
2N2102									
2N2102A					2SC1012				
2N2106				2SC1018					
2N2107				2SC1018					
2N2108				2SC1018					
2N2171	2SB421				2SB281				
2N2172	2SB415		2SB156A	2SB495	2SB324				
2N2173	2SB415		2SB156A	2SB495	2SB324				
2N2192	2SC503	2SC138		2SC1018					
2N2192A	2SC503	2SC138		2SC1018					
2N2192B	2SC503	2SC138		2SC1018					
2N2193	2SC512			2SC1018					
2N2193A	2SC512			2SC1018					
2N2193B	2SC512			2SC1018					
2N2194	2SC503	2SC138		2SC1018					
2N2194A	2SC503	2SC138		2SC1018					
2N2194B	2SC503	2SC138		2SC1018					
2N2196	2SC1237	2SC799		2SC778					
2N2197	2SC1237	2SC799		2SC778					
2N2218	2SC503	2SC580		2SC775		2SC827			
2N2218A	2SC503			2SC775		2SC827			
2N2219	2SC503	2SC580		2SC775		2SC827			
2N2219A	2SC503	2SC853		2SC775		2SC827			
2N2221		2SC580							
2N2221A		2SC853							
2N2222		2SC580							
2N2222A		2SC853							
2N2224	2SC503	2SC580							
2N2239		2SC959		2SC1018					
2N2270	2SC502	2SC698			2SC697	2SC541	2SC756-2	2SC614	
2N2297	2SC503								
2N2330	2SC503								
2N2339	2SC520				2SC647				
2N2374									
2N2375									
2N2376									
2N2410									
2N2430	2SC503	2SC580		2SC775					
2N2443	2SC510	2SC49	2SC708H	2SC309	2SC696A	2SC1069	2SC1124		
2N2447	2SB306				2SB289	2SB304			
2N2448	2SB306				2SB289	2SB304			
2N2449	2SB40				2SB288	2SB304			

TYPE	USE	MATERIAL	POLARITY	MAXIMUM RATINGS						ELECTRICAL CHARACTERISTICS											OUTLINE TO.	NOTE						
				Pc 25°C (mW)	Tj (°C)	Vas (V)	Vco (V)	Ic (mA)	I _{iso} (μA)	I _{iso}		I _{iso}		I _{iso}	hfe	h _{ie} (Ω)	h _{re} (×10 ⁻⁴)	h _{oe} (μS)	f _T hfe MHz	NF (dB)			Cob (pF)	Coxtb (ps)				
2N2483	A	S	N	360	200	60	60					40	120	10		80						12						
2N2484	A	S	N	360	200	60	60					100	500	10		150							15					
2N2537	SH	S	N	800	200	60	30					50	150	150									250					
2N2538	SH	S	N	800	200	60	30					100	300	150									250					
2N2594	A	S	N	5W	200	80	90					50	150	100		15							40					
2N2632	AP	S	N	40W	175	90	60					40	120	1A		40							20					
2N2657	SP	S	N	1.25W	200	80	60					40	120	1A									20					
2N2699	SH	G	P	150	100	15	8					40	200	10									300					
2N2711	A	S	N	200	125	18	18	100	0.5	18	30	90	2		-30											98	GE	
2N2712	A	S	N	200	125	18	18	100	0.5	18	75	225	2		80											98	GE	
2N2713	A	S	N	200	125	18	18	200	0.1	18	30	90	2		30											98	GE	
2N2714	A	S	N	200	125	18	18	200	0.1	18	75	225	2		80											98	GE	
2N2723	AL	S	N	500	200	80	60					2K	10K	10		1500							100					
2N2724	AL	S	N	500	200	80	60					7K	50K	10		5000							100					
2N2725	AL	S	N	500	200	45	45					2K	10K	0.1A		1500							100					
2N2726	AHP	S	N	1W	200	200	200					30	90	200		30							15					
2N2727	AHP	S	N	1W	200	200	200					75	150	200		75							15					
2N2787	SH	S	N	800	175	75	35					20	50	150		15							250					
2N2788	SH	S	N	800	175	75	35					40	120	150		30							250					
2N2789	SH	S	N	800	175	75	35					100	300	150		80							250					
2N2800	SH	S	P	800	200	50	35					30	90	150									120					
2N2801	SH	S	P	800	200	50	35					75	225	150									120					
2N2828	SP	S	N	40W	200	80	60					20	60	500									1					
2N2829	SP	S	N	40W	200	80	60					20	60	1A									1					
2N2846	S	S	N	800	200	60	30					30	120	150									250					
2N2848	S	S	N	800	200	60	20					40	140	150									250					
2N2853-1	SH	S	N	850	200	60	40					40		1A									30					
2N2854-1	SH	S	N	850	200	60	40					100	300	1A									30					
2N2855-1	SH	S	N	850	200	60	40					40	120	1A									30					
2N2856-1	SH	S	N	850	200	60	40					20	60	1A									30					
2N2863	AH	S	N	800	200	60	25					30	220	200									150					
2N2864	AH	S	N	800	200	60	25					20	200	200									150					
2N2868	SH	S	N	800	200	60	40					40	120	150														
2N2875	AHP	S	P	20W	200	60	50					15	60	50									25					
2N2876	AH	S	N	17.5W	200	80	60					5		2.5A									150					
2N2877	AHP	S	N	53W	200	80	60					20	60	1A		20							30					
2N2878	AHP	S	N	53W	200	80	60					40	120	1A		40							50					
2N2883	AHP	S	N	800	200	40	20					20		100									400					
2N2884	AHP	S	N	800	200	40	20					20		100									400					
2N2904	SH	S	P	3W	200	60	40					40		120									200					
2N2905	SH	S	P	3W	200	60	40					100	300	150									200					
2N2906	SH	S	P	1.8W	200	60	40					40	120	150									200					
2N2907	SH	S	P	1.8W	200	60	40					100	300	150									200					
2N2923	A	S	N	200	125	25	25	100	0.1	25	115		2		90								160			98	GE	
2N2924	A	S	N	200	125	25	25	100	0.1	25	155		2		150								160			98	GE	
2N2925	A	S	N	200	125	25	25	100	0.1	25	215		2		235								160			98	GE	
2N2926	A	S	N	200	125	18	18	200	0.5	18					35								120		7	98	GE	
2N2927	S	S	P	800	200	25	25					30	130	50		25							100					
2N2939	AHP	S	N	800	300	75	60					60	240	150									150					
2N2941	AHP	S	N	800	200	150	100					60	240	150									150					
2N2947	AP	S	N	25W	175	60	60					2.5	55	400									100					
2N2948	AP	S	N	25W	175	40	40					2.5	100	400									100					
2N2949	AP	S	N	6W	175	60	60					5	100	40									100					
2N2950	AP	S	N	6W	175	60	60					5	100	40									100					
2N2951	AP	S	N	3W	175	60	60					20	150	10									200					

TYPE	TOSHIBA	NEC	HITACHI	mitsubishi	MATSUSHITA	FUJITSU	SONY	SANYO	NOTE
2N2483									
2N2484									
2N2537									
2N2538									
2N2594				2SC1018					
2N2632									
2N2657									
2N2699									
2N2711	2SC1000		2SC458			2SC1372			
2N2712	2SC1000		2SC458			2SC1372			
2N2713	2SC396	2SC1216	2SC468			2SC724			
2N2714	2SC396	2SC1216	2SC468			2SC724			
2N2723									
2N2724									
2N2725									
2N2726									
2N2727									
2N2787									
2N2788									
2N2789									
2N2800									
2N2801									
2N2828									
2N2829									
2N2846									
2N2848									
2N2853-I				2SC1014					
2N2854-I				2SC1014					
2N2855-I				2SC1014					
2N2856-I				2SC1014					
2N2863									
2N2864									
2N2868				2SC1018					
2N2875									
2N2876	2SC551	2SC598		2SC737					
2N2877									
2N2878									
2N2883	2SC1165	2SC890		2SC908					
2N2884	2SC1165	2SC890		2SC908					
2N2904									
2N2905									
2N2906									
2N2907									
2N2923	2SC1000			2SC1312					
2N2924	2SC1000			2SC1312					
2N2925	2SC1000			2SC1312					
2N2926		2SC1216				2SC1231		2SC933FP	
2N2927									
2N2939									
2N2941									
2N2947	2SC551			2SC737					
2N2948	2SC551			2SC737					
2N2949									
2N2950									
2N2951				2SC1018					

GE

TYPE	USE	MATERIAL	POLARITY	MAXIMUM RATINGS				ELECTRICAL CHARACTERISTICS											OUTLINE TO.	NOTE				
				Pc 25°C (mW)	Tj (°C)	V _{cs} (V)	V _{ce0} (V)	I _c (mA)	I _{ceo} (μA)	V _{ceV}	h _{FE}		h _{FE}	h _{ie}	h _{ie} (Ω)	h _{re} (x10)	h _{oe} (μ Ω)	f ₁₂₀ dB (MHz)			NF	C _{ob} (pF)	C _{ox} (ps)	
2N2952	AP	S	N	1.8W	175	60	60					20	150	10					200					
2N3013	SH	S	N	360	200	40	15					30	120	30					350					
2N3014	SH	S	N	360	200	40	20					30	120	30					350					
2N3015	SH	S	N	800	200	60	30					30	120	150					250					
2N3016	AHP	S	N	3.33W	150	100	50					60	150	1A					200					
2N3017	AHP	S	N	3.33W	150	100	50					60	150	1A					200					
2N3021	SHP	S	P	25W	175	30	30					20	60	1A					60					
2N3022	SHP	S	P	25W	175	45	45					20	60	1A					60					
2N3023	SHP	S	P	25W	175	60	60					20	60	1A					60					
2N3024	SHP	S	P	25W	175	30	30					50	180	1A					60					
2N3025	SHP	S	P	25W	175	45	45					50	180	1A					60					
2N3026	SHP	S	P	25W	175	60	60					50	180	1A					60					
2N3053	SH	S	N	5W	200	60	40					50	250	150					100					
2N3054	AP	S	N	25W	200	90	60	4A				25	100	500					30			66	GE	
2N3072	S	S	P	800	200	60	60					30	130	50					130					
2N3107	S	S	N	800	200	100	60					100	300	150					70					
2N3108	S	S	N	800	200	100	60					40	120	150					60					
2N3109	S	S	N	800	200	80	40					100	300	150					70					
2N3110	S	S	N	800	200	80	40					40	120	150					60					
2N3114	AH	S	N	800	200	150	150					30	120	30			25		40					
2N3118	AH	S	N	1W	200	85	60					50	275	25					250					
2N3120	S	S	P	800	200	45	45					30	130	50			25		130					
2N3122	A	S	N	800	200	50	30					25	100	300					60					
2N3133	SH	S	P	600	200	50	35					40	120	150					200					
2N3134	SH	S	P	600	200	50	35					100	300	150					200					
2N3135	SH	S	P	400	200	50	35					40	120	150					200					
2N3136	SH	S	P	400	200	50	35					100	300	150					200					
2N3138	AHP	S	N	20W	200	65	65					10		1A					100					
2N3140	AHP	S	N	20W	200	65	65					10		1A					100					
2N3142	AHP	S	N	25W	200	65	65					10		1A					100					
2N3144	AHP	S	N	25W	200	65	65					10		1A					100					
2N3199	AHP	S	P	40W	200	40	40					20	60	1A					10					
2N3200	AHP	S	P	40W	200	60	60					20	60	1A					10					
2N3205	AHP	S	P	40W	200	40	40					20	60	500					10					
2N3206	AHP	S	P	40W	200	60	60					20	60	500					10					
2N3210	SH	S	N	360	200	40	15					30	120	10					300					
2N3226	AP	S	N	75W	200	35	35					20	50	2A			20		30					
2N3229	AHP	S	N	17.5W	200	105	60					5		2.5A					150					
2N3244	SH	S	P	1W	200	40	40					50	150	500					175					
2N3245	SH	S	P	1W	200	50	50					30	90	500					150					
2N3252	SH	S	N	1W	200	60	30					30	90	500					200					
2N3253	SH	S	N	1W	200	75	40					25	75	375					175					
2N3295	AHP	S	N	800	175	60	60					20	60	10					200					
2N3296	AHP	S	N	700	175	60	60					5	50	40					100					
2N3297	AHP	S	N	25W	175	60	60					2.5	35	400					100					
2N3298	AHP	S	N	1W	175	25	15					80	240	10					200					
2N3299	SH	S	N	800	200	60	30					40	120	150					250					
2N3300	SH	S	N	800	200	60	30					100	300	150					250					
2N3301	SH	S	N	360	200	60	30					40	120	150					250					
2N3302	SH	S	N	360	200	60	30					100	300	150					250					
2N3309	AHP	S	N	3.5W	175	50	50					5	100	30					300					
2N3326	SH	S	N	800	175	60	45					40	120	150					250					
2N3375	AHP	S	N	11.6W	200	65	40					10	100	250					400					
2N3390	A	S	N	200	125	25	25	100	0.1	18	400	800	2	400					2			98	GE	
2N3391	A	S	N	200	125	25	25	100	0.1	25	250	500	2	250					120	1.9			98	GE

TYPE	TOSHIBA	NEC	HITACHI	mitsubishi	MATSUSHITA	FUJITSU	SONY	SANYO	NOTE
2N2952									
2N3013									
2N3014									
2N3015									
2N3016									
2N3017									
2N3021									
2N3022									
2N3023									
2N3024									
2N3025									
2N3026									
2N3053									
2N3054	2SD118	2SD283							
2N3072				2SC1018					
2N3107									
2N3108									
2N3109				2SC1018					
2N3110				2SC1018					
2N3114									
2N3118									
2N3120									
2N3122	2SC504	2SC959	2SC479		2SC696	2SC200			
2N3133									
2N3134									
2N3135									
2N3136									
2N3138									
2N3140									
2N3142									
2N3144									
2N3199									
2N3200									
2N3205									
2N3206									
2N3210									
2N3226									
2N3229									
2N3244									
2N3245									
2N3252									
2N3253									
2N3295	2SC998			2SC741		2SC543			
2N3296									
2N3297	2SC551			2SC737		2SC543			
2N3298	2SC501	2SC67		2SC306		2SC88			
2N3299	2SC501	2SC67		2SC306		2SC88			
2N3300	2SC501	2SC67		2SC306		2SC88			
2N3301	2SC501	2SC67		2SC300		2SC88			
2N3302	2SC501	2SC67		2SC300					
2N3309				2SC1011		2SC1465			
2N3326									
2N3375	2SC549	2SC598		2SC691		2SC543		2SC614	
2N3390	2SC732	2SC923	2SC1344			2SC1372	2SC403C	2SC933FP	
2N3391	2SC732	2SC900	2SC458LG		2SC644	2SC644			

GE

TYPE	USE	MATERIAL	POLARITY	MAXIMUM RATINGS								ELECTRICAL CHARACTERISTICS											OUTLINE TO.	NOTE
				Pc 25°C (mW)	Tj (°C)	Vas (V)	Vcto (V)	Ic (mA)	I _{iso}		hFE		hfe	f _{ie}	f _{oe}	f _{oe} (×10)	h _{oe} (μS)	f _t **f _{oe} (MHz)	NF (dB)	Cob (pF)	Coxbb (ps)			
									(μA)	V _{CE} (V)	min.	max.										IC(mA)		
2N3391A	A	S	N	200	125	25	25	100	0.1	25	250	500	2	250									98	GE
2N3392	A	S	N	200	125	25	25	100	0.1	25	150	300	2	150									98	GE
2N3393	A	S	N	200	125	25	25	100	0.1	25	90	180	2	90									98	GE
2N3394	A	S	N	200	125	25	25	100	0.1	25	55	110	2	55									98	GE
2N3395	A	S	N	200	125	25	25	100	0.1	25	150	500	2	150								10	98	GE
2N3396	A	S	N	200	125	25	25	100	0.1	25	90	500	2	90								10	98	GE
2N3397	A	S	N	200	125	25	25	100	0.1	25	55	500	2	55								10	98	GE
2N3398	A	S	N	200	125	25	25	100	0.1	25	55	800	2	55								10	98	GE
2N3402	A	S	N	560	150	25	25	500	0.1	25	75	225	2	75	5100	2.7	14						98	GE
2N3403	A	S	N	560	150	25	25	500	0.1	25	180	540	2	180	9000	4.5	21						98	GE
2N3404	A	S	N	560	150	50	50	500	0.1	50	75	225	2	75	4200	2	10						98	GE
2N3405	A	S	N	560	150	50	50	500	0.1	50	180	540	2	100	8300	4	20						98	GE
2N3414	A	S	N	500	160	25	25	500	0.1	25	75	225	2	75	5100	2.7	14						98	GE
2N3415	A	S	N	500	160	25	25	500	0.1	25	180	540	2	180	9000	4.5	21						98	GE
2N3416	A	S	N	500	160	50	50	500	0.1	50	75	225	2	75	4200	2.7	10						98	GE
2N3417	A	S	N	500	160	50	50	500	0.1	50	180	540	2	100	8300	4	20						98	GE
2N3418	SP	S	N	800	175	85	60				20	60	1A									40		
2N3420	SP	S	N	800	175	85	60				40	120	1A									40		
2N3440	AH	S	N	1W	200	300	250				40	160	20	25								15		
2N3441	AP	S	N	25W	200	160	140	3A			25	100	500									0.8	66	GE
2N3442	AP	S	N	117W	200	160	140	5A			20	70	3A										3	GE
2N3444	SH	S	N	1W	200	80	50				20	60	500									150		
2N3462	A	S	N	300	200	50	35				100	300	10	150								10		
2N3463	A	S	N	300	200	60	45				120	360	10	150								45		
2N3464	AHP	S	N	5W	200	60	40				35	100	200	30								50		
2N3467	SH	S	P	1W	200	40	40				40	120	500									175		
2N3468	SH	S	P	1W	200	50	50				25	75	500									150		
2N3469	AHP	S	N	1.25W	200	35	25				100	350	500	100								20		
2N3478	AH	S	N	200	200	30	15				25	150	2	25								750		
2N3485	SH	S	P	2W	200	60	40				40	120	150									200		
2N3486	SH	S	P	2W	200	60	40				100	300	150									200		
2N3500	AH	S	N	1W	200	150	150				40	120	150	50								150		
2N3506	SH	S	N	1W	200	60	40				40	200	1.5A									60		
2N3507	SH	S	N	1W	200	80	50				30	150	1.5A									60		
2N3508	SH	S	N	400	200	40	20				40	120	10									500		
2N3510	SH	S	N	360	200	40	10				25	150	150	20								350		
2N3511	SH	S	N	360	200	40	15				30	120	150	20								450		
2N3512	SH	S	N	800	200	60	35				10		500									250		
2N3526	AH	S	N	800	200	130	120				30	120	30	25								40		
2N3544	AH	S	N	300	175	25	25				25		10									600		
2N3547	A	S	P	360	200	60	60				100	500	1A	120								45		
2N3548	A	S	P	400	200	60	45				100	300	10	150								60		
2N3553	AHP	S	N	7W	200	65	40				10	100	250									400		
2N3554	SH	S	N	800	200	60	30				25	100	750									150		
2N3563	AH	S	N	260	125	30	12				20	200	8	20								600		
2N3564	AH	S	N	260	125	30	15				20	500	12	20								400		
2N3565	A	S	N	260	125	30	25				150	600	1	120								40		
2N3566	A	S	N	300	125	40	30				150	600	10									40		
2N3567	A	S	N	300	125	80	40				40	120	150									60		
2N3568	A	S	N	300	125	80	60				40	120	150									60		
2N3569	A	S	N	300	125	80	40				100	300	150									60		
2N3579	AH	S	P	400	200	60	60				30	120	1	30								80		
2N3580	AH	S	P	400	200	60	60				60	240	1	60								80		
2N3581	AH	S	P	400	200	50	40				50	150	100	50								30		
2N3582	AH	S	P	400	200	50	40				100	300	100	100								30		

TYPE	TOSHIBA	NEC	HITACHI	MITSUBISHI	MATSUSHITA	FUJITSU	SONY	SANYO	NOTE
2N3391A	2SC732	2SC945	2SC458LG	2SC300			2SC631A		
2N3392	2SC400	2SC1216	2SC1085	2SC1312	2SC478	2SC724		2SC933FP	
2N3393	2SC400	2SC1216	2SC1085	2SC1312	2SC478	2SC724		2SC933FP	
2N3394	2SC400	2SC1216	2SC1085	2SC1312	2SC478	2SC724		2SC933FP	
2N3395	2SC1000	2SC1216		2SC712F		2SC724	2SC631		
2N3396	2SC1000	2SC1216		2SC712F		2SC724	2SC631		
2N3397	2SC1000	2SC1216		2SC712F		2SC724	2SC631		
2N3398	2SC1000	2SC1216		2SC712F		2SC724	2SC631		
2N3402					2SC1346				
2N3403					2SC1346				
2N3404					2SC1347				
2N3405					2SC1347				
2N3414					2SC1346				
2N3415					2SC1346				
2N3416					2SC1347				
2N3417					2SC1347				
2N3418									
2N3420									
2N3440									
2N3441		2SD284					2SD56		
2N3442		2SD286							
2N3444									
2N3462	2SC734	2SC1216	2SC317	2SC620	2SC456	2SC725	2SC318		
2N3463	2SC734	2SC1216	2SC317	2SC620	2SC456	2SC725	2SC1129		
2N3464									
2N3467									
2N3468									
2N3469									
2N3478									
2N3485									
2N3486									
2N3500									
2N3506									
2N3507									
2N3508									
2N3510									
2N3511									
2N3512									
2N3526									
2N3544									
2N3547									
2N3548									
2N3553	2SC549	2SC598				2SC542		2SC614	
2N3554									
2N3563	2SC387A	2SC922		2SC763	2SC1047	2SC721	2SC1129		
2N3564		2SC922		2SC763	2SC1047	2SC721	2SC1129		
2N3565		2SC838	2SC461	2SC710					
2N3566				2SC620	2SC456	2SC725		2SC933FP	
2N3567			2SC284	2SC714					
2N3568			2SC284	2SC1211					
2N3569			2SC284	2SC714					
2N3579									
2N3580									
2N3581									
2N3582									

GE

TYPE	USE	MATERIAL	POLARITY	MAXIMUM RATINGS				ELECTRICAL CHARACTERISTICS											OUTLINE TO.	NOTE			
				Pc 25°C (mW)	Tj (°C)	Vas (V)	Vcso (V)	Ic (mA)	I _{ceo}		h _{FE}		hfe	h _{ie} (Ω)	h _{re} (×10 ³)	hoe (μS)	f _T *f _{oe} **f _{ob} (MHz)	NF (dB)			Cob (pF)	Coxrbb (ps)	
									(μA)	Vce(V)	min	max											Ic(mA)
2N3583	AHP	S	N	35W	200	250	175		40	200	500	25					10						
2N3589	AHP	S	N	2W	175	200	200		30	90	200	30					15						
2N3590	AHP	S	N	2W	175	200	200		75	150	200	75					15						
2N3591	AHP	S	N	1W	175	200	200		30	90	200	30					15						
2N3592	AHP	S	N	1W	175	200	200		75	150	200	75					15						
2N3593	AHP	S	N	1W	175	200	200		30	90	200	30					15						
2N3594	AHP	S	N	1W	175	200	200		75	150	200	75					15						
2N3600	AH	S	N	200	200	30	15		20	150	3	40					850						
2N3605	S	S	N	200	150	18	14		30		10						300						
2N3606	S	S	N	200	150	18	14		30		10						300						
2N3607	S	S	N	200	150	18	14		30		10						300						
2N3619	AHP	S	N	7.5W	175	75	40		40		1A						200						
2N3620	AHP	S	N	7.5W	175	75	40		40		1A						200						
2N3621	AHP	S	N	30W	175	75	40		40		1A						200						
2N3622	AHP	S	N	30W	175	75	40		40		1A						200						
2N3623	AHP	S	N	7.5W	175	75	40		40		1A						200						
2N3624	AHP	S	N	7.5W	175	75	40		40		1A						200						
2N3625	AHP	S	N	30W	175	75	40		40		1A						200						
2N3626	AHP	S	N	30W	175	75	40		40		1A						200						
2N3627	AHP	S	N	7.5W	175	100	50		40		1A						200						
2N3628	AHP	S	N	7.5W	175	100	50		40		1A						200						
2N3629	AHP	S	N	30W	175	100	50		40		1A						200						
2N3630	AHP	S	N	30W	175	100	50		40		1A						200						
2N3632	AHP	S	N	23W	200	65	40		10	150	250						250						
2N3633	SH	S	N	300	200	15	6		50	150	10												
2N3638	SH	S	P	300	125	25	25		30		50	25					100						
2N3638A	SH	S	P	300	125	25	25		100		50	100					150						
2N3641	AHP	S	N	350	125	60	30		40	120	150						250						
2N3642	AHP	S	N	350	125	60	45		40	120	150						250						
2N3643	AHP	S	N	350	125	60	30		100	300	150						250						
2N3644	SH	S	P	300	125	45	45		115	300	50						200						
2N3659	AH	S	N	4W	200	220	170		20		10	20					50						
2N3660	AHP	S	P	5W	200	40	30		25	100	500						25						
2N3661	AHP	S	P	5W	200	60	50		25	100	500						25						
2N3662	AH	S	N	200	125	18	12	25	0.5	15	20	8					700 ^{60MHz}	1.5			98		GE
2N3663	AH	S	N	200	125	30	12	25	0.5	15	20	8					700 ^{60MHz}	3			98		GE
2N3675	SP	S	N	8.8W	200	90	55		12	60	1A						1						
2N3678	SH	S	N	800	200	75	55		40	120	150						250						
2N3681	AH	S	N	200	200	10	7		20	220	2	20					1						
2N3682	AH	S	N	360	200	40	15		40	120	10	45					600						
2N3683	AH	S	N	200	200	30	12		20	150	8	30					1						
2N3688	AH	S	N	200	125	40	40		30		4						400						
2N3689	AH	S	N	200	125	40	40		30		4						400						
2N3690	AH	S	N	200	125	40	40		30		4						400						
2N3691	A	S	N	200	125	35	20		40	160	10	40					200						
2N3692	A	S	N	200	125	35	20		100	400	10	100					200						
2N3693	AH	S	N	200	125	45	45		40	160	10						200						
2N3694	AH	S	N	200	125	45	45		100	400	10						200						
2N3702	A	S	P	300	150	40	25		60	300	50						100						
2N3703	A	S	P	300	150	50	30		30	150	50						100						

TYPE	TOSHIBA	NEC	HITACHI	mitsubishi	MATSUSHITA	FUJITSU	SONY	SANYO	NOTE
2N3583									
2N3589									
2N3590									
2N3591									
2N3592									
2N3593									
2N3594									
2N3600									
2N3605									
2N3606									
2N3607									
2N3619				2SC691				2SC614	
2N3620				2SC691				2SC614	
2N3621	2SC1077	2SC1037		2SC690					
2N3622	2SC1077	2SC1037		2SC690					
2N3623				2SC691				2SC614	
2N3624				2SC691				2SC614	
2N3625	2SC1077	2SC1037		2SC690					
2N3626	2SC1077	2SC1037		2SC690					
2N3627									
2N3628									
2N3629									
2N3630									
2N3632	2SC551			2SC737		2SC543			
2N3633									
2N3638									
2N3638A									
2N3641				2SC620	2SC456				
2N3642				2SC620	2SC456				
2N3643				2SC620	2SC456				
2N3644									
2N3659									
2N3660		2SA635		2SA624					
2N3661		2SA635		2SA624					
2N3662	2SC786	2SC922	2SC683				2SC1129		
2N3663	2SC785	2SC1187	2SC717				2SC1129		
2N3675									
2N3678									
2N3681									
2N3682									
2N3683									
2N3688		2SC1187	2SC717				2SC1129		
2N3689		2SC1187	2SC717				2SC1129		
2N3690		2SC1187	2SC717				2SC1129		
2N3691	2SC732		2SC461	2SC710			2SC632	2SC933FP	
2N3692	2SC732		2SC461	2SC710			2SC632	2SC933FP	
2N3693	2SC732		2SC461	2SC710			2SC632	2SC933FP	
2N3694	2SC732		2SC461	2SC710			2SC632	2SC933FP	
2N3702									
2N3703									

GE

TYPE	USE	MATERIAL	POLARITY	MAXIMUM RATINGS				ELECTRICAL CHARACTERISTICS												OUTLINE TO.	NOTE			
				Pc 25°C (mW)	Tj (°C)	Vca (V)	Vcco (V)	Ic (mA)	Icbo (μA)	hre		hfe	hie (Ω)	hre h (×10)	hoe (μS)	f _T 100 MHz	NF (dB)	Cob (pF)	Coxtb (ps)					
2N3704	A	S	N	360	150	50	30	800			100	300	50					100					18	
2N3705	A	S	N	360	150	50	30				50	150	50					100						
2N3706	A	S	N	360	150	40	20				30	600	50					100						
2N3707	A	S	N	250	150	30	30	100			100	400	400	100										
2N3708	A	S	N	250	150	30	30	100			45	660	660	45										
2N3709	A	S	N	250	150	30	30				45	165	1	45										
2N3710	A	S	N	250	150	30	30				90	330	1	90										
2N3711	A	S	N	250	150	30	30				180	660	1	180										
2N3712	AH	S	P	800	200	150	150				30	150	30	25				40						
2N3719	SHP	S	P	6W	200	40	40				25	180	1A					60						
2N3720	SHP	S	P	6W	200	60	60				25	180	1A					60						
2N3721	A	S	P	200	125	18	18	100	0.5	18	60	660	2	60				120						
2N3722	S	S	P	800	200	80	60				40	150	100					300						
2N3724	SH	S	P	800	200	50	30				60	150	100					300						
2N3724A	SH	S	P	1W		50	30				60	150	100											
2N3725A	SH	S	P	1W		80	50				60	150	100	3										
2N3734	SH	S	P	1W	200	50	30	1A			30	120	1A					300						
2N3735	SH	S	P	1W	200	75	50	1A			20	80	1A					250						
2N3738	AP	S	P	20W	175	250	225	1A			40	200	100	35				15						
2N3739	AP	S	P	20W	175	325	300	1A			40	200	100	35				15						
2N3740	AP	S	P	25W	200	60	60	4A			30	100	250	25				4						
2N3740A	AP	S	P	25W	200	60	60				30	100	250	25				4						
2N3742	AH	S	N	1W	200	300	300				20	200	30	20				30						
2N3744	AHP	S	N	30W	200	60	40				20	60	1A	20				30						
2N3745	AHP	S	N	30W	200	80	60				20	60	1A	20				30						
2N3747	AHP	S	N	30W	200	60	40				40	120	1A	40				40						
2N3748	AHP	S	N	30W	200	80	60				40	120	1A	40				40						
2N3762	SH	S	P	1W	200	40	40				30	120	1A					180						
2N3763	SH	S	P	1W	200	60	60				20	80	1A					150						
2N3766	AP	S	N	20W	175	80	60				40	160	500	40				15						
2N3771	AP	S	N	150W	200	50	40	30A	2mA	50	15	60	15A	40								3		GE
2N3772	AP	S	N	150W	200	100	60	20A	5mA	100	15	60	10A	40								3		GE
2N3773	AP	S	N	150W	200	160	140	16A	2mA	140	15	60	8A									3		GE
2N3798	A	S	P	360	200	60	60				150	450	500	150				30						
2N3818	AHP	S	N	25W	175	60	60				5	50	400	3										
2N3825	AH	S	N	250	150	30	15				20		2					200						
2N3830	SH	S	N	1W	200	80	50				30		150					200						
2N3831	SH	S	N	1W	200	70	40				35		150					200						
2N3843	AH	S	N	200	125	30	30	100	0.5	18	20	40	2					60	² MHz 5.5	3	150	92		GE
2N3843A	AH	S	N	200	125	30	30	100	0.5	18	20	40	2					60	² MHz 5.5	3	150	92		GE
2N3844	AH	S	N	200	125	30	30	100	0.5	18	35	70	2					90	² MHz 5.5	3	150	92		GE
2N3844A	AH	S	N	200	125	30	30	100	0.5	18	35	70	2					90	² MHz 5.5	3	150	92		GE
2N3845	AH	S	N	200	125	30	40	100	0.5	18	60	120	2					120	² MHz 5.5	3	150	92		GE
2N3845A	AH	S	N	200	125	30	30	100	0.5	18	60	120	2					120	² MHz 5.5	3	150	92		GE
2N3852	SHP	S	N	30W	200	60	40				50	150	1A					20						
2N3853	SHP	S	N	30W	200	60	40				30	90	1A					20						
2N3854	AH	S	N	200	150	18	18	100	0.5	18	35	70	2					100			16	25	92	GE
2N3854A	AH	S	N	200	150	30	30	100	0.5	18	35	70	2					100			16	25	92	GE
2N3855	AH	S	N	200	150	18	18	100	0.5	18	60	120	2					130			16	35	92	GE
2N3855A	AH	S	N	200	150	30	30	100	0.5	18	60	120	2					130			16	35	92	GE
2N3856	AH	S	N	200	150	18	18	100	0.5	18	100	200	2					140			16	40	92	GE
2N3856A	AH	S	N	200	150	30	30	100	0.5	18	100	200	2					140			16	40	92	GE
2N3858	AH	S	N	200	125	30	30	100	0.05	40	60	120	2					90				65	92	GE
2N3858A	AH	S	N	200	100	60	60	100	0.05	60	45	1						90				65	92	GE
2N3859	AH	S	N	200	125	30	30	100	0.05	40	100	200	2					90				65	92	GE

TYPE	TOSHIBA	NEC	HITACHI	MITSUBISHI	MATSUSHITA	FUJITSU	SONY	SANYO	NOTE
2N3704									
2N3705									
2N3706									
2N3707	2SC732	2SC900	2SC458LG	2SC871	2SC644		2SC631A		
2N3708	2SC1000	2SC900	2SC458LG		2SC644		2SC631A		
2N3709	2SC1000	2SC900	2SC458LG		2SC644		2SC631A		
2N3710	2SC1000	2SC900	2SC458LG		2SC644		2SC631A		
2N3711	2SC1000	2SC900	2SC458LG		2SC644		2SC631A		
2N3712									
2N3719									
2N3720									
2N3721	2SC1000		2SC458	2SC712		2SC724			
2N3722									
2N3724									
2N3724A									
2N3725A									
2N3734	2SC998	2SC319		2SC730		2SC1479			
2N3735									
2N3738									
2N3739									
2N3740									
2N3740A									
2N3742									
2N3744									
2N3745									
2N3747									
2N3748									
2N3762									
2N3763									
2N3766									
2N3771	2SD114					2SD250			
2N3772	2SD113	2SD132				2SD250			
2N3773			2SD341				2SD340		
2N3798									
2N3818									
2N3825	2SC979	2SC67	2SC907A	2SC301			2SC1128		
2N3830									
2N3831									
2N3843	2SC733		2SC641	2SC712			2SC631A	2SC933FP	
2N3843A	2SC733		2SC641	2SC712			2SC631A	2SC933FP	
2N3844	2SC733		2SC641	2SC712			2SC631A	2SC933FP	
2N3844A	2SC733		2SC641	2SC712			2SC631A	2SC933FP	
2N3845	2SC733		2SC641	2SC712			2SC631A	2SC933FP	
2N3845A	2SC733		2SC641	2SC712			2SC631A	2SC933FP	
2N3852									
2N3853									
2N3854	2SC733		2SC641	2SC712			2SC631A	2SC933FP	
2N3854A	2SC733		2SC641	2SC71			2SC631A	2SC933FP	
2N3855	2SC733		2SC641	2SC712			2SC631A	2SC933FP	
2N3855A	2SC733		2SC641	2SC712			2SC631A	2SC933FP	
2N3856	2SC733		2SC641	2SC712			2SC631A	2SC933FP	
2N3856A	2SC733		2SC641	2SC712			2SC631A	2SC933FP	
2N3858	2SC733		2SC641	2SC712			2SC631A	2SC933FP	
2N3858A	2SC506	2SC1278			2SC1033			2SC715	
2N3859			2SC461	2SC713			2SC631A	2SC933FP	

TYPE	USE	MATERIAL	POLARITY	MAXIMUM RATINGS						ELECTRICAL CHARACTERISTICS										OUTLINE TO	NOTE	
				Pc 25°C (mW)	Tj (°C)	Vca (V)	Vcco (V)	Ic (mA)	Icbo (μA)	hfe		hfe	hie (Ω)	hre (×10 ³)	hoe (μS)	f _T MHz	NF (dB)	Cob (pF)	Coxtbb' (ps)			
2N3859A	AH	S	N	200	100	60	60	100	0.05	60	75	1					90			65	92	GE
2N3860	AH	S	N	200	125	30	30	100	0.05	40	150	300	2				90			65	92	GE
2N3866	AHP	S	N	5W	200	55	30				10	200	50				250					
2N3867	SH	S	P	1W	200	40	40				40	200	1.5A				60					
2N3868	SH	S	P	1W	200	60	60				30	150	1.5A				60					
2N3869	AHP	S	N	2.5W	175	40	20				20	150	30									
2N3877	A	S	N	200	150	70	70	50	0.1	70	20	250	2				160				98	GE
2N3877A	A	S	N	200	150	85	85	50	0.1	70	20	250	2				160				98	GE
2N3878	AHP	S	N	35W	200	120	50				40	200	5A				40					
2N3880	AH	S	N	200	200	30	15				30	200	3				1200					
2N3900	A	S	N	200	125	18	18	100	0.1	18	250	500	2				170				98	GE
2N3900A	A	S	N	200	125	18	18	100	0.1	18	250	500	2				170				98	GE
2N3901	A	S	N	200	125	18	18	100	0.01	15	350	700	2				350				98	GE
2N3903	SH	S	N	3.10	135	60	40				50	150	10				50					
2N3904	SH	S	N	3.10	135	60	40				100	300	10				100					
2N3905	SH	S	P	3.10	135	40	40				50	150	10				50					
2N3906	SH	S	P	3.10	135	40	40				100	300	10				100					
2N3910	SC	S	P	500	200	60	50				40	160	1									
2N3911	SC	S	P	500	200	60	40				60	240	1									
2N3912	SC	S	P	500	200	60	30				90		1									
2N3913	SC	S	P	400	200	60	50				40	160	1									
2N3914	SC	S	P	400	200	60	40				60	240	1									
2N3915	SC	S	P	400	200	60	30				90		1									
2N3916	AP	S	N	5W	150	150	150				40	200	150				30					
2N3917	AP	S	N	20W	150	80	40				30	120	1A				15					
2N3918	AP	S	N	20W	150	80	40				100	300	1A				30					
2N3919	SP	S	N	15W	150	120	60				40	120	2A									
2N3923	AH	S	N	8W	200	150	150				30	120	25				20					
2N3924	AHP	S	N	7W	200	36	18															
2N3925	AHP	S	N	10W	200	36	18															
2N3926	AHP	S	N	11.6W	200	36	18															
2N3927	AHP	S	N	23.2W	200	36	18															
2N3932	AH	S	N	200	200	30	20				40	150	2				50					
2N3933	AH	S	N	200	200	40	30				60	200	2				60					
2N3945	S	S	N	5W	200	70	50				40	250	150									
2N3946	SH	S	N	360	200	60	40				50	150	10				50					
2N3947	SH	S	N	360	200	60	40				100	300	10				100					
2N3948	AHP	S	N	1W	200	36	20				15	50	2									
2N3953	AH	S	N	200	200	15	12				30	360	2				40					
2N3959	SH	S	N	400	200	20	12				40	200	10				13					
2N3960	SH	S	N	400	200	20	12				40	200	10				16					
2N3961	AHP	S	N	10W	200	65	40															
2N3962	A	S	P	360	200	60	60				100	300	10				100					
2N3964	A	S	P	360	200	45	45				250	500	10				250					
2N3965	A	S	P	360	200	60	60				250	500	10				250					
2N3973	S	S	N	360	150	60	30				35	100	10									
2N3974	S	S	N	360	150	60	30				55	200	10									
2N3975	S	S	N	360	150	60	30				35	100	10									
2N3976	S	S	N	360	150	60	30				55	200	10									
2N3983	AH	S	N	200	150	30	12				30		4									
2N3984	AH	S	N	200	150	30	12				20		4									
2N3985	AH	S	N	200	150	30	12				20		4									
2N4012	AP	S	N	11.6W	200	65	40				4	40	1A									
2N4013	SH	S	N	360	200	60	40					150	100									
2N4014	SH	S	N	360	200	80	50					150	100									

TYPE	TOSHIBA	NEC	HITACHI	MITSUBISHI	MATSUSHITA	FJITSU	SONY	SANYO	NOTE
2N3859A	2SC506		2SC473						
2N3860	2SC732		2SC461	2SC620			2SC631A	2SC933FP	
2N3866									
2N3867									
2N3868									
2N3869									
2N3877	2SC506		2SC473						
2N3877A	2SC506								
2N3878									
2N3880									
2N3900	2SC732	2SC815	2SC458LG	2SC1312			2SC631A		
2N3900A	2SC732	2SC815	2SC458LG	2SC1312			2SC631A		
2N3901	2SC732	2SC815	2SC458LG	2SC1312			2SC631A		
2N3903			2SC1214	2SC1210		2SC1247A			
2N3904			2SC1214	2SC1210		2SC1247A			
2N3905				2SA696					
2N3906				2SA696		2SA555			
2N3910		2SA636							
2N3911		2SA636							
2N3912		2SA636							
2N3913		2SA636							
2N3914		2SA636							
2N3915		2SA636							
2N3916									
2N3917									
2N3918									
2N3919									
2N3923									
2N3924					2SC572				
2N3925					2SC572				
2N3926	2SC1120	2SC637		2SC703	2SC597	2SC843			
2N3927	2SC1120	2SC320				2SC842			
2N3932									
2N3933									
2N3945									
2N3946									
2N3947									
2N3948	2SC1165	2SC890		2SC908	2SC731	2SC1479			
2N3953									
2N3959									
2N3960									
2N3961		2SC598		2SC691		2SC542			
2N3962									
2N3964									
2N3965									
2N3973	2SC734		2SC317	2SC620	2SC456	2SC725		2SC933	
2N3974	2SC734		2SC317	2SC620	2SC456	2SC725		2SC933	
2N3975	2SC734		2SC317	2SC620	2SC456	2SC725		2SC933	
2N3976	2SC734		2SC317	2SC620	2SC456	2SC725		2SC933	
2N3983									
2N3984									
2N3985									
2N4012	2SC549	2SC598		2SC691		2SC542		2SC614	
2N4013									
2N4014									

GE

TYPE	USE	MATERIAL	POLARITY	MAXIMUM RATINGS					ELECTRICAL CHARACTERISTICS											OUTLINE TO.	NOTE						
				Pc 25°C (mW)	Tj (°C)	Vca (V)	Vcbo (V)	Ic (mA)	Icbo (μA)	Vce(V)	hfe		hfe	hfe (Ω)	hfe (x10)	hoe (μS)	fT (MHz)	NF (dB)	Cob (pF)			Coxtrb (ps)					
2N4026	A	S	P	500	200	60	60				40	120	100														
2N4028	A	S	P	500	200	60	60					100	300	100													
2N4030	A	S	P	800	200	60	60					40	120	100													
2N4032	A	S	P	800	200	60	60					100	300	100													
2N4034	SH	S	P	360	200	40	40					70	200	10			50										
2N4035	SH	S	P	360	200	40	40					150	300	10			150										
2N4036	S	S	P	5W	200	90	65					40	140	150													
2N4037	S	S	P	1W	200	60	40					50	250	150													
2N4040	AHP	S	N	17.5W	200	60	40					10	80	100													
2N4041	AHP	S	N	10W	200	60	40					10	80	75													
2N4043	AM	S	N	300	200	45	45					80	800	10													
2N4046	SH	S	N	800	200	50	30						150	100													
2N4047	SH	S	N	800	200	80	50						150	100													
2N4054	AP	S	N	6.25W	150	300	300						30	90	50												
2N4055	AP	S	N	6.25W	150	250	250						30	90	50												
2N4056	AP	S	N	6.25W	150	200	200						30	90	50												
2N4057	AP	S	N	6.25W	150	150	150						30	90	50												
2N4058	A	S	P	250	150	30	30					100	400	1			100										
2N4059	A	S	P	250	150	30	30					45	660	1			45										
2N4060	A	S	P	250	150	30	30					45	165	1			45										
2N4061	A	S	P	250	150	30	30					90	330	1			90										
2N4062	A	S	P	250	150	30	30					180	660	1			180										
2N4064	AP	S	N	10W	200	300	250						40	160	20										15		
2N4069	AP	S	N	1W	175	150	150						30		30											50	
2N4072	AHP	S	N	1.5W	200	40	20						10	25A												550	
2N4073	AHP	S	N	1.5W	205	40	20						10	25A												550	
2N4074	AH	S	N	400	175	40	40									400											
2N4081	AH	S	N	200		40	40					40	180	2			40									600	
2N4104	AH	S	N	300	175	60	60									1400										540	
2N4111	AP	S	N	30W		100	60					40	120	2A												70	
2N4121	AH	S	P	200	125	40	40					170		10		50										400	
2N4122	AH	S	P	200	125	40	40					150		10		150										450	
2N4123	SH	S	N	310	125	40	30					50	150	2		50										250	
2N4124	SH	S	N	310	135	30	25					120	360	2		120										300	
2N4125	SH	S	P	310	135	30	30					50	150	2		50										200	
2N4126	SH	S	P	310	135	25	25					120	360	2		120										250	
2N4127	AP	S	N	25W		60	40					10	80	200												300	
2N4128	AP	S	N	40W		60	40					10	80	200												200	
2N4134	AH	S	N	200	200	30	30									200										350	
2N4135	AH	S	N	200	200	30	30									200										425	
2N4137	SP	S	N	360	200	40	40					40	120	10												500	
2N4138	SC	S	N	300	200	30	30					50		1												20	
2N4140	AH	S	N	300	125	60	30						120	150												250	
2N4141	AH	S	N	300	125	60	30						300	150												250	
2N4142	AH	S	P	300	125	60	40						120	150												200	
2N4143	AH	S	P	300	125	60	40						300	150												200	
2N4207	SH	S	P	300	200	6	6					50	120	10												650	
2N4208	SH	S	P	300	200	12	12					30	120	10												700	
2N4209	SH	S	P	300	200	15	15					50	120	10												850	
2N4225	AP	S	N	5W		100	40					40	150	1A												150	
2N4226	AP	S	N	5W		200	60					40	150	1A												150	
2N4227	S	S	N	300	125	60	30						150	150												250	
2N4228	AH	S	P	300	125	60	40						150	150												200	
2N4231	AP	S	N	35W	200		40					25	100	1.5A												1	
2N4232	AP	S	N	36W	200		60					25	100	1.5A												1	

TYPE	TOSHIBA	NEC	HITACHI	MITSUBISHI	MATSUSHITA	FUJITSU	SONY	SANYO	NOTE
2N4026									
2N4028									
2N4030									
2N4032									
2N4034									
2N4035									
2N4036									
2N4037									
2N4040		2SC831		2SC692		2SC1058			
2N4041		2SC831		2SC692		2SC1057			
2N4043									
2N4046									
2N4047									
2N4054									
2N4055									
2N4056									
2N4057									
2N4058									
2N4059									
2N4060									
2N4061									
2N4062									
2N4064									
2N4069									
2N4072		2SC319		2SC730					
2N4073		2SC319		2SC730					
2N4074									
2N4081									
2N4104									
2N4111									
2N4121									
2N4122									
2N4123			2SC1213	2SC1210	2SC1318			2SC875	
2N4124			2SC1213	2SC1210	2SC1318			2SC875	
2N4125				2SA696					
2N4126				2SA696					
2N4127									
2N4128	2SC1077	2SC1037		2SC690					
2N4134		2SC922				2SC723	2SC1129		
2N4135		2SC922				2SC723	2SC1129		
2N4137									
2N4138		2SC1216	2SC689H					2SC933	
2N4140	2SC979			2SC302		2SC203			
2N4141	2SC979			2SC302		2SC203			
2N4142									
2N4143									
2N4207									
2N4208									
2N4209									
2N4225									
2N4226									
2N4227	2SC979			2SC302		2SC203			
2N4228									
2N4231									
2N4232									

TYPE	USE	MATERIAL	POLARITY	MAXIMUM RATINGS					ELECTRICAL CHARACTERISTICS											OUTLINE TO.	NOTE					
				Pc 25°C (mW)	Tj (°C)	V _{ce} (V)	V _{ceo} (V)	I _c (mA)	I _{ceo} (μ A)	V _{ce} (V)	min.	max.	I _c (mA)	h _{fe}	h _{ie} (Ω)	h _{re} ($\times 10^{-4}$)	h _{oe} (μ S)	f _T at I _c = I _{ce} (MHz)	NF (dB)			C _{ob} (pF)	C _{ox} (ps)			
2N4234	SP	S	P	1W	200	40	40				30	150	250				3									
2N4235	SP	S	P	1W	200	60	60				30	150	250				3									
2N4237	AP	S	P	5W	175	50	40				40	160	500	40			10									
2N4238	AP	S	P	5W	175	80	60				40	160	500	40			10									
2N4248	A	S	P	200	125	40	40										40									
2N4249	A	S	P	200	125	60	60										50									
2N4250	A	S	P	200	125	40	40										100									
2N4251	S	S	N	250	200	15	10				100		10				250									
2N4252	AH	S	N	200	175	30	18				50		2				1300									
2N4253	AH	S	N	200	175	30	18				30		2				600									
2N4254	A	S	N	200	175	30	18				50		2				600									
2N4255	A	S	N	200	125	30	18				30		2													
2N4256	A	S	N	200		30	30	100	0.1nA	30	100	500	2				200							98	GE	
2N4257	SH	S	P	200	125	6	6				30	120	10				500									
2N4258	SH	S	P	200	125	12	12				30	120	10				700									
2N4259	AH	S	N	175	175	40	30										70									
2N4260	SH	S	P	200	200	15	15				30	150	10	16			1500									
2N4261	SH	S	P	200	200	5	15				30	150	15A	20			2000									
2N4262	AP	S	N	1.5W		25	10				75		300				600									
2N4263	AP	S	N	1.5W		25	10				75		300				800									
2N4264	S	S	N	310	135	30	15				4	160	10				300									
2N4265	SH	S	P	310	135	30	12				100	400	15				300									
2N4271	AP	S	N	5W		175	140				20	140	200				20									
2N4274	SH	S	N	280	125	30	12				18		100				400									
2N4275	SH	S	N	280	125	40	15				18		100				400									
2N4284	A	S	P	250	165	25	25				600		1													
2N4285	A	S	P	250	165	35	35				600		1													
2N4286	A	S	N	250	150	30	25										600									
2N4287	A	S	N	250	150	45	45										600									
2N4288	A	S	P	250	150	30	25										600									
2N4289	A	S	P	250	150	60	40										600									
2N4290	A	S	P	250	150	30	20										600									
2N4291	A	S	P	250	150	40	30										600									
2N4292	A	S	N	200	150	30	15				20		3				600									
2N4293	A	S	N	200	150	30	15										60									
2N4294	SH	S	N	200	150	30	12				30	120	10				400									
2N4295	SH	S	N	200	150	40	15				40	120	10				500									
2N4296	SP	S	N	20W		350	250				50	150	50				20									
2N4297	AP	S	N	20W		350	250				75	300	50				20									
2N4307	AP	S	N	1.5W		100	60				50	150	1A													
2N4308	AP	S	N	4W		100	60				50	150	1A													
2N4311	AP	S	N	1.5W		100	60				40	120	1A													
2N4312	AP	S	N	4W		100	60				40	120	1A													
2N4314	AP	S	P	1W		90	65				50	250	150				200									
2N4347	AP	S	N	100W	200	140	120	5A			15	60	2A											3	GE	
2N4348	AP	S	N	120W	200	140	120	10A			15	60	5A											3	GE	
2N4350	AP	S	N	7W		65	40				10	200	350				300									
2N4354	A	S	P	350	125	60	60				25		100				500									
2N4355	A	S	P	350	125	60	60				60		100				500									
2N4359	A	S	P	360	200	45	45				50	600	1				50									
2N4383	AH	S	N	800	200	40	30										1000									
2N4384	AH	S	N	500	200	40	30										1000									
2N4385	AH	S	N	800	200	40	30										1000									
2N4386	AH	S	N	500	200	40	30										1000									
2N4387		S	P	20W	200	40	40				25	100	500													

TYPE	TOSHIBA	NEC	HITACHI	MITSUBISHI	MATSUSHITA	FUJITSU	SONY	SANYO	NOTE
2N4234		2SA635	2SA715	2SA624					
2N4235		2SA635		2SA624					
2N4237									
2N4238									
2N4248				2SA696		2SA558			
2N4249				2SA697					
2N4250				2SA696		2SA558			
2N4251									
2N4252	2SC384	2SC922				2SC724			
2N4253	2SC384	2SC922				2SC724			
2N4254	2SC384	2SC922				2SC724			
2N4255	2SC384	2SC922				2SC714			
2N4256	2SC400		2SC458	2SC713		2SC724			
2N4257									
2N4258									
2N4259									
2N4260									
2N4261									
2N4262									
2N4263									
2N4264									
2N4265									
2N4271									
2N4274									
2N4275									
2N4284									
2N4285									
2N4286	2SC752Ⓒ	2SC1274	2SC689Ⓓ	2SC619		2SC724		2SC933	
2N4287	2SC734	2SC1274		2SC620		2SC725			
2N4288									
2N4289									
2N4290									
2N4291									
2N4292	2SC383	2SC922		2SC763			2SC1129		
2N4293	2SC383	2SC922		2SC763			2SC1129		
2N4294									
2N4295									
2N4296									
2N4297									
2N4307									
2N4308									
2N4311									
2N4312									
2N4314									
2N4347	2SD118	2SD218				2SD177	2SD88A-2		
2N4348							2SD340		
2N4350	2SC549	2SC598		2SC691		2SC542			
2N4354									
2N4355									
2N4359									
2N4383	2SC503	2SC960	2SC480	2SC306	2SC696				
2N4384	2SC503	2SC960	2SC480	2SC306	2SC696	2SC200			
2N4385	2SC503	2SC960	2SC480	2SC306	2SC696				
2N4386	2SC503	2SC960	2SC480	2SC306	2SC696	2SC200			
2N4387									

TYPE	USE	MATERIAL	POLARITY	MAXIMUM RATINGS						ELECTRICAL CHARACTERISTICS							OUTLINE TO.	NOTE								
				Pc 25°C (mW)	Tj (°C)	Vcb (V)	Vcbo (V)	Ic (mA)	Icbo (μA)	h _{FE}			h _{FE}	h _{ie} (Ω)	h _{re} (×10 ⁻³)	hoe (μS)			f _r *f _{CE} *f _{COB} (MHz)	NF (dB)	C _{ob} (pF)	C _{ocrb} (ps)				
2N4388		S P	20W	200	60	60					25	100	500													
2N4389	SH	S N	200	125	12	12					30	80	10	4												
2N4400	SH	S N	310	135	60	40					50	150	150	20									200			
2N4401	SH	S N	310	135	60	40					100	300	150	40										250		
2N4402	SH	S P	310	135	40	40					50	150	150	30										150		
2N4403	SH	S P	310	135	40	40					100	300	150	60										200		
2N4409	S	S N	310	135	80	50					60	400	1													
2N4410	S	S N	310	135	120	80					60	400	1													
2N4412	AH	S P	600	200	40	30																		100		
2N4413	AH	S P	400	200	40	30																		100		
2N4414	AH	S P	600	200	40	30																		100		
2N4415	AH	S P	400	200	40	30																		100		
2N4418	S	S N	250	125	40	40					40	120	10											500		
2N4419	S	S N	250	125	30	30					30		10											400		
2N4420	S	S N	250	125	40	40					30	120	30											350		
2N4421	S	S N	250	125	30	30					25		30											330		
2N4423	S	S N	250	125	12	12					40	150	30											440		
2N4424	S	S N	360	150	40	40	500	0.03	40	180	2		180											98	GE	
2N4425	S	S N	360	150	40	40	500	0.03	40	180	2		180											98	GE	
2N4428	AP	S N	3.5W		55	35					20	220	50											700		
2N4429	AP	S N	5W		55	35					20	200	50												700	
2N4430	AP	S N	10W		55	40					20	200	100											600		
2N4432	AH	S N	600		50	30					40	130	6	45												
2N4432A	AH	S N	600		50	30					80	150	6	90												
2N4436	AHP	S N	200	125	60	30					40	120	150											250		
2N4437	AHP	S N	200	125	60	30					100	300	150											250		
2N4440	AP	S N	11.6W		65	40					10	200	125											400		
2N4452	S	S P	350	200	45	45					115	300	50	135										200		
2N4453	S	S P	300			18					40		30											400		
2N4872	SH	S P	700	200	12	12					50	120	10	9												
2N4873	SH	S N	360	200	40	15					110	150	10	7												
2N4874	AH	S N	720	175	30	20								200										900		
2N4875	AH	S N	720	175	40	25								200										800		
2N4876	AH	S N	720	175	40	30								200										650		
2N4877	AP	S N	10W	200		60					20	200	4A											4		
2N4890	S	S P	1W		60	40					50	250	150	5												
2N4898	AP	S P	25W	200	40	40					20	100	500	25										3		
2N4899	AP	S P	25W	200	60	60					20	100	500	25										3		
2N4910	AP	S N	25W	200	40	40					20	100	500	25										3		
2N4911	AP	S N	25W	200	60	60					20	100	500	25										3		
2N4916	SH	S P	500	125	30	30					70	200	10											400		
2N4917	SH	S P	500	125	30	30					150	300	10											450		
2N4918	AP	S P	30W	150	40	40					20	100	500	25										3		
2N4919	AP	S P	30W	150	60	60					20	100	500	25										3		
2N4921	AP	S N	30W	150	40	40					20	100	500	25										3		
2N4922	AP	S N	30W	150	60	60					20	100	500	25										3		
2N4923	AP	S N	30W	150	80	80					20	100	500	25										3		
2N4924	AH	S N	1W	175	100	100					40	200	150											100		
2N4925	AH	S N	1W	175	150	150					40	200	150											100		
2N4926	AH	S N	1W	175	200	200					20	200	30	25										300		
2N4927	AH	S N	1W	175	250	250					20	200	30	25										300		
2N4944	A	S N	600	125	80	40					40	100	150											60		
2N4945	A	S N	600	125	80	60					40	100	150											60		
2N4946	A	S N	600	125	80	40					100	300	150											60		
2N4951	A	S N	360	150	60	30					60	200	150											250		

TYPE	TOSHIBA	NEC	HITACHI	mitsubishi	MATSUSHITA	FUJITSU	SONY	SANYO	NOTE
2N4388									
2N4389									
2N4400	2SC734			2SC1211	2SC1318	2SC1247		2SC875	
2N4401	2SC734			2SC1211	2SC1318	2SC1247		2SC875	
2N4402				2SA696					
2N4403				2SA696					
2N4409	2SC506	2SC1278	2SC857	2SC869	2SC1033				
2N4410	2SC506	2SC1278	2SC857	2SC869	2SC1033				
2N4412		2SA636	2SA715	2SA624					
2N4413		2SA636	2SA715	2SA624					
2N4414		2SA636	2SA715	2SA624					
2N4415		2SA636	2SA715	2SA624					
2N4418									
2N4419									
2N4420									
2N4421									
2N4423									
2N4424	2SC1382				2SC1318	2SC1247			
2N4425	2SC1382				2SC1318	2SC1247			
2N4428				2SC976					
2N4429				2SC976					
2N4430		2SC892		2SC975	2SC1075				
2N4432	2SC998			2SC741	2SC456				
2N4432A	2SC998			2SC741	2SC456				
2N4436	2SC998			2SC741	2SC456				
2N4437	2SC998			2SC741	2SC456				
2N4440				2SC692					
2N4452									
2N4453									
2N4872									
2N4873									
2N4874	2SC503			2SC976					
2N4875	2SC503			2SC976					
2N4876	2SC503			2SC976					
2N4877									
2N4890									
2N4898									
2N4899									
2N4910									
2N4911									
2N4916									
2N4917									
2N4918									
2N4919									
2N4921									
2N4922									
2N4923									
2N4924									
2N4925									
2N4926									
2N4927									
2N4944				2SC1211	2SC1318			2SC875	
2N4945				2SC1211					
2N4946				2SC1211	2SC1318			2SC875	
2N4951									

GE

TYPE	USE	MATERIAL	POLARITY	MAXIMUM RATINGS											ELECTRICAL CHARACTERISTICS									OUTLINE TO	NOTE
				Pc 25°C (mW)	Tj (°C)	Vcb (V)	Vcbo (V)	Ic (mA)	Icbo		hrr		hfe	hie (Ω)	hre (×10)	hoe (μs)	fr ***f _{0.5} (MHz)	NF (dB)	Cob (pF)	Cox/β ₀ (ps)					
									(μA)	V _{cb} (V)	min.	max.									Ic (mA)				
2N4952	A	S	N	360	150	60	30				100	300	150					250							
2N4953	A	S	N	360	150	60	30				200	600	150					250							
2N4954	A	S	N	360	150	40	30				60	600	150					250							
2N4957	A	S	P	200	200	30	30				20	40	2					1200							
2N4958	A	S	P	200	200	30	30				20	40	2					1000							
2N4959	A	S	P	200	200	30	30				20	40	2					1000							
2N4964	A	S	P	200		50	40				30	120	0.01	40											
2N4965	A	S	P	200		50	40				80	400	0.01	100											
2N4966	A	S	N	200		50	40				40	200	0.01	40											
2N4967	A	S	N	200		50	40				100	600	0.01	100											
2N4968	A	S	N	200		30	25				40	200	0.01	40											
2N4969	SH	S	N	200		50	30				40	120	150												
2N4970	SH	S	N	200		50	30				100	350	150												
2N4971	SH	S	P	200		50	40				40	120	150												
2N4972	SH	S	P	200		50	40				100	300	150												
2N4976	AHP	S	N	5W		55	30				20	250	50				1000								
2N4994	AH	S	N	200		60	45	30	0.1	30	40	160	10						18	GE					
2N4995	AH	S	N	200		60	45	30	0.1	30	100	400	10						18	GE					
2N4996	AH	S	N	200		30	18				50		2												
2N4997	AH	S	N	200		30	18				30	150	2												
2N5022	SH	S	P	1W		50	50				25	100	500												
2N5023	SH	S	P	1W		30	30				40	100	500												
2N5027	S	S	N	320	120		30				50	150	150												
2N5028	S	S	N	320	120		30				100	300	150												
2N5029	S	S	N	320	120		15				40	120	10												
2N5030	S	S	N	320	120		12				30		10												
2N5031	AH	S	N	200		15	10				25	300	1												
2N5032	AH	S	N	200		15	40				25	300	1												
2N5040	A	S	P	300	125	25	25				30	60	150				100								
2N5041	A	S	P	300	125	40	40				40	150	150				80								
2N5042	A	S	P	800	200	40	40				40	150	150				100								
2N5053	AH	S	N	200	200	30	15				25	150	2				1300								
2N5054	AH	S	N	200	200	30	15				25	150	2				1300								
2N5055	SH	S	P	200	125	12	12				30	100	30												
2N5056	SH	S	P	360	200	15	15				30	100	30												
2N5058		S	N	1W	200	300	300				35	150	30												
2N5059		S	N	1W	200	250	250				30	150	30												
2N5065	SH	S	N	2.5W	200	25	15				50	120	300				550								
2N5066	SC	S	N	400		30	20										5								
2N5079	A	S	N	1.8W		60	30				100	300	150				400								
2N5080	A	S	N	1.8W		60	30				200	500	150				500								
2N5081	AH	S	N	1.2W		70	50				100	400	1	100			600								
2N5082	AH	S	N	1.2W		60	30				100	400	1	100			600								
2N5086	A	S	P	310	135	50	50				150	500	0.1	250			40								
2N5087	A	S	P	310	135	50	50				250	800	0.1	250			40								
2N5088	A	S	N	310	135	35	35				300	900	0.1	350			50								
2N5089	A	S	N	310	135	30	25				400	1200	0.1	450			50								
2N5106	A	S	N	800	200	60	30				100	300	150				250								
2N5107	A	S	N	360	200	60	30				100	300	150				250								
2N5112	AP	S	P	34W	175	40	40				15	60	500	10			1								
2N5127	A	S	N	200	125	20	12				15	300	2	12											
2N5128	A	S	N	200	125	15	12				35	350	50												
2N5130	A	S	N	200	125	30	12				15	250	8	12											
2N5131	A	S	N	200	125	20	15				30	500	10	25											
2N5132	A	S	N	200	125	20	20				30	400	10	20											

TYPE	TOSHIBA	NEC	HITACHI	mitsubishi	MATSUSHITA	FUJITSU	SONY	SANYO	NOTE
2N4952									
2N4953									
2N4954									
2N4957									
2N4958									
2N4959									
2N4964				2SA696		2SA558			
2N4965				2SA696		2SA558			
2N4966	2SC506	2SC1278	2SC857	2SC869	2SC1033				
2N4967	2SC506	2SC1278	2SC857	2SC869	2SC1033				
2N4968				2SC711				2SC933FP	
2N4969				2SC1210	2SC1318	2SC1247A		2SC875	
2N4970				2SC1210	2SC1318	2SC1247A		2SC875	
2N4971									
2N4972									
2N4976		2SC831		2SC976		2SC1058			
2N4994		2SC839	2SC463				2SC634	2SC933FP	
2N4995		2SC839	2SC463				2SC634	2SC933FP	
2N4996									
2N4997									
2N5022									
2N5023									
2N5027									
2N5028									
2N5029									
2N5030									
2N5031									
2N5032									
2N5040									
2N5041									
2N5042									
2N5053									
2N5054									
2N5055									
2N5056									
2N5058									
2N5059									
2N5065									
2N5066									
2N5079									
2N5080									
2N5081									
2N5082									
2N5086									
2N5087									
2N5088	2SC733	2SC900		2SC871	2SC644		2SC632		
2N5089	2SC733	2SC900		2SC871	2SC644		2SC632		
2N5106									
2N5107									
2N5112									
2N5127	2SC732	2SC838	2SC461	2SC711			2SC631A	2SC933FP	
2N5128			2SC1213	2SC1210	2SC1318	2SC1247A			
2N5130	2SC387A	2SC922				2SC723	2SC1129		
2N5131		2SC1216		2SC619		2SC724		2SC933	
2N5132	2SC732	2SC838	2SC461	2SC711			2SC631A	2SC933FP	

TYPE	USE	MATERIAL	POLARITY	MAXIMUM RATINGS								ELECTRICAL CHARACTERISTICS										OUTLINE TO.	NOTE				
				Pc 25°C (mW)	Tj (°C)	Vcs (V)	Vcto (V)	Ic (mA)	Icbo		hfe		hfe	hie (Ω)	hre (x10)	hoe (μA)	Tr *f _{ce} **f _{z0} (MHz)	NF (dB)	Cob (pF)	Coxrbb (ps)							
									(μA)	V _{ce} (V)	min.	max.									Ic (mA)						
2N5133	A	S	N	200	125	20	18				60	1000	1	50													
2N5134	SH	S	N	200	125	20	10				20	150	10														
2N5135	A	S	N	300	125	30	25				50	600	10														
2N5136	A	S	N	220	125	30	20				20	400	150														
2N5137	A	S	N	300	125	30	20				20	400	150														
2N5138	A	S	P	200	125	30	20				50	800	0.1	40													
2N5139	SH	S	P	200	125	20	20				40		!														
2N5142	SH	S	P	300	125	20	20				30		50														
2N5143	SH	S	P	200	125	20	20				30		50														
2N5160	AHP	S	P	5W		60	40				10		50			500											
2N5161	AHP	S	P	20W		60	40				10		250														
2N5172	A	S	N	200		25	25	100	0.1	25	100	500	10	100			200							98	GE		
2N5174	A	S	N	200		90	75	25	0.5	60	40	600	10	40											98	GE	
2N5175	A	S	N	200		130	100	25	0.5	60	55	160	10	55											98	GE	
2N5176	A	S	N	200		130	100	25	0.5	60	140	300	10	140												98	GE
2N5189	SH	S	N	1W		60	55				15		!														
2N5190	AP	S	N	40W	150	40	40				25	100	1.5A	20													
2N5191	AP	S	N	40W	150	60	60				25	100	1.5A	20													
2N5193	AP	S	P	40W	150	40	40				25	100	1.5A	20													
2N5194	AP	S	P	40W	150	60	60				25	100	1.5A	20													
2N5209	A	S	N	310		50	50				100	300	0.1	150													
2N5210	A	S	N	310		50	50				200	600	0.1	250													
2N5213	AHP	S	N	7.5W	200	70	40				10	80	200			350											
2N5219	A	S	N	310		20	15				35	500	2	35													
2N5220	A	S	N	310		15	15				30	600	50	20													
2N5221	A	S	P	310		15	15				30	600	50	30													
2N5222	A	S	N	310		20	15				20	1500	4	20													
2N5223	A	S	N	310		25	20				50	800	2	50													
2N5224	SH	S	N	310		25	12				40	400	10														
2N5225	A	S	N	310		25	25				30	600	50	30													
2N5226	A	S	P	310		25	25				30	600	50	30													
2N5227	A	S	P	310		30	30				50	700	2	10													
2N5232	A	S	N	330	125	70	50	100	0.03	50	250	500	2	250							1KHZ 1.3				98	GE	
2N5232A	A	S	N	330	125	70	50	100	0.03	50	250	500	2	250							1KHZ 1.3				98	GE	
2N5236	AH	S	N	1W	200	40	20				30	120	50			500											
2N5242	SH	S	P	500			20				25	100	500			170											
2N5243	SH	S	P	500			30				25	100	500			170											
2N5244	SH	S	P	1W			40				150	300	10			450											
2N5249	A	S	N	330	125	70	50	100	0.03	50	400	800	2	400							1KHZ 3				98	GE	
2N5249A	A	S	N	330	125	70	50	100	0.03	50	400	800	2	400							1KHZ 3				98	GE	
2N5252	A	S	N	7W		300	300				40	120	100			30											
2N5253	A	S	N	7W		300	300				80	250	100			30											
2N5262	SH	S	N	1W		75	50				35		100														
2N5272	SH	S	N	360		40	40				100	400	10			500											
2N5276	S	S	N	360		25	15				30	90	1			600											
2N5279	AH	S	N	5W		400					40	160	20			15											
2N5292	SH	S	P	1W	200		12				40	100	30			800											
2N5295	AP	S	N	360	150	60	50				30	120	1A	20													
2N5296	AP	S	N	360	150	60	50				30	120	1A	20													
2N5297	AP	S	N	360	150	60	70				20	80	1.5A	25													
2N5298	AP	S	N	360	150	80	70				20	80	1.5A	25													
2N5305	AL	S	N	450		25	25	300	0.1	25	2K	20K	2	2K			60										
2N5306	AL	S	N	400		25	25	300	0.1	25	7K	70K	2	7K			60										
2N5306A	AL	S	N	400		25	25	300	0.1	25	7K	70K	2	7K			60										
2N5307	AL	S	N	400		40	40	300	0.1	40	2K	20K	2	2K			60										

TYPE	TOSHIBA	NEC	HITACHI	MITSUBISHI	MATSUSHITA	FUJITSU	SONY	SANYO	NOTE
2N5133	2SC732	2SC838	2SC461	2SC711			2SC631A	2SC933FP	
2N5134	2SC979		2SC907H	2SC300		2SC203	2SC1128	2SC423	
2N5135			2SC1213	2SC1210	2SC1318	2SC1247A			
2N5136			2SC1213	2SC1210	2SC1318	2SC1247A			
2N5137			2SC1213	2SC1210	2SC1318	2SC1247A			
2N5138				2SA696		2SA558			
2N5139				2SA696		2SA558			
2N5142				2SA696		2SA558			
2N5143				2SA696		2SA558			
2N5160									
2N5161									
2N5172	2SC1000		2SC458	2SC712		2SC1372	2SC633A	2SC933FP	
2N5174	2SC506	2SC1279	2SC857	2SC869	2SC1033				
2N5175	2SC506	2SC1279	2SC857	2SC869	2SC1033				
2N5176	2SC506	2SC1279	2SC857	2SC869	2SC1033				
2N5189									
2N5190									
2N5191									
2N5193									
2N5194									
2N5209									
2N5210									
2N5213									
2N5219									
2N5220									
2N5221									
2N5222									
2N5223									
2N5224									
2N5225									
2N5226									
2N5227									
2N5232	2SC979		2SC984	2SC714		2SC205			
2N5232A	2SC979		2SC984	2SC714		2SC205			
2N5236									
2N5242									
2N5243									
2N5244									
2N5249	2SC979		2SC984	2SC714		2SC205			
2N5249A	2SC979		2SC984	2SC714		2SC205			
2N5252									
2N5253									
2N5262									
2N5272									
2N5276									
2N5279									
2N5292									
2N5295									
2N5296									
2N5297									
2N5298									
2N5305									
2N5306									
2N5306A									
2N5307									

GE

TYPE	USE	MATERIAL	POLARITY	MAXIMUM RATINGS									ELECTRICAL CHARACTERISTICS										OUTLINE TO.	NOTE
				Pc 25°C (mW)	Tj (°C)	Vce (V)	Vcco (V)	Ic (mA)	Icbo		h _{FE}		hfe	hie (Ω)	hre (x10)	hoe (Ω)	f _T MHz	NF (dB)	Cob (pF)	Cox _{bb} (ps)				
									(μA)	V _{CE} (V)	min.	max.									Ic (mA)			
2N5308	AL	S	N	400		40	40	300	0.1	40	7K	70K	2	7K			60						GE	
2N5308A	AL	S	N	400		40	40	300	0.1	40	7K	70K	2	7K			60						GE	
2N5309	A	S	N	330		70	50	100	0.01	50	60	120	0.1	66								98	GE	
2N5310	A	S	N	330		70	50	100	0.01	50	100	300	0.1	10								98	GE	
2N5311	A	S	N	330		70	50	100	0.01	50	250	500	0.1									98	GE	
2N5321	SP	S	N	10W	200	75	50				40	250	500			50								
2N5322	SP	S	P	10W	200	100	75				30	130	500			50								
2N5323	SP	S	P	10W	200	75	50				40	250	500			50								
2N5334	SP	S	N	6W	200	60	60				30	150	1A			40								
2N5354	A	S	P	360	125	25	25	350	0.1	25	40	120	50	32		250						98	GE	
2N5355	A	S	P	360	125	25	25	350	0.1	25	100	300	50	80		250						98	GE	
2N5356	A	S	P	360	125	25	25	350	0.1	25	250	500	50	200		250						98	GE	
2N5365	A	S	P	360	125	40	40	700	0.1	40	40	120	50	32		250						98	GE	
2N5366	A	S	P	360	125	40	40	700	0.1	40	100	300	50	80		250						98	GE	
2N5367	A	S	P	360	125	40	40	700	0.1	40	250	500	50	200		250						98	GE	
2N5368	A	S	N	360	150	60	30	500	0.05	40	60	200	150			250						18	GE	
2N5369	A	S	N	360	150	60	30	500	0.05	40	100	300	150			250						18	GE	
2N5370	A	S	N	360	150	60	30	500	0.05	40	200	600	150			250						18	GE	
2N5371	A	S	N	360	150	40	30	500	0.05	40	60	600	150			250						18	GE	
2N5372	A	S	P	360	150	60	30	500	0.05	40	40	120	150			150						18	GE	
2N5373	A	S	P	360	150	60	30	500	0.05	40	100	300	150			150						18	GE	
2N5374	A	S	P	360	150	60	30	500	0.05	40	200	400	150			150						18	GE	
2N5375	A	S	P	360	150	40	30	500	0.05	40	40	400	150			150						18	GE	
2N5376	A	S	N	360	150	60	30				100	500	0.01	120		300								
2N5377	A	S	N	360	150	60	30				40	200	0.01	100		300								
2N5378	A	S	P	360	150	40	30				100	500	0.01	120		200								
2N5379	A	S	P	360	150	40	30				40	200	0.01	100		200								
2N5417	SH	S	N	500		40	35				80	250	150			250								
2N5418	A	S	N	360	125	25	25	500	0.1	25	40	120	50	25		250						98	GE	
2N5419	A	S	N	360	125	25	25	500	0.1	25	100	300	50	70		250						98	GE	
2N5420	A	S	N	360	125	25	25	500	0.1	25	250	500	50	150		250						98	GE	
2N5421	AHP	S	N	3W		36	18				10	60	100			300								
2N5422	AHP	S	N	5W		36	18				10	60	500			300								
2N5423	AHP	S	N	12W		36	18				20	70	1A			300								
2N5424	AHP	S	N	20W		36	18				20	100	2A			250								
2N5447	A	S	N	360		40	25	200	0.1	20	60	300	50									18	GE	
2N5448	A	S	N	360		50	30	200	0.1	20	30	150	50									18	GE	
2N5449	A	S	N	360		50	30	800	0.1	20	100	300	50									18	GE	
2N5450	A	S	N	360		50	30	800	0.1	20	50	150	50									18	GE	
2N5451	A	S	N	360		50	40	800	0.1	20	30	600	50									18	GE	
2N5455	SH	S	P	340	200	15	15				30	120	30			450								
2N5456	SH	S	P	340	200	25	25				30	120	30			450								
2N5471	AP	S	N	5W		50	30				20		50											
2N5482	AHP	S	N	10W		50	30				20		50											
2N5483	AHP	S	N	20		45	30				20		100											
2N5489	AP	S	N		200	100	100				15	50	40A	10										
2N5590	AP	S	N	30W		36	18				5		250			200								
2N5597	AP	S	P	20W	200	80	60				70	200	1A	50		60								
2N5598	AP	S	N	20W	200	80	60				70	200	1A	50		60								
2N5606	AP	S	N	25W	200	80	60				70	200	2.5A	50		70								
2N5614	AP	S	N	58W	200	80	60				70	200	2.5A	50		70								
2N5637	A	S	N	30W		60	35				5		500			400								
2N5642	A	S	N	30W		65	35				5		200			250								
2N5644	AP	S	N	3.5W		36	18				15		100			400								
2N5645	AP	S	N	12W		36	18				15		500			400								

TYPE	TOSHIBA	NEC	HITACHI	mitsubishi	MATSUSHITA	FUJITSU	SONY	SANYO	NOTE
2N5308									
2N5308A									
2N5309	2SC979		2SC984	2SC714		2SC205			
2N5310	2SC979		2SC984	2SC714		2SC205			
2N5311	2SC979		2SC984	2SC714		2SC205			
2N5321									
2N5322									
2N5323									
2N5334									
2N5354		2SA643			2SA719				
2N5355		2SA643			2SA719				
2N5356		2SA643			2SA719				
2N5365		2SA571	2SA537H		2SA546				
2N5366		2SA571	2SA537H		2SA546				
2N5367		2SA571	2SA537H		2SA546				
2N5368	2SC495				2SC1347	2SC1247			
2N5369	2SC495				2SC1347	2SC1247			
2N5370	2SC495				2SC1347	2SC1247			
2N5371	2SC495				2SC1347	2SC1247			
2N5372		2SA607			2SA546	2SA580			
2N5373		2SA607			2SA546	2SA580			
2N5374		2SA607			2SA546	2SA580			
2N5375		2SA607			2SA546	2SA580			
2N5376									
2N5377									
2N5378									
2N5379									
2N5417									
2N5418	2SC496			2SC1209	2SC1346	2SC1246A			
2N5419	2SC496			2SC1209	2SC1346	2SC1246A			
2N5420	2SC496			2SC1209	2SC1346	2SC1246A			
2N5421		2SC891		2SC910	2SC731				
2N5422				2SC910					
2N5423				2SC702					
2N5424	2SC1121			2SC702					
2N5447		2SC1216	2SC321(H)	2SC703		2SC131		2SC1175	
2N5448		2SC1216			2SC1318			2SC1175	
2N5449		2SC97A	2SC480			2SC1150			
2N5450		2SC97A	2SC480			2SC1150			
2N5451		2SC97A	2SC480			2SC1150			
2N5455									
2N5456									
2N5471									
2N5482									
2N5483									
2N5489									
2N5590									
2N5597									
2N5598									
2N5606									
2N5614									
2N5637									
2N5642									
2N5644				2SC909	2SC731				
2N5645	2SC1121	2SC892		2SC975	2SC1075				

TYPE	USE	MATERIAL	POLARITY	MAXIMUM RATINGS							ELECTRICAL CHARACTERISTICS										OUTLINE TO.	NOTE					
				Pc 25°C (mW)	Tj (°C)	Vce (V)	Vcvo (V)	Ic (mA)	Icso (μA)		hFE		hfe	hie (Ω)	hre (×10)	hoe (μS)	fr = fce = fzb (MHz)	NF (dB)	Cob (pF)	Coxbb (ps)							
									μA	Vgs(V)	min.	max.											Ic (mA)				
2N5646	AP	S	N	30W		36	18				15	1A						400									
2N5650	AH	S	N	150		20	15				30	300	300					2000									
2N5651	AH	S	N	150		20	15				30	300	300					2000									
2N5652	AH	S	N	150		20	15				30	300	300					2000									
2N5655	AP	S	N	20W	150	275	250				30	250	250	20													
2N5656	AP	S	N	20W	150	325	300				30	250	100	20													
2N5660	SP	S	N		200	250	200				40	150	500					20									
2N5661	SP	S	N		200	400	300				40	150	500					20									
2N5662	SP	S	N		200	250	200				40	150	500					20									
2N5663	SP	S	N		200	400	300				40	150	500					20									
2N5682	AP	S	N	10W	200	120	120				40	150	250	40				30									
2N5687	AP	S	N	5W		40	20				15	50															
2N5688	AP	S	N	10W		40	20				15	50															
2N5689	AP	S	N	25W		60	40				15	100															
2N5690	AP	S	N	50W		50	30				10	100															
2N5697	AP	S	N	3.5W		40	18				30	40															
2N5698	AP	S	N	5W		40	18				30	40															
2N5699	AP	S	N	10W		40	18				15	50															
2N5700	AP	S	N	35W		40	18				30	50															
2N5701	AP	S	N	35W		40	18				30	50															
2N5703	AP	S	N	750		40	18				15	50															
2N5704	AP	S	N	25W		40	18				15	50															
2N5705	AP	S	N	44W		36	18				15	100															
2N5710	AP	S	N	3.5W		40	20				20	10															
2N5712	AP	S	N	25W		60	40				10	100															
2N5713	A	S	N	45W		60	40				10	10															
2N5764	AH	S	N	10W		55	25				20	100															
2N5765	AH	S	N	19W		55	25				20	100															
2N5766	AH	S	N	5W		55	25				20	50															
2N5767	AH	S	N	10W		55	25				20	100															
2N5768	AH	S	N	20W		55	25				20	100															
2N5782	AP	S	P	10W	200	65	65				4	3.2A	25					8									
2N5783	AP	S	P	10W	200	45	45				4	3.2A	25					8									
2N5785	AP	S	N	10W	200	65	65				4	3.2A	25					2.5									
2N5786	AP	S	N	10W	200	45	45				4	3.2A	25					2.5									
2N5810	A	S	N	500	135	35	25	750	0.1	25	60	200	2					100						18		GE	
2N5811	A	S	N	500	135	35	25	750	0.1	25	60	200	2					100						18		GE	
2N5812	A	S	N	500	135	35	25	750	0.1	25	150	500	2					135						18		GE	
2N5813	A	S	P	500	135	35	25	750	0.1	25	150	500	2					135						18		GE	
2N5814	A	S	N	500	135	50	40	750	0.1	25	60	100	2					100						18		GE	
2N5815	A	S	P	500	135	50	40	750	0.1	25	60	120	2					100						18		GE	
2N5816	A	S	N	500	135	50	40	750	0.1	25	100	200	2					120						18		GE	
2N5817	A	S	P	500	135	50	40	750	0.1	25	100	200	2					120						18		GE	
2N5818	A	S	N	500	135	50	40	750	0.1	25	150	300	2					135						18		GE	
2N5819	A	S	P	500	135	50	40	750	0.1	25	150	300	2					135						18		GE	
2N5820	A	S	N	500	135	70	60	750	0.1	25	60	120	2					100						18		GE	
2N5821	A	S	P	500	135	70	60	750	0.1	25	60	120	2					100						18		GE	
2N5822	A	S	N	500	135	70	60	750	0.1	25	100	200	2					120						18		GE	
2N5823	A	S	P	500	135	70	60	750	0.1	25	100	200	2					120						18		GE	
2N5824	A	S	N	360	125	50	40	100	0.05	40	60	120	2	60				90					65	18		GE	
2N5825	A	S	N	360	125	50	40	100	0.05	40	100	200	2	100				90					65	18		GE	
2N5826	A	S	N	360	125	50	40	100	0.05	40	150	300	2	150				90					65	18		GE	
2N5827	A	S	N	360	125	50	40	100	0.05	40	250	500	2	250				90					65	18		GE	
2N5828	A	S	N	360	125	50	40	100	0.05	40	400	800	2	400				90					65	18		GE	
2N5835	SH	S	N	200	125	15	10				25	10															

TYPE	TOSHIBA	NEC	HITACHI	MITSUBISHI	MATSUSHITA	FUJITSU	SONY	SANYO	NOTE
2N5646									
2N5650									
2N5651									
2N5652									
2N5655									
2N5656									
2N5660									
2N5661									
2N5662									
2N5663									
2N5682									
2N5687									
2N5688									
2N5689									
2N5690									
2N5697									
2N5698									
2N5699									
2N5700									
2N5701									
2N5703									
2N5704									
2N5705									
2N5710									
2N5712									
2N5713									
2N5764									
2N5765									
2N5766									
2N5767									
2N5768									
2N5782									
2N5783									
2N5785									
2N5786									
2N5810		2SC97A	2SC480			2SC1150			
2N5811		2SC97A	2SC480			2SC1150			
2N5812		2SC97A	2SC480			2SC1150			
2N5813	2SA682	2SA717				2SA580			
2N5814		2SC97A	2SC480			2SC1150			
2N5815	2SA682	2SA717				2SA580			
2N5816		2SC97A	2SC480			2SC1150			
2N5817	2SA682	2SA717				2SA580			
2N5818		2SC97A	2SC480			2SC1150			
2N5819	2SA682	2SA717				2SA580			
2N5820		2SC97A	2SC480			2SC1150			
2N5821	2SA682	2SA717				2SA580			
2N5822		2SC97A	2SC480			2SC1150			
2N5823	2SA682	2SA717				2SA580			
2N5824	2SC1382	2SC1008	2SC1345	2SC1313					
2N5825	2SC1382	2SC1008	2SC1345	2SC1313					
2N5826	2SC1382	2SC1008	2SC1345	2SC1313					
2N5827	2SC1382	2SC1008	2SC1345	2SC1313					
2N5828	2SC1382	2SC1008	2SC1345	2SC1313					
2N5835									

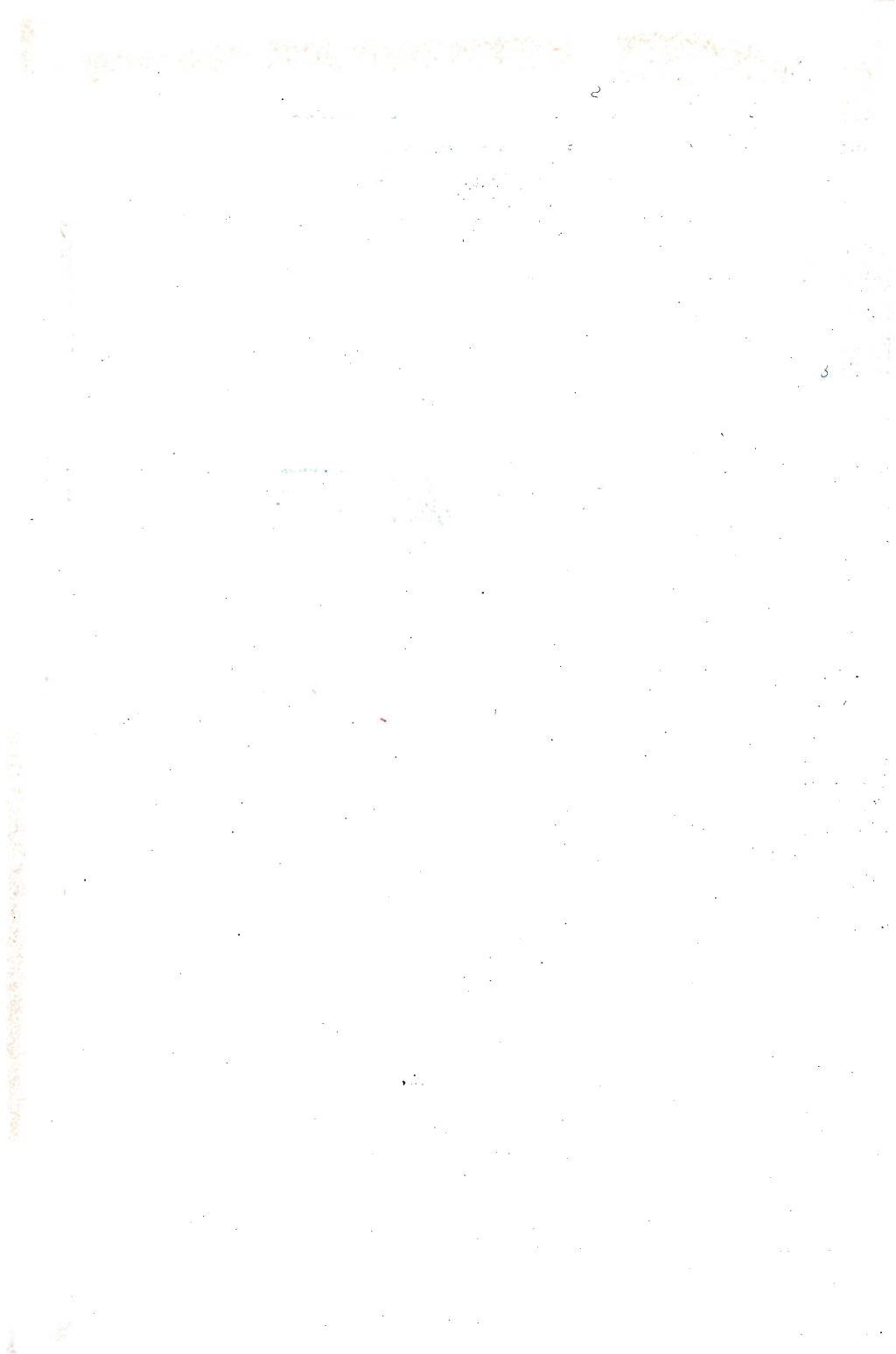

PHILIPS

PHILIPS

TYPE	USE	MATERIAL	POLARITY	MAXIMUM RATINGS						ELECTRICAL CHARACTERISTICS											OUTLINE TO.	NOTE	
				Pc 25°C (mW)	Tj (°C)	V _{av} (V)	V _{GB} (V)	I _c (mA)	I ₁₀₀ (μA)	V _{CE(V)}	h _{FE}		h _{FE}	h _{ie} (Ω)	h _{FE} (x10)	h _{oe} (μΩ)	f _T **f _α (MHz)	NF (dB)	C _{ob} (pF)	C _{oR0B} (ps)			
AC125	LF	G	P	500	90	32	12	100	10	10	100	2	125	1.7K	6.5	80	1.7	1KHZ				1	
AC126	LF	G	P	500	90	32	12	100	10	10	140	2	185	2.4K	8	100	2.3	1KHZ				1	
AC127	LF	G	N	340	100	32	16	500	15	10	100	20					2.5	1KHZ				1	AC127/01
AC128	LF	G	P	1W	100	32	16	1A	10	10	55	175	50				1.5	1A				1	AC128/01
AC132	LF	G	P	500	90	32	12	200	10	0.5	135	20					2	1KHZ				1	AC132/01
AC187	LF	G	N	1W	90	25	15	2A	15	25	100	500	1				5					1	AC187/01
AC188	LF	G	P	1W	90	25	15	2A	20	25	100	500	1				1.5					1	AC188/01
AF124	HF	G	P	60	75	32	15	10	90	6	150	1					75	100MHZ					72
AF125	HF	G	P	60	75	32	15	10	1.2	6	150	1					75	100MHZ					72
AF126	HF	G	P	60	75	32	15	10	1.2	6	150	1					75	100MHZ					72
AF127	HF	G	P	60	75	32	15	10	1.2	6	150	1					75	100MHZ					72
AF139	HF	G	P	60	90	20	15	10	0.5	20							550	800MHZ			3		72
AF239	HF	G	P	60	90	20	15	15	0.5	20							650	200MHZ					72
AF239S	HF	G	P	60	90	20	15	15									780	800MHZ					72
AF267	HF	G	P	60	90	20	15	10									780	800MHZ					P-10
ASY26	SW	G	P	150	85	30	15	200	7	30	45	10	50	750	5	65	8						5
ASY27	SW	G	P	150	85	25	15	200	7	25	80	10	90	1.4K	7.5	100	14						5
ASY28	SW	G	N	150	85	30	15	200	7	30	43	10	50	750	3.5	45	14						5
ASY29	SW	G	N	150	85	25	15	200	7	25	113	10	90	1.4K	5	70	20						5
ASY73	SW	G	N	140	75	30	15	400	3	5	20	200					4						5
ASY74	SW	G	N	140	75	30	15	400	3	5	35	200					6						5
ASY75	SW	G	N	140	75	30	15	400	3	5	50	200					10						5
ASY76	SW	G	P	500	85	40	32	1A	4.5	10	20	600					0.9	1KHZ	1.5				5
ASY77	SW	G	P	500	85	60	60	1A	4.5	10	20	600					0.9	1KHZ	1.5				5
ASY80	SW	G	P	500	85	40	40	1A	4.5	10	40	600					0.9	1KHZ	1.5				5
ASZ15	P	G	P	30W	90	100	60	8A	3mA	100	20	55	1A				0.2						3
ASZ16	P	G	P	30W	90	60	32	8A	3mA	60	45	130	1A				0.25						3
ASZ17	P	G	P	30W	90	60	32	8A	3mA	60	25	75	1A				0.22						3
ASZ18	P	G	P	30W	90	100	32	8A	3mA	100	30	110	1A				0.22						3
ASZ21	SW	G	P	120	85	20	15	50			30	10					300						18
AFY16	HF																						
AFY40	HF																						
AFY12	HF																						
BC107	LF	S	N	300	175	50	45	200	15	20				330	4.5K	2	30	300	1KHZ	1.4			18
BC108	LF	S	N	300	175	30	20	200	15	20				330	4.5K	2	30	300	1KHZ	1.4			18
BC109	LF	S	N	300	175	30	20	200	15	20				330	4.5K	2	30	300	1KHZ	1.4			18
BC146	LF	S	N	50	125	20	20	50			80	550		220	30K	25	20						P-1
BC147	LF	S	N	300	125		45	200	5	20				125				300	1KHZ	1.4			P-2
BC148	LF	S	N	300	125		20	200	5	20				125				300	1KHZ	1.4			P-2
BC149	LF	S	N	300	125		20	200	5	20				240				300	1KHZ	1.4			P-2
BC157	LF	S	P	300	125		45	200	1nA	20				75				150	1KHZ	1.2			P-2
BC158	LF	S	P	300	125		20	200	1nA	20				75				150	1KHZ	1.2			P-2
BC159	LF	S	P	300	125		20	200	1nA	20				125				150	1KHZ	1.2			P-2
BC177	LF	S	P	300	175		45	200	1nA	20				75				150	1KHZ	1.2			18
BC178	LF	S	P	300	175		25	200	1nA	20				75				150	1KHZ	1.2			18
BC179	LF	S	P	300	175		20	200	1nA	20				75				150	1KHZ	1.2			18
BC200	LF	S	P	50	125	20	20	50	100	20	50	400	0.2	75	12K	13	13	90	1KHZ	1.5			P-1
BC237	LF	S	N	300	125		45	200	5	20				125				300					P-3
BC238	LF	S	N	300	125		20	200	5	20				125				300					P-3
BC239	LF	S	N	300	125		20	200	5	20				240				300					P-3
BC307	LF	S	P	300	125		45	200	1nA	20				75				150	1KHZ	1.2			P-3
BC308	LF	S	P	300	125		25	200	1nA	20				75				150	1KHZ	1.2			P-3
BC309	LF	S	P	300	125		20	200	1nA	20				125				150	1KHZ	1.2			P-3
BC327	LF	S	P	625	150		45	1A	0.1	20	100	600	100					100					P-4
BC328	LF	S	P	625	150		25	1A	0.1	20	100	600	100					100					P-4

TYPE	TOSHIBA	NEC	HITACHI	MITSUBISHI	MATSUSHITA	FUJITSU	SONY	SANYO	NOTE
ACI 25		2SB 108							
ACI 26		2SB 108							
ACI 27							2SD 127		
ACI 28					2SB 481			2SB374	
ACI 32		2SB 108							
ACI 87		2SD 78	2SD 121H						
ACI 88		2SB 504							
AFI 24					2SA 100	2SA 273			
AFI 25					2SA 100	2SA 273			
AFI 26					2SA 100	2SA 273			
AFI 27					2SA 100	2SA 273			
AFI 39							2SA 456		
AF2 39							2SA 456		
AF2 39S							2SA 456		
AF2 67							2SA 456		
ASY 26		2SA 759	2SA 673A	2SA 696					
ASY 27		2SA 759	2SA 673A	2SA 696					
ASY 28		2SC 1216		2SC 619					
ASY 29		2SC 1216		2SC 619					
ASY 73	2SC 735			2SC 1210		2SC 1246			
ASY 74	2SC 735			2SC 1210		2SC 1246			
ASY 75	2SC 735			2SC 1210		2SC 1246			
ASY 76				2SB 458A					
ASY 77				2SB 458A					
ASY 80				2SB 458A					
ASZ 15	2SB 531						2SB 518		
ASZ 16	2SB 531						2SB 518		
ASZ 17	2SB 531						2SB 518		
ASZ 18	2SB 531						2SB 518		
ASZ 21	2SA 538	2SA 406							
AFY 16									
AFY 40									
AFY 12									
BCI 107	2SC 734			2SC 620		2SC 725	2SC 1364		
BCI 108	2SC 734			2SC 620		2SC 725	2SC 1364		
BCI 109	2SC 734			2SC 620		2SC 725	2SC 1364		
BCI 146	2SD 44		2SD 77		2SC 828				
BCI 147	2SC 734			2SC 620			2SC 1364		
BCI 148	2SC 734			2SC 620			2SC 1364		
BCI 149	2SC 734			2SC 620			2SC 1364		
BCI 157		2SA 718		2SA 696					
BCI 158		2SA 718		2SA 696					
BCI 159		2SA 718		2SA 696					
BCI 177		2SA 718		2SA 696					
BCI 178		2SA 718		2SA 696					
BCI 179		2SA 718		2SA 696					
BC200	2SA 495	2SA 542			2SA 564 A	2SA 556	2SA 677	2SA 609	
BC237	2SC 734			2SC 620		2SC 725	2SC 1364		
BC238	2SC 734			2SC 620		2SC 725	2SC 1364		
BC239	2SC 734			2SC 620		2SC 725	2SC 1364		
BC307		2SA 718		2SA 696					
BC308		2SA 718		2SA 696					
BC309		2SA 718		2SA 696					
BC327	2SA 513	2SA 606	2SA 537		2SA 546				
BC328	2SA 513	2SA 606	2SA 537		2SA 546				

PHILIPS

TYPE	USE	MATERIAL	POLARITY	MAXIMUM RATINGS						ELECTRICAL CHARACTERISTICS											OUTLINE TO:	NOTE						
				Pc 25°C (mW)	Tj (°C)	Vas (V)	Vas0 (V)	Ic (mA)	Ias0 (μA)	Vas(V) min.	max.	Ic(mA)	hfe	hie (Ω)	hre (x10 ³)	hoe (μS)	fT fT* fT0 (MHz)	NF (dB)	Cob (pF)	Coxf0b (ps)								
BC337	LF	S	N	625	150	45	1A	0.1	20	100	600	100						200						P-4				
BC338	LF	S	N		150	25	1A	0.1	20	100	600	100						200							P-4			
BC547	LF	S	N	30	150	45	200	5	20						125			300	10KHZ 1.4						P-4			
BC548	LF	S	N	300	150	20	200	5	20						125			300	10KHZ 1.4						P-4			
BC549	LF	S	N	300	150	20	200	5	20						240			300	10KHZ 1.4						P-4			
BC557	LF	S	P	300	150	45	200	1 nA	20						75			150	10KHZ 1.2						P-4			
BC558	LF	S	P	300	150	20	200	1 nA	20						75			150	10KHZ 1.2						P-4			
BC559	LF	S	P	300	150	20	200	1 nA	20						125			150	10KHZ 1.2						P-4			
BCW46	LF	S	N	200	150	80	60	200	10	80					125			300	1 KHZ 1.2						P-5			
BCW47	LF	S	N	200	150	50	45	200	10	50					125			300	1 KHZ 1.4						P-5			
BCW48	LF	S	N	200	150	30	20	200	10	30					125			300	1 KHZ 1.4						P-5			
BCW49	LF	S	N	200	150	30	20	200	10	30					240			300	1 KHZ 1.4						P-5			
BCW56	LF	S	P	200	150	80	60	200	10	80					125			150	1 KHZ 1.2						P-5			
BCW57	LF	S	P	200	150	50	45	200	10	50					125			150	1 KHZ 1.2						P-5			
BCW58	LF	S	P	200	150	30	20	200	10	30					125			150	1 KHZ 1.2						P-5			
BCW59	LF	S	P	200	150	30	20	200	10	30					125			150	1 KHZ 1.2						P-5			
BCY10	LF	S	P	415	150	32	32	250	20 nA	6	24	30	40					1.5	7						P-6			
BCY11	LF	S	P	415	150	60	60	250	20 nA	6	24	30	40					1.5	7						P-6			
BCY12	LF	S	P	415	150	32	32	250	20 nA	6	40	30	40					2	7						P-6			
BCY30	LF	S	P	250	150	64	50	100	1 nA	6	10	35	20					1.2							5			
BCY31	LF	S	P	250	150	64	50	100	1 nA	6	15	60	20					1.7							5			
BCY32	LF	S	P	250	150	64	50	100	1 nA	6	20	70	20					2.5							5			
BCY33	LF	S	P	250	150	32	25	100	1 nA	6	10	35	20					1.5							5			
BCY34	LF	S	P	250	150	32	25	100	1 nA	6	15	60	20					2.4							5			
BCY38	LF	S	P	410	150	32	24	500	1 nA	6	10	30	150					1.5							5			
BCY39	LF	S	P	410	150	64	60	500	1 nA	6	10	50	150					1.5							5			
BCY40	LF	S	P	410	150	32	24	500	1 nA	6	15	120	150					2.5							5			
BCY54	LF	S	P	410	150	50	50	500	1 nA	6	12	70	150					2							5			
BCY55																										DUAL		
BCY56	LF	S	N	300	175	45	45	100	0.1	20	100	450	2		250	3.5K	1.75	1.75	85	10KHZ 1.5						18		
BCY57	LF	S	N	300	175	25	20	100	0.1	20	200	800	2		500	7.5	3.5	35	100	10KHZ 1.5						18		
BCY58	LF	S	N	1W	200	32		200			120	630	2					280	10KHZ 2						18			
BCY59	LF	S	N	1W	200	45		200			120	630	2					280	10KHZ 2						18			
BCY70	LF	S	P	350	200	50	40	200	10 nA	40	50	10						250	10KHZ 2						18			
BCY71	LF	S	P	350	200	45	45	200	50 nA	40	100	10		100	2 K	20	10	200	10KHZ 2						18			
BCY72	LF	S	P	350	200	25	25	200	50 nA	20	50	10						200	10KHZ 2						18			
BCY87																										DUAL		
BCY88																										DUAL		
BCY89																										DUAL		
BCZ10	LF	S	P	250	150	25	25	50	1 nA	10					20											P-6		
BCZ11	LF	S	P	250	150	25	25	50	1 nA	10					35											P-6		
BCZ12	LF	S	P	250	150	60	60	50	10 nA	10					15											P-6		
BD115	P	S	N	6W		245	180	200	550	200	60		50					145								39		
BD131	P	S	N	11W	125	70	45	3 A	5	50	20	2	2 A					60								126		
BD132	P	S	P	11W	125	45	45	3 A	5	40	20		2 A					60								126		
BD133	P	S	N	11W	125	90	60	3 A	5	60	20		2 A					60								126		
BD135	P	S	N	8W	150	45	45	1 A	0.1		40	250	150					250								126		
BD136	P	S	P	8W	150	45	45	1 A	0.1	30	40	250	150					75								126		
BD137	P	S	N	8W	150	60	60	1 A	0.1	30	40	160	150					250								126		
BD138	P	S	P	8W	150	60	60	1 A	0.1	30	40	160	150					75								126		
BD139	P	S	N	8W	150	100	80	1 A	0.1	30	40	160	150					250								126		
BD140	P	S	P	8W	150	100	80	1 A	0.1	30	40	160	150					75								126		
BD181	P	S	N	117W	200	45	55	10A	2	45	20	70	3 A													3		
BD182	P	S	N	117W	200	60	70	15A	5	60	20	70	4 A													3		
BD183	P	S	N	117W	200	80	85	15A	5	80	20	70	3 A															

TYPE	TOSHIBA	NEC	HITACHI	MITSUBISHI	MATSUSHITA	FUJITSU	SONY	SANYO	NOTE
BC337	2SC 495				2SC 1407				
BC338	2SC 495				2SC 1407				
BC547	2SC 734			2SC 620		2SC 725	2SC 1364		
BC548	2SC 734			2SC 620		2SC 725	2SC 1364		
BC549	2SC 734			2SC 620		2SC 725	2SC 1364		
BC557	2SA 561	2SA 718				2SA 553			
BC558	2SA 561	2SA 718				2SA 553			
BC559	2SA 561	2SA 718				2SA 553			
BCW46	2SC 108A				2SC 563A	2SC 230			
BCW47	2SC 495	2SC 815		2SC 773	2SC 456			2SC423	
BCW48	2SC 356	2SC 1216		2SC 619		2SC 1372			
BCW49	2SC 356	2SC 1216		2SC 619		2SC 1372			
BCW56		2SA 539				2SA 555		2SA 532	
BCW57		2SA 539		2SA 696		2SA 555		2SA 532	
BCW58		2SA 539		2SA 696		2SA 555		2SA 532	
BCW59		2SA 539		2SA 696		2SA 555		2SA 532	
BCY10	2SB 461								
BCY11		2SB 108A							
BCY12	2SB 461								
BCY30				2SB 455					
BCY31				2SB 455					
BCY32				2SB 455					
BCY33				2SB 455					
BCY34				2SB 455					
BCY38		2SB 105							
BCY39		2SB 108A							
BCY40		2SB 105				2SB 17A			
BCY54		2SB 108A							
BCY55									
BCY56	2SC 1380		2SC 1345	2SC 1313					
BCY57						2SC 1264			
BCY58	2SC 486		2SC 708			2SC 971			
BCY59	2SC 486		2SC 708			2SC 971			
BCY70	2SA 561	2SA 718							
BCY71	2SA 561	2SA 718							
BCY72	2SA 561	2SA 718							
BCY87									
BCY88									
BCY89									
BCZ10					2SB 278				
11					2SB 278				
12					2SB 281				
BD115			2SC 1059						
BD131	2SC 1237	2SC 1306							
BD132				2SB 529				2SB 511	
BD133	2SC 1237	2SC 799							
BD135				2SC 1155					
BD136		2SB 243			2SB 493			2SB 474	
BD137				2SC 1155					
BD138		2SB 245				2SB 456			
BD139				2SC 1157					
BD140						2SB 456			
BD181	2SD 111	2SD 151				2SD 172			
BD182	2SD 111	2SD 151	2SD 341			2SD 250	2SD 340		
BD183	2SD 111	2SD 151	2SD 341			2SD 250	2SD 340		

PHILIPS

TYPE	USE	MATERIAL	POLARITY	MAXIMUM RATINGS						ELECTRICAL CHARACTERISTICS											OUTLINE TO-	NOTE							
				Pc 25°C (mW)	Tj (°C)	Vce (V)	Vce0 (V)	Ic (mA)	Ic0 (μA)	frc		Ic(mA)	hfe	hie (Ω)	hre (x10 ⁻⁴)	hoe (μS)	fT at I _b = I _{c0} (MHz)	NF (dB)	Cob (pF)	CotAb (ps)									
										Vce(V)	min.												max.						
BD201	P	S	N	60W	150	60	45	8A	1	40	30	3 A					3						P-7						
BD202	P	S	P	60W	150	60	45	8A	1	40	30	3 A					3							P-7					
BD203	P	S	N	60W	150	60	60	8A	1	40	30	2A					3							P-7					
BD204	P	S	P	60W	150	60	60	8A	1	40	30	2A					3							P-7					
BD226	P	S	N	12.5W	150	45	45	1.5A	0.1	30	25	1 A					125								126				
BD227	P	S	P	12.5W	150	45	45	1.5A	0.1	30	25	1 A					50								126				
BD228	P	S	N	12.5W	150	60	60	1.5A	0.1	30	25	1 A					125								126				
BD229	P	S	P	12.5W	150	60	60	1.5A	0.1	30	25	1 A					50								126				
BD230	P	S	N	12.5W	150	100	80	1.5A	0.1	30	25	1 A					125								126				
BD231	P	S	P	12.5W	150	100	80	1.5A	0.1	30	25	1 A					50								126				
BD232	P	S	N	7 W	125			300	250		20	150					20									126			
BD233	P	S	N	25W	150	45	45	2A	0.1	45	20	1A					3									126			
BD234	P	S	P	25W	150	45	45	2A	0.1	45	20	1A					3									126			
BD235	P	S	N	25W	150	60	60	2A	0.1	60	20	1A					3									126			
BD236	P	S	P	25W	150	60	60	2A	0.1	60	20	1A					3									126			
BD237	P	S	N	25W	150	100	80	2A	0.1	100	20	1A					3									126			
BD238	P	S	P	25W	150	100	80	2A	0.1	100	20	1A					3									126			
BD433	P	S	N	36W	150	22	22	4 A	0.1	22	50	2A					3									126			
BD434	P	S	P	36W	150	22	22	4 A	0.1	22	50	2A					3									126			
BD435	P	S	N	36W	150	32	32	4 A	0.1	32	50	2A					3									126			
BD436	P	S	P	36W	150	32	32	4 A	0.1	32	50	2A					3									126			
BD437	P	S	N	36W	150	45	45	4 A	0.1	45	40	2A					3									126			
BD438	P	S	P	36W	150	45	45	4 A	0.1	45	40	2A					3									126			
BDY20	P	S	N	115W	200	100	60	15A	3	100	20	70	4 A				1										3		
BDY38	P	S	N	115W	200	50	40	6A	3	50	30	2A					1										3		
BDY60	P	S	N	15W	175	120	60	5 A	10	100	45	500					100										3		
BDY61	P	S	N	15W	175	100	60	5 A	10	80	45	500					100										3		
BDY90	P	S	N	40W		120	100	10A		30	120	5 A					70										3		
BDY91	P	S	N	40W		100	80	10A		30	120	5 A					70										3		
BDY92	P	S	N	40W		80	60	10A		30	120	5 A					70										3		
BDY93	P	S	N	30W		750	350	3A		15	60	1A					8										3		
BDY94	P	S	N	30W		750	300	3A		25	80	1A					8										3		
BDY95	P	S	N	30W		600	250	3A		25	80	1A					8										3		
BDY96	P	S	N	40W		750	350	10A		15	60	2A					10										3		
BDY97	P	S	N	40W		750	300	10A		25	80	2A					10										3		
BDY98	P	S	N	40W		600	250	10A		25	80	2A					10										3		
BF115	HF	S	N	145	175	50	30	30		45	16.5	1					230	100MHz									72		
BF167	HF	S	N	130	175	40	30	25									350	35MHz										72	
BF173	HF	S	N	260	175	40	25	25									550											72	
BF177	HF	S	N	600	200	100	60	50		20	15						120											39	
BF178	HF	S	N	600	200	185	115	50		20	30						120											39	
BF179	HF	S	N	600	200	250	115	50		20	20						120						2.5					39	
BF180	HF	S	N	150	175	30	20	20									675	200MHz										72	
BF181	HF	S	N	150	175	30	20	20									600	900MHz										72	
BF182	HF	S	N	150	175	25	20	15									650	800MHz										72	
BF183	HF	S	N	150	175	25	20	15									800											72	
BF184	HF	S	N	145	175	30	20	30		115	1						300											72	
BF185	HF	S	N	145	175	30	20	30		67	1						220	100MHz										72	
BF194	HF	S	N	250	125	30	20	30		115	1						260	1MHz										P-2	
BF195	HF	S	N	250	125	30	20	30		67	1						200	100MHz										P-2	
BF196	HF	S	N	250	125	40	30	25									400	35MHz										P-2	
BF197	HF	S	N	250	125	40	25	25									550											P-2	
BF198	HF	S	N	500	150	40	30	25									400	35MHz										P-4	
BF199	HF	S	N	500	150	40	25	25									550											P-4	
BF200	HF	S	P	150	175	30	20	20									650	200MHz										72	

TYPE	TOSHIBA	NEC	HITACHI	mitsubishi	MATSUSHITA	FUJITSU	SONY	SANYO	NOTE
BD201	2SC 1080	2SD 217					2SD 338		
BD202	2SB 531						2SB 518		
BD203		2SD 217					2SD 338		
BD204	2SB 53						2SB 518		
BD226		2SC 1425							
BD227					2SB 126	2SB 445			
BD228	2SC 790		2SC 1061		2SC 1398				
BD229						2SB 446			
BD230					2SC 697		2SC 756-2		
BD231		2SB 241A							
BD232				2SC 1088					
BD233		2SD 288			2SD 317		2SD 291	2SD 330	
BD234		2SB 250A	2SB 471			2SB 151		2SB 216	
BD235	2SC 793	2SD 335			2SD 317		2SD 291	2SD 314	
BD236		2SB 250A	2SB 471			2SB 151		2SB 215	
BD237	2SC 793	2SD 335							
BD238		2SB 253A			2SB 128A	2SB 151		2SB 215	
BD433	2SC 789				2SD 226A			2SD 315	
BD434		2SB 248			2SB 128A	2SB 151	2SB 518	2SB 509	
BD435					2SD 226A			2SD 315	
BD436		2SB 248			2SB 128A	2SB 151	2SB 518	2SB 509	
BD437					2SD 226A			2SD 315	
BD438		2SB 248A			2SB 128A	2SB 151	2SB 518	2SB 509	
BDY20							2SD 340		
BDY38	2SD 111					2SD 172			
BDY60	2SC 793		2SC 665		2SC 901				
BDY61			2SC 664						
BDY90	2SC 558			2SC 769					
BDY91	2SC 558			2SC 769					
BDY92	2SC 558			2SC 769					
BDY93	2SC 1172	2SC 1358	2SC 1413	2SC 1309					
BDY94	2SC 1172	2SC 1358	2SC 1413	2SC 1309					
BDY95	2SC 1172	2SC 1358	2SC 1413	2SC 1309					
BDY96	2SC 1434								
BDY97	2SC 1434								
BDY98	2SC 1434								
BF115	2SC 372	2SC 1428	2SC 461						
BF167	2SC 372	2SC 1428	2SC 461						
BF173		2SC 1319				2SC 722			
BF177	2SC 995		2SC 154C				2SC 1127		
BF178	2SC 995		2SC 154C				2SC 1127		
BF179		2SC 1103				2SC 627			
BF180		2SC 1158							
BF181		2SC 1158							
BF182		2SC 1158							
BF183		2SC 1158							
BF184	2SC 392	2SC 253	2SC 717			2SC 1067			
BF185	2SC 392	2SC 253	2SC 717			2SC 1067			
BF194		2SC 1320				2SC 722			
BF195		2SC 1320				2SC 722			
BF196		2SC 1320				2SC 722			
BF197		2SC 1320				2SC 722			
BF198			2SC 151H				2SC 352		
BF199			2SC 151H				2SC 352		
BF200		2SC 1158							

TYPE	USE	MATERIAL	POLARITY	MAXIMUM RATINGS						ELECTRICAL CHARACTERISTICS													OUTLINE TO:	NOTE
				Pc 25°C (mW)	Tj (°C)	V _{ce} (V)	V _{ceo} (V)	I _c (mA)	I _{ceo} (μA)	V _{ce} (V)	I _{ce} min.	I _{ce} max.	I _{ce} (mA)	h _{FE}	h _{FE}	h _{ie}	h _{ie} (Ω)	h _{re} (×10 ⁻⁴)	h _{oe} (μS)	f _T *f ₁₈₀ (MHz)	NF (dB)	C _{ob} (pF)		
BF240	HF	S	N	250	125	40	40	25										380	200 KHz 3.5				P-4	
BF241	HF	S	N	250	125	40	40	25										350	200 KHz 3.5				P-4	
BF254	HF	S	N	300	125	30	20	30			15		1					260	100 MHz 4				P-4	
BF255	HF	S	N	300	125	30	20	30				67	1					200	100 MHz 4				P-4	
BF257	HF	S	N	5 W	175	160	160	200	1 nA	100	25		30					90					39	
BF258	HF	S	N	5 W	175	250	250	200	1 nA	200	25		30					90					39	
BF259	HF	S	N	5 W	175	300	300	200	1 nA	250	25		30					90					39	
BF324	HF	S	P	250	150	30	30	25	0.05	30								500	100 MHz 3				P-4	
BF336	HF	S	N	3 W	200	185	180	200				20		30				130				30	39	
BF337	HF	S	N	3 W	200	250	200	200				20		30				130					30	39
BF338	HF	S	N	3 W	200	300	225	200				20		30				130					30	39
BF450	HF	S	P	250	150	40	40	25										325	100 MHz 2				P-4	
BF451	HF	S	P	250	150	40	40	25										325	100 MHz 2				P-4	
BF457	HF	S	N	6 W	150	160	160	300	50 nA	100	26		30					90		4.5			126	
BF458	HF	S	N	6 W	150	250	250	300	50 nA	200	26		30					90		4.5			126	
BF459	HF	S	N	6 W	150	300	300	300	50 nA	250	26		30					90		4.5			126	
BF494	HF	S	N	300	150	30	20	30			115		10					260	100 MHz 4				P-4	
BF495	HF	S	N	300	150	30	20	30				67		10				200	100 MHz 4				P-4	
BFR63	HF	S	N	3.5 W	150	40	25	500	10	20	25		150					1000					P-8	
BFR64	HF	S	N	3.5 W	150	40	25	500	10	20	25		150					1200					P-8	
BFR65	HF	S	N	5 W	200	40	25	400	100	20	20		400					1000					P-8	
BFR90	HF	S	N	180	150	20	15	25	50 nA	10	25		14					5000	500 MHz 2, 4				P-9	
BFR91	HF	S	N	180	150	15	12	35	50 nA	5	25		30					5000	500 MHz 2, 4				P-9	
BFS92	HF	S	P	5 W	200	100	60	1A	50 nA	80	30		150	100	300	7000	60	70					39	
BFS93	HF	S	P	5 W	200	100	60	1A	50 nA	80	70		150	100	300	7000	60	70					39	
BFS94	HF	S	P	5 W	200	80	40	1A	50 nA	60	40		150	100	300	7000	60	70					39	
BFS95	HF	S	P	5 W	200	45	35	1A	50 nA	30	70		150	100	300	7000	60	70					39	
BFW16A	HF	S	N	1.5 W	200	40	25	300	20	20	25		150					1200	200 MHz 6				39	
BFW17A	HF	S	N	1.5 W	200	40	25	300	20	20	25		150					1100					39	
BFW30	HF	S	N	250	200	20	10	100	50 nA	10	25		50					1600	500 MHz 5				72	
BFW45	Defl	S	N	2.5 W	200	165	130	100	0.1	100	20		120	50				120					39	
BFW92	HF	S	N	190	150	25	15	50	50 nA	10	20		150	2				1600	500 MHz 5				P-9	
BFW93	HF	S	N	190	150	18	10	100	50 nA	10	25		50					1700	500 MHz 5				P-9	
BFX34	SW	S	N	5 W	200	120	60	2A			40		50	2A				100					39	
BFX44	HF	S	N	360	200	40	23	250	0.1	20	40		120	10				300					18	
BFX89	HF	S	N	200	200	30	15	50	10 nA	15	20		125	25				1200	800 MHz 7				72	
BFY50	HF	S	N	5 W	200	80	35	1A	2 nA	60	112		150	90	750	5	80	140					39	
BFY51	HF	S	N	5 W	200	60	30	1A	2 nA	40	123		150	100	750	5	80	160					39	
BFY52	HF	S	N	5 W	200	40	20	1A	2 nA	30	142		150	110	750	5	80	185					39	
BFY55	HF	S	N	800	200	80	35	1A	10 nA	60	40		120	150				60					39	
BFY90	HF	S	N	200	200	30	15	25			20		125	25				1400	800 MHz 5.5				72	
BSS27	SW	S	N	800	200	70	45	1A			30		150					400					39	
BSS28	SW	S	N	800	200	50	30	1A			40		150					400					39	
BSS29	SW	S	N	800	200	50	30	1A			25		150					400					39	
BSS40	SW	S	N	360	200	60	40	1A			25		500					200					18	
BSS41	SW	S	N	360	200	60	30	1A			25		500					200					18	
BSV15	SW	S	P	800	200			40	1A		40		250	100	20			50					39	
BSV16	SW	S	P	800	200			60	1A		40		250	100	20			50					39	
BSV17	SW	S	P	800	200			80	1A		40		160	100	20			50					39	
BSV64	SW	S	N	5 W	175	100	60	5 A	10	60	40		2A					100					39	
BSV68	SW	S	P	250	150	110	100	100	5	100	30		30					95					18	
BSV86	SW	S	N	220	150	75	30	400	0.1	60	100		300	150				100					P-5	
BSV87	SW	S	N	220	150	75	30	400	0.1	60	40		120	150				100					P-5	
BSV88	SW	S	N	220	150	60	25	400	0.1	30	35		150					100					P-5	
BSV96	SW	S	P	220	150	30	30	300	0.1	20	100		250	150				75					P-5	

TYPE	TOSHIBA	NEC	HITACHI	MITSUBISHI	MATSUSHITA	FUJITSU	SONY	SANYO	NOTE
BF240		2SC1320							
BF241		2SC1320							
BF254		2SC1320							
BF255		2SC1320							
BF257		2SC1456	2SC1304						
BF258		2SC1456	2SC1304						
BF259		2SC1456	2SC1304						
BF324	2SA494	2SA750					2SA678		
BF336			2SC685		2SC582				
BF337			2SC685		2SC582				
BF338			2SC685		2SC582				
BF450	2SA494						2SA678		
BF451	2SA494						2SA678		
BF457									
BF458									
BF459									
BF494		2SC1320				2SC722			
BF495		2SC1320				2SC722			
BFR63						2SC1484			
BFR64						2SC1484			
BFR65						2SC1484			
BFR90	2SC1193	2SC1268				2SC1421			
BFR91	2SC1193	2SC1268				2SC1421			
BFS92							2SA761		
BFS93							2SA761		
BFS94							2SA761		
BFS95							2SA761		
BFW16A		2SC1249				2SC1262			
BFW17A		2SC1249				2SC1262			
BFW30	2SC1164	2SC852				2SC1068			
BFW45					2SC1012				
BFW92		2SC1424							
BFW93		2SC1424							
BFX34					2SC697A		2SC756	2SC931	
BFX44	2SC498	2SC729		2SC306	2SC456	2SC202			
BFX89		2SC1424							
BFY50				2SC1224					
BFY51				2SC1224					
BFY52				2SC1224					
BFY55	2SC1381		2SC1212A						
BFY90		2SC1424							
BSS27	2SC1381		2SC1212A						
BSS28	2SC1381		2SC1212A						
BSS29	2SC1381		2SC1212A						
BSS40	2SC497				2SC1384				
BSS41	2SC497				2SC1384				
BSV15	2SA484						2SA762		
BSV16	2SA484						2SA762		
BSV17	2SA484						2SA762		
BSV64	2SC981								
BSV68		2SA675	2SA549A						
BSV86	2SC497			2SC309		2SC827			
BSV87	2SC497			2SC309		2SC827			
BSV88	2SC497			2SC309		2SC827			
BSV96		2SA642	2SA673			2SA555			

TYPE	TOSHIBA	NEC	HITACHI	MITSUBISHI	MATSUSHITA	FUJITSU	SONY	SANYO	NOTE
BSV97									
BSV98		2SA 642		2SA 695		2SA 555			
BSW41		2SC 890		2SC 1016					
BSW66				2SC 1224					
BSW67				2SC 1224					
BSW68				2SC 1224					
BSW69		2SC 1278	2SC 857K						
BSX12				2SC 1224					
BSX12A				2SC 1224					
BSX19	2SC 497			2SC 1211	2SC 1384				
BSX20	2SC 497			2SC 1211	2SC 1384				
BSX21						2SC 826			
BSX59	2SC 1381		2SC 1212A						
BSX60	2SC 1381		2SC 1212A						
BSX61	2SC 1381		2SC 1212A						
BSY38	2SC 400	2SC 943	2SC 1373			2SC 204			
BSY39	2SC 400	2SC 943	2SC 1373			2SC 204			
BU105		2SC 1358			2SD 299				
BU108		2SC 1358			2SD 299				
BU126					2SD 380				
BU132					2SD 246				
BU133	2SC 792	2SC 1106	2SC 935			2SC 825			
BU204					2SD 299				
BU205					2SD 299				
BU206					2SD 299				
BU207					2SD 299				
BU208					2SD 299				
BU209					2SD 299				
2N706A	2SC 503		2SC 1385			2SC 1150			
2N708	2SC 503		2SC 1385			2SC 1150			
2N743	2SC 735			2SC 619			2SC 1363		
2N744	2SC 735			2SC 619			2SC 1363		
2N753				2SC 1240					
2N914	2SC 503		2SC 1385			-2SC 1150			
2N918		2SC 1424							
2N929				2SC 1240		2SC 722			
2N930				2SC 1240		2SC 722			
2N1302	2SC 594	2SC 1216	2SC 321			2SC 565			
2N1303	2SA 562	2SA 642	2SA 673	2SA 695					
	2SC 594	2SC 1216	2SC 321			2SC 565			
2N1305	2SA 562	2SA 642	2SA 673	2SA 695					
2N1306	2SC 594	2SC 1216	2SC 321			2SC 565			
2N1307	2SA 562	2SA 642	2SA 673						
2N1308	2SC 594		2SC 321			2SC 565			
2N1309	2SA 562	2SA 642	2SA 673	2SA 695					
2N1613	2SC 1381		2SC 1212A						
2N1711	2SC 1381		2SC 1212A						
2N1893				2SC 1224					

PHILIPS

TYPE	USE	MATERIAL	POLARITY	MAXIMUM RATINGS						ELECTRICAL CHARACTERISTICS											OUTLINE TO:	NOTE
				Pc 25°C (mW)	Tj (°C)	Vce (V)	Vce (V)	Ic (mA)	Ibase (µA)	hfc			hfe	hie (Ω)	hre (×10 ³)	h _{oe} (µS)	f _T at I _{ce} * I _{be} (MHz)	NF (dB)	Cob (pF)	C _{ext} (ps)		
										Vce(V)	min.	max.										
2N2218	SW	S	N	800	175	60	30	800	10nA	50	35		10							39		
2N2218A	SW	S	N	800	175	75	40	800	10nA	60	35		10							39		
2N2219	SW	S	N	800	175	60	30	800	10nA	50	75		10							39		
2N2219A	SW	S	N	800	175	75	40	800	10nA	60	75		10							39		
2N2221	SW	S	N	500	175	60	30	800	10nA	50	35		10							18		
2N2221A	SW	S	N	500	175	75	40	800	10nA	60	35		10							18		
2N2222	SW	S	N	500	175	60	30	800	10nA	50	75		10							18		
2N2222A	SW	S	N	500	175	75	40	800	10nA	60	75		10							18		
2N2297	HF	S	N	800	200	80	35	1A	10nA	60	40	120	150							800	39	
2N2368	SW	S	N	360	200	40	15	500	0.4	20	20	60	10							400	18	
2N2369	SW	S	N	360	200	40	15	500	0.4	20	40	120	10							500	18	
2N2369A	SW	S	N	360	200	40	15	500	0.4	20	40	120	10							500	18	
2N2483	HF	S	N	360	200	60	60	50	10nA	45	175			80	1.5K	8	30	80	3		18	
2N2484	HF	S	N	360	200	60	60	50	10nA	45	250			150	3.5K	8	40	80	3		18	
2N2894	SW	S	P	360	200	12	12	200	80nA	6	40	150	30								18	
2N2894A	SW	S	P	360	200	12	12	200	50nA	10	40	120	30								18	
2N2904	SW	S	P	600	200	60	40	600	20nA	50	35		10							200	39	
2N2904A	SW	S	P	600	200	60	60	600	10nA	50	40		10							200	39	
2N2905	SW	S	P	600	200	60	40	600	20nA	50	75		10							200	39	
2N2905A	SW	S	P	600	200	60	60	600	10nA	50	100		10							200	39	
2N2906	SW	S	P	400	200	60	40	600	20nA	50	35		10							200	18	
2N2906A	SW	S	P	400	200	60	60	600	10nA	50	40		10							200	18	
2N2907	SW	S	P	400	200	60	40	600	20nA		75		10							200	18	
2N2907A	SW	S	P	400	200	60	60	600	10nA		100		10							200	18	
2N3055	P	S	N	115W	200	100	70	15A			20	70	4 A	15						0.8	3	
2N3303	SW	S	N	3 W	200	25	12	1A			30	120	300							450	39	
2N3426	SW	S	N	3 W	200	25	12	1A			30	120	300							450	39	
2N3442	P	S	N	117W	200	160	140	10A	50	140	20	70	3A								3	
2N3570	HF																					
2N3571	HF																					
2N3572	HF																					
2N3771	P	S	N	150W	200	50	40	30A	2 mA	50	15	60	15A							1.25	3	
2N3772	P	S	N	150W	200	100	60	20A	5 mA	100	15	60	10A							1.25	3	
2N4036	SW	S	P	5 W	200	90	65	1A	20nA	60	40	140	150							60	39	
2N4347	P	S	N	100W	200	140	120	5 A	50	140	20	70	4 A								3	

TYPE	TOSHIBA	NEC	HITACHI	MITSUBISHI	MATSUSHITA	FUJITSU	SONY	SANYO	NOTE
2N2218	2SC1381		2SC1212					2SC614	
2N2218A	2SC1381		2SC1212						
2N2219	2SC1381		2SC1212						
2N2219A	2SC1381		2SC1212						
2N2221	2SC1381		2SC1212						
2N2221A	2SC1381		2SC1212						
2N2222	2SC1381		2SC1212						
2N2222A	2SC1381		2SC1212						
2N2297	2SC1381		2SC1212						
2N2368	2SC503	2SC97A				2SC1150			
2N2369	2SC503	2SC97A				2SC1150			
2N2369A	2SC503	2SC97A				2SC1150			
2N2483				2SC1240					
2N2484				2SC1240					
2N2894	2SA497		2SA673A	2SA697					
2N2894A	2SA497		2SA673A	2SA697					
2N2904					2SA752				
2N2904A					2SA752				
2N2905					2SA752				
2N2905A					2SA752				
2N2906		2SA505			2SA731				
2N2906A		2SA505			2SA731				
2N2907		2SA505			2SA731				
2N2907A		2SA505			2SA731				
2N3055							2SD340		
2N3303				2SC1224				2SC614	
2N3426				2SC1224				2SC614	
2N3442			2SC1343				2SD262		
2N3570									
2N3571									
2N3572									
2N3771	2SD114					2SD250			
2N3772	2SD113	2SD132							
2N4036							2SA761		
2N4347	2SD118					2SD177			

Westinghouse

WESTING HOUSE

TYPE	USE	MATERIAL	POLARITY	MAXIMUM RATINGS					ELECTRICAL CHARACTERISTICS											OUTLINE TO-	NOTE					
				Pc 25°C (mW)	Tj (°C)	V ₀ (V)	V ₀ (V)	I _c (mA)	I ₀ (μA)	V ₀ (V)	f _{re} min.	f _{re} max.	I _c (mA)	I ₀ (μA)	h _{ie} (Ω)	h _{re} (x10 ⁴)	h _{oe} (μS)	f _T at I _c =I ₀ (MHz)	NF (dB)			C ₀ b (pF)	C ₀ b _b (ps)			
2N5038	SHP	S	N	140W	200	150	90	30A			20	100	12A	12									3			
2N5039	SHP	S	N	140W	200	120	75	30A			20	100	10A	12										3		
2N5929	SHP	S	N	175W	200	90	80	30A	10	20	100	10A					30		800					3		
2N5930	SHP	S	N	175W	200	130	120	30A	10	20	100	10A					30		800					3		
2N5931	SHP	S	N	175W	200	170	160	30A	10	20	100	10A					30		800					3		
2N5932	SHP	S	N	175W	200	70	60	30A	20/12	100/60	20A/30A						30		800					3		
2N5933	SHP	S	N	175W	200	110	100	30A	20/12	100/60	20A/30A						30		800					3		
2N5934	SHP	S	N	175W	200	150	140	30A	20/12	100/60	20A/30A						30		800					3		
1743-0610	SHP	S	N	175W	200	70	60	30A	8/20	40/100	30A/10A						30		800					3		
1743-1010	SHP	S	N	175W	200	110	100	30A	8/20	40/100	30A/10A						30		800					3		
1743-1410	SHP	S	N	175W	200	150	140	30A	8/20	40/100	30A/10A						30		800					3		
1743-1810	SHP	S	N	175W	200	190	180	30A	8/20	40/100	30A/10A						30		800					3		
1743-0820	SHP	S	N	175W	200	90	80	30A	20/12	100/60	20A/30A						30		800					3		
1743-1220	SHP	S	N	175W	200	130	120	30A	20/12	100/60	20A/30A						30		800					3		
1743-1620	SHP	S	N	175W	200	170	160	30A	20/12	100/60	20A/30A						30		800					3		
1743-1820	SHP	S	N	175W	200	190	180	30A	20/12	100/60	20A/30A						30		800					3		
1743-0630	SHP	S	N	175W	200	70	60	40A	20/10	100/50	30A/40A						30		800					3		
2N5935	SHP	S	N	175W	200	90	80	40A	20/10	100/50	30A/40A						30		800					3		
1743-1030	SHP	S	N	175W	200	110	100	40A	20/10	100/50	30A/40A						30		800					3		
2N5936	SHP	S	N	175W	200	130	120	40A	20/10	100/50	30A/40A						30		800					3		
1743-1430	SHP	S	N	175W	200	150	140	40A	20/10	100/50	30A/40A						30		800					3		
2N5937	SHP	S	N	175W	200	170	160	40A	20/10	100/50	30A/40A						30		800					3		
1743-1830	SHP	S	N	175W	200	190	180	40A	20/10	100/50	30A/40A						30		800					3		
1843	SHP	S	N	150W	200	375	350	30A	10m	350	15	5	5A					500						3		
2N1015	P	S	N	150W	150	30	30	7.5A			10	14	2A													
2N1015A	P	S	N	150W	150	60	60	7.5A			10	14	2A													
2N1015B	P	S	N	150W	150	100	100	7.5A			10	14	2A													
2N1015C	P	S	N	150W	150	150	150	7.5A			10	14	2A													
2N1015D	P	S	N	150W	150	200	200	7.5A			10	14	2A													
2N1015E	P	S	N	150W	150	250	250	7.5A			10	14	2A													
2N1015F	P	S	N	150W	150	300	300	7.5A			10	14	2A													
2N1016	P	S	N	150W	150	30	30	7.5A			10	18	5A													
2N1016A	P	S	N	150W	150	60	60	7.5A			10	18	5A													
2N1016B	P	S	N	150W	150	100	100	7.5A			10	18	5A													
2N1016C	P	S	N	150W	150	150	150	7.5A			10	18	5A													
2N1016D	P	S	N	150W	150	200	200	7.5A			10	18	5A													
2N1016E	P	S	N	150W	150	250	250	7.5A			10	18	5A													
2N1016F	P	S	N	150W	150	300	300	7.5A			10	18	5A													
2N3429	SW	S	N	150W	175		50	7.5A			10	35	5A				250 KHz		800							
2N3430	SW	S	N	150W	175		100	7.5A			10	35	5A				250 KHz		800							
2N3431	SW	S	N	150W	175		150	7.5A			10	35	5A				250 KHz		800							
2N3432	SW	S	N	150W	175		200	7.5A			10	35	5A				250 KHz		800							
2N3433	SW	S	N	150W	175		250	7.5A			10	35	5A				250 KHz		800							
2N2226	P	S	N	150W	150	50	50	10A			100	360	10A	7			500 KHz								U.H. GAI N	
2N2227	P	S	N	150W	150	100	100	10A			100	360	10A	7			500 KHz								U.H. GAI N	
2N2228	P	S	N	150W	150	150	150	10A			100	360	10A	7			500 KHz								U.H. GAI N	
2N2229	P	S	N	150W	150	200	200	10A			100	360	10A	7			500 KHz								U.H. GAI N	
2N2230	P	S	N	150W	150	50	50	10A			400	660	10A	7			500 KHz								U.H. GAI N	
2N2231	P	S	N	150W	150	50	50	10A			400	660	10A	7			500 KHz								U.H. GAI N	
2N2232	P	S	N	150W	150	100	100	10A			400	660	10A	7			500 KHz								U.H. GAI N	
2N2233	P	S	N	150W	150	150	150	10A			400	660	10A	7			500 KHz								U.H. GAI N	
2N3470	P	S	N	150W	150	50	50	10A			100	360	10A	7			500 KHz								U.H. GAI N	
2N3471	P	S	N	150W	150	100	100	10A			100	360	10A	7			500 KHz								U.H. GAI N	
2N3472	P	S	N	150W	150	150	150	10A			100	360	10A	7			500 KHz								U.H. GAI N	
2N3473	P	S	N	150W	150	200	200	10A			100	360	10A	7			500 KHz								U.H. GAI N	

TYPE	TOSHIBA	NEC	HITACHI	MITSUBISHI	MATSUSHITA	FUJITSU	SONY	E.T.C	NOTE
2N5038	2SD113Y								
2N5039	2SD113Y								
2N5929	2SD114Y								
2N5930						2SC1301			
2N5931						2SC1301			
2N5932	2SD114Y								
2N5933	2SD113Y								
2N5934						2SC1301			
1743-0610	2SD114Y								
1743-1010	2SD113Y								
1743-1410						2SC1301			
1743-1810						2SC1301			
1743-0820									
1743-1220									
1743-1620									
1743-1820									
1743-0630	2SC1435	2SD179							
2N5935	2SC1435	2SD179							
1743-1030	2SC1435	2SD179							
2N5936	2SC1435	2SD179							
1743-1430	2SC1435	2SD179							
2N5937	2SC1435	2SD179							
1743-1830	2SC1435	2SD179							
1843	2SC1435					2SC1302			
2N1015	2SD114					2SD196A			
2N1015A	2SD114	2SD132				2SD196A			
2N1015B	2SD113	2SD132				2SD196A			
2N1015C									
2N1015D									
2N1015E									
2N1015F									
2N1016		2SD132							
2N1016A		2SD132							
2N1016B		2SD132							
2N1016C						2SC1299			
2N1016D						2SC1299			
2N1016E						2SC1299			
2N1016F						2SC1299			
2N3429	2SD114-0								
2N3430	2SD113-0								
2N3431						2SC1301			
2N3432						2SC1301			
2N3433						2SC1301			
2N2226	2SD114Y								
2N2227	2SD113Y								
2N2228									
2N2229									
2N2230									
2N2231									
2N2232									
2N2233									
2N3470									
2N3471									
2N3472									
2N3473									

WESTING HOUSE

TYPE	USE	MATERIAL	POLARITY	MAXIMUM RATINGS					ELECTRICAL CHARACTERISTICS										OUTLINE TO.	NOTE				
				Pc	Tj	Va	Vao	lc	Iapp		hre			hfe	hie	hre	hoe	fT			NF	Cob	Cotbb	
				25°C (mW)	(°C)	(V)	(V)	(mA)	(μA)	Va(V)	min.	max.	lc(mA)	(Ω)	(x10)	(μΩ)	(dB)	(pF)			(ps)			
2N3474	P	S	N	150W	150	50	50	10A			400	660	10A				500							U.H.GAIN
2N3475	P	S	N	150W	150	100	100	10A			400	660	10A				500							U.H.GAIN
2N3476	P	S	N	150W	150	150	150	10A			400	660	10A				500							U.H.GAIN
2N3477	P	S	N	150W	150	200	200	10A			400	660	10A				500							U.H.GAIN
153-04	P	S	N	200W	175	65	40	7.5A		65	15		1.5A											
154-04	P	S	N	200W	175	65	40	7.5A		65	25		1.5A											
153-06	P	S	N	200W	175	85	60	7.5A			15		1.5A											
154-06	P	S	N	200W	175	85	60	7.5A			25		1.5A											
153-08	P	S	N	200W	175	105	80	7.5A			15		1.5A											
154-08	P	S	N	200W	175	105	80	7.5A			25		1.5A											
153-10	P	S	N	200W	175	125	100	7.5A			15		1.5A											
154-10	P	S	N	200W	175	125	100	7.5A			25		1.5A											
153-12	P	S	N	200W	175	145	120	7.5A			15		1.5A											
154-12	P	S	N	200W	175	145	120	7.5A			25		1.5A											
153-14	P	S	N	200W	175	165	140	7.5A			15		1.5A											
154-14	P	S	N	200W	175	165	140	7.5A			25		1.5A											
153-16	P	S	N	200W	175	185	160	7.5A			15		1.5A											
154-16	P	S	N	200W	175	185	160	7.5A			25		1.5A											
153-18	P	S	N	200W	175	205	180	7.5A			15		1.5A											
154-18	P	S	N	200W	175	205	180	7.5A			25		1.5A											
153-20	P	S	N	200W	175	225	200	7.5A			15		1.5A											
154-20	P	S	N	200W	175	225	200	7.5A			25		1.5A											
153-22	P	S	N	200W	175	245	220	7.5A			15		1.5A											
154-22	P	S	N	200W	175	245	220	7.5A			25		1.5A											
153-24	P	S	N	200W	175	265	240	7.5A			15		1.5A											
154-24	P	S	N	200W	175	265	240	7.5A			25		1.5A											
153-26	P	S	N	200W	175	285	260	7.5A			15		1.5A											
154-26	P	S	N	200W	175	285	260	7.5A			25		1.5A											
153-28	P	S	N	200W	175	305	280	7.5A			15		1.5A											
154-28	P	S	N	200W	175	305	280	7.5A			25		1.5A											
153-30	P	S	N	200W	175	325	300	7.5A			15		1.5A											
154-30	P	S	N	200W	175	325	300	7.5A			25		1.5A											
2N3055	P	S	N	115W	200	100	60	15A			20	70	4 A	15									3	
2N3442	P	S	N	117W	200	160	160	10A			20	70	3 A	12			25							3
2N3054	P	S	N	29W	200	90	90	4 A			25	100	0.5A	25										66
1714-0402	S	S	N	100W	200	50	40	10A			20		2 A				40		250					66
1714-0405	S	S	N	100W	200	50	40	10A			20		5 A				40		250					66
1714-0602	S	S	N	100W	200	70	60	10A			20		2 A				40		250					66
1714-0605	S	S	N	100W	200	70	60	10A			20		5 A				40		250					66
1714-0802	S	S	N	100W	200	90	80	10A			20		2 A				40		250					66
1714-0805	S	S	N	100W	200	90	80	10A			20		5 A				40		250					66
1714-1002	S	S	N	100W	200	110	100	10A			20		2 A				40		250					66
1714-1005	S	S	N	100W	200	110	100	10A			20		5 A				40		250					66
1714-1202	S	S	N	100W	200	130	120	10A			20		2 A				40		250					66
1714-1205	S	S	N	100W	200	130	120	10A			20		5 A				40		250					66
1714-1402	S	S	N	100W	200	150	140	10A			20		2 A				40		250					66
1714-1405	S	S	N	100W	200	150	140	10A			20		5 A				40		250					66
1714-1602	S	S	N	100W	200	170	160	10A			20		2 A				40		250					66
1714-1605	S	S	N	100W	200	170	160	10A			20		5 A				40		250					66
1714-1802	S	S	N	100W	200	190	180	10A			20		2 A				40		250					66
1714-1805	S	S	N	100W	200	190	180	10A			20		5 A				40		250					66
1723-0405	S	S	N	100W	200	50	40	20A			20		5 A				30		800					3
1723-0410	S	S	N	100W	200	50	40	20A			20		10A				30		800					3
1723-0605	S	S	N	100W	200	70	60	20A			20		5 A				30		800					3
1723-0610	S	S	N	100W	200	70	60	20A			20		10A				30		800					3

TYPE	TOSHIBA	NEC	HITACHI	mitsubishi	MATSUSHITA	FUJITSU	SONY	SANYO	NOTE
2N3474									
2N3475									
2N3476									
2N3477									
I53-04	2SD114Y								
I54-04	2SD114Y								
I53-06	2SD113Y								
I54-06	2SD113Y								
I53-08									
I54-08									
I53-10									
I54-10									
I53-12									
I54-12									
I53-14									
I54-14									
I53-16									
I54-16									
I53-18									
I54-18									
I53-20									
I54-20									
I53-22									
I54-22									
I53-24									
I54-24									
I53-26									
I54-26									
I53-28									
I54-28									
I53-30									
I54-30									
2N3055	2SD113Y								
2N3442									
2N3054	2SD131		2SD125			2SD175			
I714-0402	2SC1080	2SD151				2SD176			
I714-0405		2SD151				2SD176			
I714-0602	2SC1080					2SD176			
I714-0605						2SD176			
I714-0802	2SC1080					2SD176			
I714-0805						2SD176			
I714-1002	2SC1080					2SD177			
I714-1005						2SD177			
I714-1202	2SC1079					2SD197A			
I714-1205						2SD197A			
I714-1402	2SC1079					2SC1229			
I714-1405						2SC1229			
I714-1602						2SC1229			
I714-1605						2SC1229			
I714-1802						2SC1229			
I714-1805						2SC1229			
I723-0405	2SD114Y					2SD231			
I723-0410	2SD114Y					2SD231			
I723-0605	2SD114Y					2SD232			
I723-0610	2SD114Y					2SD232			

WESTING HOUSE

TYPE	USE	MATERIAL	POLARITY	MAXIMUM RATINGS					ELECTRICAL CHARACTERISTICS													OUTLINE TO.	NOTE			
				Pc 25°C (mW)	Tj (°C)	Vce (V)	Vce (V)	Ic (mA)	Ic (μA)	Vce(V)	min.	hfe max:	Ic(mA)	hfe	hie (Ω)	hfe (x10 ⁴)	hoe (μΩ)	fT fα fβ (MHz)	NF (dB)	Cob (pF)	Coi (ps)					
1723-0805	S.A	S	N	100W	200	90	80	20A			20				5A						30 10MHz		800		3	
1723-0810	S.A	S	N	100W	200	90	80	20A			20				10A						30 10MHz		800		3	
1723-1005	S.A	S	N	100W	200	110	100	20A			20				5A						30 10MHz		800		3	
1723-1010	S.A	S	N	100W	200	110	100	20A			20				10A						30 10MHz		800		3	
1723-1205	S.A	S	N	100W	200	130	120	20A			20				5A						30 10MHz		800		3	
1723-1210	S.A	S	N	100W	200	130	120	20A			20				10A						30 10MHz		800		3	
1723-1405	S.A	S	N	100W	200	150	140	20A			20				5A						30 10MHz		800		3	
1723-1410	S.A	S	N	100W	200	150	140	20A			20				10A						30 10MHz		800		3	
1723-1605	S.A	S	N	100W	200	170	160	20A			20				5A						30 10MHz		800		3	
1723-1610	S.A	S	N	100W	200	170	160	20A			20				10A						30 10MHz		800		3	
1723-1805	S.A	S	N	100W	200	190	180	20A			20				5A						30 10MHz		800		3	
1723-1810	S.A	S	N	100W	200	190	180	20A			20				10A						30 10MHz		800		3	
2N3711	S.A	S	N	150W	200	50	40	30A	2 m	50	15	60			15A						1.5		500		3	
1561-0615	S.A	S	N	150W	200	60	60	30A	2 m	50	15	60			15A						1.5		500		3	
1561-0815	S.A	S	N	150W	200	80	80	30A	2 m	50	15	60			15A						1.5		500		3	
1561-1015	S.A	S	N	150W	200	100	100	30A	2 m	50	15	60			15A						1.5		500		3	
1561-1215	S.A	S	N	150W	200	120	120	30A	2 m	50	15	60			15A						1.5		500		3	
1561-1415	S.A	S	N	150W	200	140	140	30A	2 m	50	15	60			15A						1.5		500		3	
1561-1615	S.A	S	N	150W	200	160	160	30A	2 m	50	15	60			15A						1.5		500		3	
2N3722	S.A	S	N	150W	200	100	60	20A	5 m	60	15	60			15A						1.5		600		3	
1561-0410	S.A	S	N	150W	200	50	40	20A	5 m	40	15	60			15A						1.5		600		3	
1561-0610	S.A	S	N	150W	200	70	60	20A	5 m	60	15	60			15A						1.5		600		3	
1561-0810	S.A	S	N	150W	200	90	80	20A	5 m	80	15	60			15A						1.5		600		3	
1561-1010	S.A	S	N	150W	200	110	100	20A	5 m	100	15	60			15A						1.5		600		3	
1561-1210	S.A	S	N	150W	200	130	120	20A	5 m	120	15	60			15A						1.5		600		3	
1561-1410	S.A	S	N	150W	200	150	140	20A	5 m	140	15	60			15A						1.5		600		3	
1561-1610	S.A	S	N	150W	200	170	160	20A	5 m	160	15	60			15A						1.5		600		3	
2N3773	S.A	S	N	150W	200	160	140	16A	5 m	140	15	60			8A						1.5		600		3	
1561-0408	S.A	S	N	150W	200	50	40	20A	5 m	40	15	60			8A						1.5		600		3	
1561-0608	S.A	S	N	150W	200	70	60	20A	5 m	60	15	60			8A						1.5		600		3	
1561-0808	S.A	S	N	150W	200	90	80	20A	5 m	80	15	60			8A						1.5		600		3	
1561-1008	S.A	S	N	150W	200	110	100	20A	5 m	100	15	60			8A						1.5		600		3	
1561-1208	S.A	S	N	150W	200	130	120	20A	5 m	120	15	60			8A						1.5		600		3	
1561-1608	S.A	S	N	150W	200	170	160	20A	5 m	160	15	60			8A						1.5		600		3	

AEG-TELEFUNKEN

AEG-TELEFUNKEN

TYPE	USE	MATERIAL	POLARITY	MAXIMUM RATINGS							ELECTRICAL CHARACTERISTICS														OUTLINE TO	NOTE
				Pc 25°C (mW)	Tj (°C)	V ₀ (V)	V ₀₀ (V)	Ic (mA)	I ₀₀		h _{FE}		hfe	h _{ie} (Ω)	h _{re} (×10 ⁻⁴)	h _{oe} (μS)	f _T *f _{0E} *f ₁₀₀ (MHz)	NF (dB)	Cob (pF)	C ₀₁₀ (ps)						
									(μA)	V ₀₀ (V)	min.	max.									ic(mA)					
AC116	AF	G	P	145	90	30	18	200	4.5	6	55	140	4						21	DN 18B3						
AC117	AF	G	P	260	90	32	18	1 A	6	6	40	110	300				10			DN 18B3						
AC122	AF	G	P	130	90	30	18	200	8	6	40	300	2				15	21		DN 18B3						
AC122-30	AF	G	P	130	90	45	32	200	8	6	40	300	2				15	21		DN 18B3						
AC123	AF	G	P	145	90	45	32	200	8	6	55	140	4						2	DN 18B3						
AC124	AF	G	P	260	90	45	32	1 A	18	6	40	170	300				11			DN 18B3						
AC131	AF	G	P	215	90	30	18	1 A	18	6	40	120	300							DN 18B3						
AC131-30	AF	G	P	215	90	45	32	1 A	18	6	40	120	300							DN 18B3						
AC150	AF	G	P	60	75	30	18	50	8	6	180	300	2	100	2 K	5.5	52		5	21	DN 18B3					
AC170	AF	G	P	90	90	32	32	200	10	10	50	125	2	80	2.5K	5.5	65	1.2	5	21	DN 18B3					
AC171	AF	G	P	90	90	32	32	200	10	10	65	180	2	130	4 K	6	83	1.7	5	21	DN 18B3					
AC175	AF	G	N	260	90	25	18	1 A	13	15	60	165	50								DN 18B3					
AC178	AF	G	P	180	90	20	15	700	6	6	60	185	50								DN 18B3					
AC179	AF	G	N	180	90	20	15	700	10	6	60	185	50								DN 18B3					
AC186	AF	G	N	215	90	30	18	700	13	15	60	400	50								DN 18B3					
AC187K	AF	G	N	1 W	90	25	15	1 A	7	10	100	500	300				5		100		DN 18B3					
AC188K	AF	G	P	1 W	90	25	15	1 A	5	10	100	500	300				1.5		100		DN 18B3					
AD149	P	G	P	27.5W	100	50	30	3.5A	1m	32	30	100	1 A				0.3		220		3					
AD150	P	G	P	27.5W	100	32	30	3.5A	1m	32	50	100	1 A				0.45				3					
AD152	P	G	P	6 W	90	45	23	1 A	20	6	35	160	500								SOT 9					
AD155	P	G	P	6 W	90	25	15	1 A	20	6	35	115	500								SOT 9					
AD161	P	G	N	4 W	90	32	20	1 A	50	20	80	320	500								SOT 9					
AD162	P	G	P	6 W	90	32	20	1 A	40	20	80	320	500								SOT 9					
AD164	P	G	P	6 W	90	25	20	1 A	20	6	60	185	500								SOT 9					
AD165	P	G	N	5.3W	90	25	20	1 A	15	6	60	185	500								SOT 9					
AF106	HF	G	P	60	90	25	18	10	0.5	12	25	50	1	30			200			6	72					
AF109R	HF	G	P	60	90	20	15	10	0.5	20	55		2				270				72					
AF121	HF	G	P	67	75	25	25	10	1.2	10																
AF134	HF	G	P	60	75	25	18		2.5	6	110		1	110			55			25						
AF135	HF	G	P	60	75	25	18		3	6	100		1				50			25	DN 18					
AF136	HF	G	P	60	75	25			3	6	80		1				40			25	DN 18					
AF137	HF	G	P	60	75	25			3	6	60		1				35			25	DN 18					
AF138	HF	G	P	60	75	25			1.5	6	60	100	1				40			25	DN 18					
AF139	HF	G	P	60	90	20	15	10	0.5	20	10	55	2				550			3	72					
AF239	HF	G	P	60	90		15	10	0.5	20	10	33	2				650				72					
AF239S	HF	G	P	60	90		15	10			10	50	2				780				72					
AF256	HF	G	P	90	90		25	18	10	0.5	12	10	28	1			330			12	SOT 25					
AF279	HF	G	P	60	90		15	10			10	50	2				780				50					
AF280	HF	G	P	60	90		15	10			10	25	2				550				50					

TYPE	TOSHIBA	NEC	HITACHI	mitsubishi	MATSUSHITA	FUJITSU	SONY	SANYO	NOTE
AC116	2SB63	2SB105		2SB135			2SB52		
AC117				2SB356					
AC122				2SB135					
AC122-30		2SB108A							
AC123		2SB108A							
AC124				2SB458A					
AC131	2SB415			2SB458A					
AC131-30				2SB458A					
AC150	2SB439			2SB134					
AC170	2SB461			2SB453	2SB371				
AC171				2SB135					
AC175	2SC513			2SC775		2SC224			
AC178	2SB415			2SB494					
AC179	2SC992								
AC186	2SC992								
AC187K	2SC513		2SC315						
AC188K				2SB458				2SB373	
AD149	2SB424	2SB248A	2SB361					2SB509	
AD150	2SB426	2SB248	2SB361					2SB509	
AD152	2SB462			2SB524					
AD155	2SB463				2SB493			2SB492	
AD161	2SC525	2SC637				2SC541			
AD162	2SB463				2SB481				
AD164	2SB463				2SB481				
AD165		2SC637		2SC699		2SC541			
AF106	2SA495		2SA373A		2SA447				
AF109R	2SA518		2SA373A		2SA447				
AF121	2SA500				2SA447				
AF134	2SA594					2SA524			
AF135	2SA594					2SA524			
AF136	2SA495								
AF137	2SA495								
AF138	2SA495								
AF139		2SA404			2SA310	2SA524			
AF239					2SA310	2SA524			
AF239S					2SA310	2SA524			
AF256					2SA310				
AF279					2SA310				
AF280					2SA310				

AEG-TELEFUNKEN

TYPE	USE	MATERIAL	POLARITY	MAXIMUM RATINGS				ELECTRICAL CHARACTERISTICS											OUTLINE TO-	NOTE				
				Pc 25°C (mW)	Ti (°C)	V _{as} (V)	V _{abd} (V)	I _c (mA)	I _{abd}		h _{FE}		h _{FE}	h _{ie} (Ω)	h _{re} (x10 ⁻⁴)	h _{oe} (μS)	f _T *f _{oe} **f _{ao} (MHz)	NF (dB)			C _{ob} (pF)	C _o *t _{ob} (ps)		
									μA	V _{as} (V)	min.	max.											ic(mA)	
BC107A	AF	S	N	300	175	50	45	100	15	20	125	260	2					300	10	2.5		18		
BC107B	AF	S	N	300	175	50	45	100	15	20	240	500	2					300	10	2.5		18		
BC108A	AF	S	N	300	175	30	20	100	15	20	125	260	2					300	10	2.5		18		
BC108B	AF	S	N	300	175	30	20	100	15	20	240	500	2					300	10	2.5		18		
BC108C	AF	S	N	300	175	30	20	100	15	20	450	900	2					300	10	2.5		18		
BC109B	AF	S	N	300	175	30	20	100	15	20	240	500	2					300	10	2.5		18		
BC109C	AF	S	N	300	175	30	20	100	15	20	450	900	2					300	10	2.5		18		
BC110	AF	S	N	300	175	80	80	50	100n	80	30	90	2					100		5		18		
BC129A	AF	S	N	135	175	50	45	100	15	20		180	2	125	2.7	1.5	18	300	3	4.5		18		
BC129B	AF	S	N	135	175	50	45	100	15	20		290	2	240	4.5	2	30	300	3	4.5		18		
BC130A	AF	S	N	135	175	30	20	100	15	20		180	2	125	2.7	1.5	18	300	3	4.5		18		
BC130B	AF	S	N	135	175	30	20	100	15	20		290	2	240	4.5	2	30	300	3	4.5		18		
BC130C	AF	S	N	135	175	30	20	100	15	20		520	2	450	8.7	3	60	300	3	4.5		18		
BC131B	AF	S	N	135	175	30	20	100	15	20		290	2	240	4.5	2	30	300	4	4.5		18		
BC131C	AF	S	N	135	175	30	20	100	15	20		520	2	450	8.7	3	60	300	4	4.5		18		
BC140	AF	S	N	650	175			40	1A			40	250	100				50				39		
BC141	AF	S	N	650	175			60	1A			40	250	100				50	10			39		
BC147A	AF	S	N	300	175	50	45	100	5	20	125	260	2					300	10	2.5		SOT 25		
BC147B	AF	S	N	300	175	50	45	100	5	20	240	500	2					300		2.5		SOT 25		
BC148A	AF	S	N	300	175	30	20	100	5	20	125	260	2					300				SOT 25		
BC148B	AF	S	N	300	175	30	20	100	5	20	240	500	2					300				SOT 25		
BC148C	AF	S	N	300	175	30	20	100	5	20	450	900	2					300				SOT 25		
BC149B	AF	S	N	300	175	30	20	100	5	20	240	500	2					300				SOT 25		
BC149C	AF	S	N	300	175	30	20	100	5	20	450	900	2					300				SOT 25		
BC155	AF	S	N	105	125	5	5	50	100n	5	85	900	0.5					50				TOM 13		
BC156	AF	S	N	50	125	5	5	50	100n	5	85	900	0.5					50				TOM 23		
BC160	AF	S	P	650	175			40	1A			40	250	100				50				39		
BC161	AF	S	P	650	175			60	1A			40	250	100				50				39		
BC167	AF	S	N	300	150	50	45	100	5	20	180	290	2					300				92		
BC168	AF	S	N	300	150	30	20	100	5	20	180	520	2					300				92		
BC169	AF	S	N	300	150	30	20	100	5	20	290	520	2					300				92		
BC177V1	AF	S	P	300	175	50	45	100	10	20	75	150	2	75	1.4	2.5	20	130	10	4.5		18		
BC177A	AF	S	P	300	175	50	45	100	10	20	125	260	2	125	2.7	3	25	130	10	4.5		18		
BC177B	AF	S	P	300	175	50	45	100	10	20	240	500	2	240	4.5	3.5	35	130	10	4.5		18		
BC178V1	AF	S	P	300	175	30	25	100	10	20	75	150	2	75	1.4	2.5	20	130	10	4.5		18		
BC178A	AF	S	P	300	175	30	25	100	10	20	125	260	2	125	2.7	3	25	130	10	4.5		18		
BC178B	AF	S	P	300	175	30	25	100	10	20	240	500	2	240	4.5	3.5	35	130	10	4.5		18		
BC178C	AF	S	P	300	175	30	25	100	10	20	450	900	2	450	8.7	4	45	130	10	4.5		18		
BC179A	AF	S	P	300	175	25	20	100	10	20	125	260	2	125	1.4	3	25	130	10	4.5		18		
BC179B	AF	S	P	300	175	25	20	100	10	20	240	500	2	240	2.7	3.5	35	130	10	4.5		18		
BC179C	AF	S	P	300	175	25	20	100	10	20	450	900	2	450	4.5	4	45	130	10	4.5		18		
BC182A	AF	S	N	300	150	60	50	200	15n	50	125	260	2	260				150	10	5		92		
BC182B	AF	S	N	300	150	60	50	200	15n	50	240	500	2	500				150	10	5		92		
BC194	-	S	N	105	125	40	25	800	100n	30	40	250	10					100		8		TOM 13		
BC196V1	AF	S	P	50	125	30	25	100	50n	20	140	2	75					150	10	4		TOM 23		
BC196A	AF	S	P	50	125	30	25	100	50n	20	180	2	125					200	10	4		TOM 23		
BC196B	AF	S	P	50	125	30	25	100	50n	20	290	2	240					250	10	4		TOM 23		
BC197	AF	S	N	135	175	50	45	100	5	20	180	2	250		2.7	1.5	30	300	10			TOM 23		
BC198A	AF	S	N	135	175	30	20	100	5	20	180	2	220		2.7	1.5	18	300	10	4.5		TOM 23		
BC198B	AF	S	N	135	175	30	20	100	5	20	290	2	330		4.5	2	30	300	10	4.5		TOM 23		
BC198C	AF	S	N	135	175	30	20	100	5	20	520	2	600		8.7	3	60	300	10	4.5		TOM 23		
BC199	AF	S	N	135	175	30	20	100	5	20	290	520	2	330		4.5	2	30	300	10	4.5		TOM 23	
BC212	AF	S	P	300	150	60	50	200	15n	30	60	300	2	300				200	10	5		92		
BC237A	AF	S	N	300	150	50	45	100	5	20	125	260	2	220		2.7	1.5	18	300	10	4.5		92	
BC237B	AF	S	N	300	150	50	45	100	5	20	240	500	2	330		4.5	2	30	300	10	4.5		92	

TYPE	TOSHIBA	NEC	HITACHI	mitsubishi	MATSUSHITA	FUJITSU	E. T. C	SANYO	NOTE
BC107A	2SC980		2SC152	2SC302	2SC478				
BC107B	2SC980		2SC152	2SC302	2SC478				
BC108A	2SC733			2SC301		2SC565		2SC427	
BC108B	2SC733			2SC301		2SC565		2SC427	
BC108C	2SC733			2SC301		2SC565		2SC427	
BC109B				2SC301				2SC427	
BC109C				2SC301				2SC427	
BC110						2SC205			
BC129A	2SC734			2SC714					
BC129B	2SC734			2SC714					
BC130A	2SC1000	2SC651		2SC712		2SC965			
BC130B	2SC1000	2SC651		2SC712		2SC965			
BC130C	2SC1000	2SC651		2SC712		2SC965			
BC131B	2SC1000	2SC651		2SC712		2SC965			
BC131C	2SC1000	2SC651		2SC712		2SC965			
BC140	2SC486		2SC708						
BC141	2SC486		2SC708A						
BC147A	2SC1000			2SC714					
BC147B	2SC1000			2SC714					
BC148A	2SC1000	2SC651		2SC712		2SC965			
BC148B	2SC1000	2SC651		2SC712		2SC965			
BC148C	2SC1000	2SC651		2SC712		2SC965			
BC149B	2SC1000	2SC651		2SC712		2SC965			
BC149C	2SC1000	2SC651		2SC712		2SC965	(J)		
BC155							2SC1288		
BC156							2SC1288		
BC160		2SA571		2SB458A					
BC161		2SA571		2SB458B					
BC167			2SC317						
BC168				2SC619		2SC238			
BC169				2SC619		2SC238			
BC177V1		2SA710		2SA697					
BC177A		2SA710		2SA697					
BC177B		2SA710		2SA697					
BC178V1	2SA402	2SA710		2SA696					
BC178A	2SA402	2SA710		2SA696					
BC178B	2SA402	2SA710		2SA696					
BC178C	2SA402	2SA710		2SA696					
BC179A	2SA402	2SA710	2SA373A	2SA695					
BC179B	2SA402	2SA710	2SA373A	2SA695					
BC179C	2SA402	2SA710	2SA373A	2SA695			(JRC)		
BC182A		2SC853	2SC479	2SC307			2SC952		
BC182B		2SC853	2SC479	2SC307			2SC952		
BC194	2SC468			2SC303					
BC196V1				2SA375	2SA564A			2SA608	
BC196A				2SA375	2SA564A			2SA608	
BC196B				2SA375	2SA564A			2SA608	
BC197	2SC980			2SC302					
BC198A	2SC1000			2SC302					
BC198B	2SC1000			2SC302					
BC198C	2SC1000			2SC302					
BC199	2SC1000			2SC302					
BC212		2SA544		2SA697					
BC237A	2SC734			2SC714					
BC237B	2SC734			2SC714					

AEG-TELEFUNKEN

TYPE	USE	MATERIAL	POLARITY	MAXIMUM RATINGS					ELECTRICAL CHARACTERISTICS											OUTLINE TO.	NOTE		
				Pc 25°C (mW)	Tj (°C)	V _o (V)	V _o p (V)	I _c (mA)	I _o (μA)		h _{FE}		h _{FE}	h _{ie} (Ω)	h _{re} (x10)	h _{oe} (μΩ)	f _T (MHz)	NF (dB)	C _{ob} (pF)			C _o r _{rb} (ps)	
BC238	AF	S	N	300	150	30	20	100	5	20	180	520	2	330	4.5	2	30	300	4	2.5		92	
BC239	AF	S	N	300	150	30	20	100	5	20	290	520	2	330	4.5	2	30	300	4	2.5		92	
BC307	AF	S	P	300	150	50	45	100	10	20	140	290	2	330	4.5	3	35	130	4	2.5		92	
BC308	AF	S	P	300	150	30	25	100	10	20	140	520	2	330	4.5	3	35	130	4	2.5		92	
BC309	AF	S	P	300	150	25	20	100	10	20	180	520	2	330	4.5	3	35	130	4	2.5		92	
BC327	AF	S	P	500	150			45	500			63	630	100			100		12			92	
BC328	AF	S	P	500	150			25	500			63	630	100			100		12			92	
BC337	AF	S	N	500	150			45	500			63	630	100			100		12			92	
BC338	AF	S	N	500	150			25	500			63	630	100			100		12			92	
BC413	AF	S	N	300	150	45	30	100	15n	30	180	800	2	600	8.7K	3	60	250	3	2.5		92	lownoise
BC414	AF	S	N	300	150	50	45	100	15n	30	180	800	2	600	8.7K	3	60	250	3	2.5		92	
BC415	AF	S	P	300	150	45	35	100	15n	30	120	800	2	330	8 K	3.5	70	200	2	4.5		92	
BD416	AF	S	P	300	150	50	45	100	15n	30	120	800	2	330	8 K	3.5	70	200	2	4.5		92	
BD127	P	S	N	17.5W	150	300	250	500	50n	150	30		50									126	
BD128	P	S	N	17.5W	150	350	300	500	50n	150	30		50									126	
BD129	P	S	N	17.5W	150	400	350	500	50n	150	30		50									126	
BD135	AF	S	N	1W	150	45	45	1A	100n	30	45	250	150	250			50					126	
BD136	AF	S	P	1W	150	45	45	1A	100n	30	40	250	150	250			50					126	
BD137	AF	S	N	1W	150	60	60	1A	100n	30	40	160	150	160			50					126	
BD138	AF	S	P	1W	150	60	60	1A	100n	30	40	180	150	160			50					126	
BD139	AF	S	N	1W	150	80	80	1A	100n	30	40	160	150	160			50					126	
BD140	AF	S	P	1W	150	80	80	1A	100n	30	40	180	150	150			50					126	
BD165	AF	S	N	20W	150	45	45	1.5A	100	45	40		150				3					126	
BD166	AF	S	P	20W	150	45	45	1.5A	100	45	40		150				3					126	
BD167	AF	S	N	20W	150	60	60	1.5A	100	60	40		150				3					165	
BD168	AF	S	P	20W	150	60	60	1.5A	100	60	40		150				3					165	
BD169	AF	S	N	20W	150	80	80	1.5A	100	80	40		150				3					165	
BD170	AF	S	P	20W	150	80	80	1.5A	100	80	40		150				3					165	
BD213-45	P	S	N	90W	150	45	45	15A	500	45	40		1.5A				3						
BD213-60	P	S	N	90W	150	60	60	15A	500	60	40		1.5A				3						
BD213-80	P	S	N	90W	150	80	80	15A	500	80	40		1.5A				3						
BD214-45	P	S	P	90W	150	45	45	15A	500	45	40		1.5A				3						
BD214-60	P	S	P	90W	150	60	60	15A	500	60	40		1.5A				3						
BD214-80	P	S	P	90W	150	80	80	15A	500	80	40		1.5A				3						
BD233	P	S	N	25W	150	45	45	2A	100	45	40		150				3					126	
BD234	P	S	P	25W	150	45	45	2A	100	45	40		150				3					126	
BD235	P	S	N	25W	150	60	60	2A	100	60	40		150				3					126	
BD236	P	S	P	25W	150	60	60	2A	100	60	40		150				3					126	
BD237	P	S	N	25W	150	80	80	2A	100	80	40		150				3					126	
BD238	P	S	P	25W	150	80	80	2A	100	80	40		150				3					126	
BD585	P	S	N	42W	150	45	45	4A	100	45	40		500				3					126	
BD586	P	S	P	42W	150	45	45	4A	100	45	40		500				3					126	
BD587	P	S	N	42W	150	60	60	4A	100	60	40		500				3					126	
BD588	P	S	P	42W	150	60	60	4A	100	60	40		500				3					126	
BD589	P	S	N	42W	150	80	80	4A	100	80	30		500				3					126	
BD590	P	S	P	42W	150	80	80	4A	100	80	30		500				3					126	
BD595	P	S	N	55W	150	45	45	8A	100	45	40		1A				3						
BD596	P	S	P	55W	150	45	45	8A	100	45	40		1A				3						
BD597	P	S	N	55W	150	60	60	8A	100	60	40		1A				3						
BD598	P	S	P	55W	150	60	60	8A	100	60	40		1A				3						
BD599	P	S	N	55W	150	80	80	8A	100	80	30		1A				3						
BD600	P	S	P	55W	150	80	80	8A	100	80	30		1A				3						

TYPE	TOSHIBA	NEC	HITACHI	mitsubishi	MATSUSHITA	FUJITSU	SONY	SANYO	NOTE
BC238					2SC619				
BC239					2SC619				
BC307	2SA522A	2SA710	2SA548						
BC308	2SA522A	2SA710							
BC309	2SA402	2SA710							
BC327					2SA731				
BC328				2SA695	2SA730				
BC337	2SC495		2SC1214			2SC968			
BC338	2SC509		2SC1214			2SC967			
BC413		2SC1330		2SC1313					
BC414		2SC1330		2SC1313					
BC415	2SA561			2SA726	2SA550 A		2SA705		
B 416	2SA561			2SA726			2SA705		
BD127	2SC782					2SC825			
BD128			2SC833				2SC867		
BD129			2SC833				2SC867		
BD135				2SC816					
BC136		2SA715			2SA752		2SA706		
BD137	2SC513		2SC708	2SC816		2SC1052			
BD138		2SA715			2SA752		2SA762		
BD139	2SC512		2SC708A	2SC776		2SC1069	2SC1124		
BD140							2SA762		
BD165				2SC737					
BD166	2SA490		2SA670						
BD167				2SC737		2SC865			
BD168	2SA740	2SA616							
BD169	2SC779			2SC766					
BD170	2SA740	2SA616							
BD213-45	2SD114					2SD231			
BD213-60	2SD114		2SD341			2SD232	2SD339		
BD213-80	2SD113	2SD181	2SD341			2SD232	2SD339		
BD214-45			2SB332	2SB478					
BD214-60			2SB332	2SB478			2SB519		
BD214-80			2SB333	2SB479			2SB519		
BD233		2SC290			2SC646				
BD234	2SB434				2SB513			2SB216	
BD235		2SC290			2SC646				
BD236					2SB513			2SB215	
BD237			2SC679						
BD238									
BD585	2SC521A	2SC244							
BD586		2SB251A			2SB129				
BD587	2SC520	2SC244			2SC647				
BD588		2SB251A	2SB228		2SB129	2SB151			
BD589	2SC520	2SC245	2SC664		2SC647				
BD590		2SB253	2SB228		2SB129	2SB151			
BD595	2SD111		2SD124 A						
BD596	2SB531								
BD597	2SD111		2SD124 A						
BD598	2SB531								
BD599	2SD111			2SC889		2SC902			
BD600	2SB531								

TYPE	MATERIAL	POLARITY	MAXIMUM RATINGS					ELECTRICAL CHARACTERISTICS											OUTLINE TO-	NOTE				
			Pc 25°C (mW)	Tj (°C)	V _{GR} (V)	V _{GS0} (V)	I _C (mA)	I _{CEO} (μA)	V _{GS(V)}	f _{min}	f _{max}	I _C (mA)	h _{FE}	h _{FE}	h _{ie} (Ω)	h _{re} (×10)	h _{oe} (μS)	f _T at I _C = I _{CEO} (MHz)			NF (dB)	C _{ob} (pF)	C _{strb} (ps)	
BD675	P	S	N	40W	150		45	4 A				50		2 A										SOT 32
BD676	P	S	P	40W	150		45	4 A				50		2 A										SOT 32
BD677	P	S	N	40W	150		60	4 A				50		2 A										SOT 32
BD678	P	S	P	40W	150		60	4 A				50		2 A										SOT 32
BD679	P	S	N	40W	150		80	4 A				50		1.5A										SOT 32
BD680	P	S	P	40W	150		80	4 A				50		1.5A										SOT 32
BD695	P	S	N	70W	150		45	5 A				250		4 A										TOP 66
BD696	P	S	P	70W	150		45	5 A				250		4 A										TOP 66
BD697	P	S	N	70W	150		60	5 A				250		4 A										TOP 66
BD698	P	S	P	70W	150		60	5 A				250		4 A										TOP 66
BD699	P	S	N	70W	150		80	5 A				250		3 A										TOP 66
BD700	P	S	P	70W	150		80	5 A				250		3 A										TOP 66
BD701	P	S	N	70W	150		100	5 A				250		3 A										TOP 66
BD702	P	S	P	70W	150		100	5 A				250		3 A										TOP 66
BF115	HF	S	N	145	175	50	30	30	0.5	20	40			20				230	1.5	0.8				72
BF167	HF	S	N	130	175	40	30	25			27	57	4					350	3	1.5				72
BF173	HF	S	N	200	175	40	25	25			38	90	7					550		2.3				72
BF177	HF	S	N	600	200		100	50			20		30					120		1.8	25	5		TV
BF178	HF	S	N	600	200		185	50			20		30					120		1.8	25	5		TV
BF179A	HF	S	N	600	200		185	50			20		20					120		1.8	25	5		TV
BF179B	HF	S	N	600	200		220	50			20		20					120		1.8	25	5		TV
BF179C	HF	S	N	600	200		250	50			20		20					120		1.8	25	5		TV
BF184	HF	S	N	145	175	30	20	30			67	220	1					260			3.5			72
BF185	HF	S	N	145	175	30	20	30			36	125	1					200						72
BF194	HF	S	N	300	150	30	20	30			67	220	1					260						SOT 25
BF254	HF	S	N	300	150	30	20	30			67	220	1					260						92
BF195	HF	S	N	300	150	30	20	30			36	125	1					200						SOT 25
BF255	HF	S	N	300	150	30	20	30			36	125	1					200						92
BF196	HF	S	N	300	150	40	30	25			27	80	4					400	3					SOT 25
BF198	HF	S	N	300	150	40	30	25			27	80	4					400	3					92
BF197	HF	S	N	300	150	40	25	25			38	88	7					550						TV
BF199	HF	S	N	300	150	40	25	25			38	88	7					550						TV
BF223	HF	S	N	360	150	35	25	40	50n	20	40	79	15					750						SOT 25
BF311	HF	S	N	360	150	35	25	40	50n	20	40	79	15					750						92
BF227	HF	S	N	50	125	40	25	25			30	100	3					600						TOP 23
BF228	HF	S	N	50	125	100	90	50	100n	75	30		2					50						TOP 23
BF229	HF	S	N	50	125	30	20	30			67	220	1					260						TOP 23
BF230	HF	S	N	50	125	30	20	30			36	125	1					200						TOP 23
BF240	HF	S	N	300	150	40	40	25	100n	20	67	220	1					430						92
BF241	HF	S	N	300	150	40	40	25	100n	20	36	125	1					400						92
BF257	HF	S	N	5W	175	160	160	100	50n	100	25		30					90						39
BF258	HF	S	N	5W	175	250	250	100	50n	200	25		30					90						39
BF259	HF	S	N	5W	175	300	300	100	50n	250	25		30					90						39
BF310	HF	S	N	300	150	30	30	25	60n	20	29		4					580						92
BF314	HF	S	N	300	150	30	30	25	60n	20	29		4					450						92
BF377	HF	S	N	300	150	30	15	25	10n	15	25	90	2					(MHz)						92 →特D!
BF378	HF	S	N	300	150	30	15	25	10n	15	25	90	2					(MHz)						92 →特D!
BF379	HF	S	P	300	150	40	25	25	50n	20	80		1					350						92
BF414	HF	S	P	300	150	40	30	25	60n	20	30	80	1					400						92
BF440	HF	S	P	300	150	40	40	25	100n	20	60	220	1					250						92
BF441	HF	S	P	300	150	40	40	25	100n	20	30	125	1					250						92
BUI05		S	N	10W	115	750	750	2.5A										7.5						3
BUI08		S	N	12.5W	115	1500	750	5A										7						3

TYPE	TOSHIBA	NEC	HITACHI	mitsubishi	MATSUSHITA	FUJITSU	SONY	SANKEN	NOTE
BD675	2SD371		2SD124	2SD26A					
BD676								2SA764	
BD677	2SD371		2SD124	2SD26A			2SD47		
BD678	2SA658	2SA626	2SB361	2SB358				2SA764	
BD679	2SD371	2SD180		2SD26B			2SD47		
BD680	2SB531	2SA626	2SB361	2SB358		2SB432			
BD695		2SC851		2SC1020					
BD696			2SB332			2SB352			
BD697	2SD111			2SC1020			2SD88		
BD698							2SB518		
BD699	2SD111	2SD322			2SD334		2SD88		
BD700	2SA680					2SB353	2SB518	2SA744	
BD701	2SD111	2SD322	2SC898		2SD334	2SC902	2SD88		
BD702								2SA745	
BF115	2SC383	2SC1009	2SC907A						
BF167	2SC382		2SC907A						
BF173	2SC382		2SC907A						
BF177	2SC983						2SC353		
BF178	2SC983								
BF179A	2SC983								
BF179B	2SC983								
BF179C	2SC983								
BF184		2SC1044				2SC811			
BF185		2SC1044				2SC811			
BF194		2SC899							
BF254		2SC899							
BF195		2SC899		2SC710					
BF255		2SC899		2SC710					
BF196		2SC1187							
BF198		2SC1187							
BF197		2SC1187							
BF199		2SC1187							
BF223					2SC1303				
BF311					2SC1303				
BF227									
BF228									
BF229									
BF230									
BF240		2SC1188							
BF241		2SC1188							
BF257	2SC515		2SC685						
BF258	2SC515		2SC685						
BF259	2SC515		2SC685						
BF310		2SC1188	2SC684						
BF314		2SC1188	2SC684						
BF377			2SC684		2SC583				
BF378			2SC684		2SC583				
BF379			2SA548						
BF414			2SA548						
BF440		2SA578							
BF441		2SA578							
BU105	2SC643		2SC937	2SC1153					
BU108		2SC1358		2SC1309	2SD300				

SIEMENS

SIEMENS

TYPE	MATERIAL	POLARITY	MAXIMUM RATINGS						ELECTRICAL CHARACTERISTICS											OUTLINE TO:	NOTE		
			Pc 25°C (mW)	Tj (°C)	Va (V)	V _{ceo} (V)	Ic (mA)	I _{ceo} (μA)	V _{ce(V)}	I _{ce} min.	I _{ce} max.	Ic(mA)	hfe	h _{ie} (Ω)	h _{re} (×10)	h _{oe} (μS)	f _T *f _{β0} (MHz)	NF (dB)	Cob (pF)			C _{ext} (ps)	
AC121	LF	G	P	900	90	20	20	300		5		30	190	100				1.5	4	27		I	
AC127	LF	G	N	340	90	32	32	500	10		50	100	500				2.5	10	70		I		
AC151r	LF	G	P	900	90	32	24	200			40		200				1.5	3	25		I		
AC152	LF	G	P	900	90	32	24	500			75		100				1.5	25	15		I		
AC153	LF	G	P	1 W	90	32	18	2 A	10	10	68	173	1 A				1.5		100		I	AC176CONPI	
AC153K	LF	G	P	1 W	90	32	18	2 A	10	10	68	173	1 A				1.5		100		K	□形	
AC162	LF	G	P	900	90	32	24	200	10	10	100		50				1.7	4	25		I		
AC163	LF	G	P	900	90	32	24	200	10	10	132		50				2.3	4	25		I		
AC176	P	G	N	1 W	90	32	18	1 A	7	10	50	250	300				3		100		I	AC153CONPI	
AC176K	P	G	N	1 W	90	32	18	1 A	7	10	50	250	300				3		100		K	□形	
AC187K	P	G	N	1 W	90	25	15	2 A	7	10	100	500	300				5		100		K	□形	
AC188K	P	G	P	1 W	90	25	15	2 A	20	10	100	500	300				1.5		100		K	□形	
AD130	S	G	P	30W	90	32	30	3 A			20	40	1 A						200		3		
AD131	S	G	P	30W	90	64	45	3 A			20	40	1 A						200		3		
AD132	S	G	P	30W	90	80	60	3 A			20	40	1 A						200		3		
AD133	S	G	P	36W	100	50	20	15A			50	100	5 A								41		
AD136	S	G	P	11W	100	40	20	10A			75	150	5 A								8		
AD148	P	G	P	13.5W	100	32	26	3.5A	1.2 m	10	50	100	1 A										
AD149	P	G	P	27.5W	100	50	30	3.5A			50	100	1 A									3	
AD150	P	G	P	27.5W	100	32	30	3.5A			50	100	1 A									3	
AD161	P	G	N	4 W	90	32	20	3 A	20	32	50	350	500				3		100		SGT 9		
AD162	P	G	P	6 W	90	32	20	3 A	7	20	175	350	500				1.5		100		SGT 9		
AD163	P	G	P	30W	90	100	80	3 A			30	60	1 A				300 kHz		200		3		
AF106	MIX	G	P	60	90	25	18	10	0.5	12	70		2	65			220	5.5		6	72		
AF109R	AGC	G	P	60	90	20	15	10	0.5	20	55		2						4			72	
AF139	MIX	G	P	60	90	20	15	10	0.5	20	55		2				550	7.5		3	72		
AF200	HF	G	P	225	90	25	25	10	0.5	12	85		3	150							6	72	
AF201	HF	G	P	225	90	25	25	10	0.5	12	85		3	150							6	72	
AF200U	HF	G	P	60	90	25	25	10	0.5	12	85		3	150							6	72	
AF201U	HF	G	P	60	90	25	25	10	0.5	12	85		3	150							6	72	
AF202	HF	G	P	225	90	25	25	30	0.4	12	85		3	150							6	72	
AF202S	HF	G	P	225	90	32	32	30	0.4	12	85		3	150							6	72	
AF239	UHF	G	P	60	90	20	15	10			50		2				700	5				72	
AF239S	OSC	G	P	60	90	20	15	10			50		2				780	5				72	
AF240	HF	G	P	60	90	20	15	10			25		2				500	6.5				72	
AF279	UHF	G	P	60	90	20	15	10			50		2				780	5				50	
AF280	UHF	G	P	60	90	20	15	10			25		2				550	7				50	
BC107	AF	S	N	300	175	50	45	200			380	800	2				250					18	
BC108	AF	S	N	300	175	30	20	200			380	800	2				250					18	
BC109	AF	S	N	300	175	30	20	50			380	800	2				300					18	
BC110	AF	S	N	300	175	80	80	50	100 n	80	90		2				100		5			18	
BC121	AF	S	N	250	150	5	5	75	10n	2	125	620	10				250	2.5	4.4		U32PI	*	
BC122	AF	S	N	250	150	30	20	75	10n	15	125	620	10				250	2.5	3.5		U32PI		
BC123	AF	S	N	250	150	45	30	75	10n	25	125	620	10				250	2.5	3.5		U32PI		
BC140	AF	S	N	3.7W	175	80	40	1A			63	160	100				50		25			39	
BC141	AF	S	N	3.7W	175	100	60	1A			63	160	100				50		25			39	
BC147	AF	S	N	300	175	50	45	200			180	460	2				250						
BC148	AF	S	N	300	175	30	20	200			180	460	2				250						
BC149	AF	S	N	300	175	30	20	50			380	800	2				300						
BC157	AF	S	P	300	150	50	45	200			170	290	2				130	10	6			SGT 25	
BC158	AF	S	P	300	150	30	25	200			170	500	2				130	10	6			SGT 25	
BC159	AF	S	P	300	150	25	20	50			170	500	2				130	4	6				
BC160	AF	S	P	3.7W	175	40	40	1A			63	160	100				50		30			39	
BC161	AF	S	P	3.7W	175	60	60	1A			63	160	100				50		30			39	
BC167	AF	S	N	300	150	50	45	200			170	290	2				250	2	45			92	

TYPE	TOSHIBA	NEC	HITACHI	MITSUBISHI	MATSUSHITA	FUJITSU	SONY	SANYO	NOTE
AC121	2SA594				2SA374				
AC127	2SC366		2SC1213						
AC151r	2SA594				2SA374				
AC152	2SA504								
AC153		2SB504		2SB495					
AC153K		2SB504		2SB495					
AC162		2SB504		2SB495					
AC163		2SB504		2SB495					
AC176		2SC1266				2SC1069			
AC176K		2SC1266				2SC1069			
AC187K				2SC778					
AC188K		2SA633			2SA699				
AD130	2SB503	2SB107A		2SB138	2SB126			2SB507	
AD131	2SB503				2SB128				
AD132	2SB502				2SB128				
AD133	2SB124								
AD136	2SB296		2SB85						
AD148	2SB503				2SB513			2SB216	
AD149	2SB503				2SB513				
AD150	2SB503				2SB513				
ADI61	2SC490				2SC585	2SC592			
ADI62	2SB502		2SB83						
ADI63	2SB64								
AF106	2SA494	2SA244			2SA249	2SA113			
AF109R	2SA495		2SA84			2SA113			
AF139	2SA495		2SA84						
AF200	2SA495		2SA86						
AF201	2SA495		2SA86						
AF200U	2SA495		2SA84		2SA100				
AF201U	2SA495		2SA84		2SA100				
AF202	2SA495	2SA244							
AF202S	2SA494	2SA244			2SA249	2SA113			
AF239		2SA244	2SA390		2SA310				
AF239S		2SA244	2SA390		2SA310				
AF240		2SA244	2SA390		2SA310				
AF279		2SA244	2SA390		2SA310				
AF280		2SA244	2SA389		2SA310				
BC107	2SC559					2SC565			
BC108	2SC559					2SC565			
BC109			2SC154		2SC538A	2SC565			
BC110				2SC307					
BC121	2SC732			2SC711					
BC122	2SC732			2SC711					
BC123	2SC734			2SC711					
BC140	2SC523			2SC1018					
BC141	2SC524								
BC147	2SC503								
BC148	2SC504								
BC149	2SC504								
BC157	2SA503								
BC158	2SA504								
BC159	2SA504								
BC160	2SB462					2SB445			
BC161	2SB462					2SB446			
BC167	2SB503			2SC871					

TYPE	MATERIAL	POLARITY	MAXIMUM RATINGS						ELECTRICAL CHARACTERISTICS										OUTLINE TO:	NOTE			
			Pc 25°C (mW)	Tj (°C)	V _{oa} (V)	V _{om} (V)	I _c (mA)	I _{ceo} (μA)	V _{ce(V)}	f _{min}	f _{max}	I _c (mA)	h _{FE}	h _{FE}	h _{FE}	h _{FE}	h _{FE}	h _{FE}			h _{FE}	h _{FE}	h _{FE}
BC168	AF	S	N	300	150	20	100			170	500	2						250	2	4.5		92	
BC169	AF	S	N	300	150	30	20	50			290	500	2					300	4	4.5		92	
BC177	AF	S	P	300	175	50	45	100			170	290	2					130	10	4.5		18	
BC178	AF	S	P	300	175	30	25	100			170	500	2					130	10	4.5		18	
BC179	AF	S	P	300	175	25	20	50			170	500	2					130	4	4.5		18	
BC182	AF	S	N	300	150	60	50	200	15 n	50	170	290	2					150	2	2.5		92	*
BC201	AF	S	P	250	150	5	5	75	2 n	2	75	290	0.2					200	2.5	5.4		U32PI	
BC202	AF	S	P	250	150	30	20	75	2 n	15	75	175	0.2					200	2.5	3.5		U32PI	
BC203	AF	S	P	250	150	45	30	75	2 n	25	75	175	0.2					200	2.5	3.5		U32PI	
BC212	AF	S	P	300	150	60	50	200	15 n	30	170	290	2					200	2	4		92	*
BC237	AF	S	N	300	150	50	45	100			170	290	2					250	2	4.5		92	
BC238	AF	S	N	300	150	30	20	100			170	500	2					250	2	4.5		92	
BC239	AF	S	N	300	150	30	20	50			170	500	2					300	4	4.5		92	
BC257	AF	S	P	300	150	50	45	100			170	290	2					130	10	6		92	
BC258	AF	S	P	300	150	30	25	100			170	500	2					130	10	6		92	
BC259	AF	S	P	300	150	25	20	50			170	500	2					130	4	6		92	
BC307	AF	S	P	300	150		45	100			170	290	2					130	10	6		92	
BC308	AF	S	P	300	150		25	100			170	290	2					130	10	6		92	
BC309	AF	S	P	300	150		20	50			290	500	2					130	4	6		92	
BC327	AF	S	P	1.4 W	150		45	800			160	400	100					100		12		SOT 30	*
BC328	AF	S	P	1.4 W	150		25	800			160	400	100					100		12		SOT 30	*
BC337	AF	S	N	1.4 W	150		45	800			100	400	100					100		12		SOT 30	*
BC338	AF	S	N	1.4 W	150		25	800			100	400	100					100		12		SOT 30	*
BC413	AF	S	N	300	150	45	30	100	15 n	30	290	500	2					250	2.5	2.5		92	*
BC414	AF	S	N	300	150	50	45	100	15 n	30	290	500	2					250	2.5	2.5		92	*
BC415	AF	S	P	300	150	45	35	100	15 n	30	170	500	2					200	2	4.5		92	* lownoise
BC416	AF	S	P	300	150	50	45	100	15 n	30	170	500	2					200	2	4.5		92	* lownoise
BD109	SW	S	N	18.5 W	175	60	40	3 A	10 n	40	63	160	1 A					30		35		SOT 9	
BD130	P	S	N	100 W	200	100	60	15 A			20	70	4 A					1.1				3	
BD135	AF	S	N	12.5 W	150	45	45	1.5 A	100 n	30	63	160	500					50				SOT 32	
BD136	AF	S	P	12.5 W	150	45	45	1.5 A	100 n	30	63	160	500					75				SOT 32	
BD137	AF	S	N	12.5 W	150	60	60	1.5 A	100 n	30	63	100	500					50				SOT 32	
BD138	AF	S	P	12.5 W	150	60	60	1.5 A	100 n	30	63	100	500					75				SOT 32	
BD139	AF	S	N	12.5 W	150		80	1.5 A	100 n	30	63	100	500					50				SOT 32	*
BD140	AF	S	P	12.5 W	150		80	1.5 A	100 n	30	63	100	500					75				SOT 32	*
BD148	P	S	N	31 W	200	60	40	4 A			63	160	500					1				66	
BD149	AF	S	N	31 W	200	80	60	4 A			63	100	500					1				66	*
BD233	P	S	N	25 W	150	45	45	2 A	100	45	40		150					3		60		SOT 32	*
BD234	P	S	P	25 W	150	45	45	2 A	100	45	40		150					3		60		SOT 32	*
BD235	P	S	N	25 W	150	60	60	2 A	100	60	40		150					3		60		SOT 32	*
BD236	P	S	P	25 W	150	60	60	2 A	100	100	40		150					3		60		SOT 32	*
BD237	P	S	N	25 W	150	100	80	2 A	100	100	40		150					3		60		SOT 32	*
BD238	P	S	P	25 W	150	100	80		100	100	40		150					3		60		SOT 32	*

TYPE	TOSHIBA	NEC	HITACHI	MITSUBISHI	MATSUSHITA	FUJITSU	SONY	SANYO	NOTE
BC168		2SC764		2SC871		2SC727			
BC169		2SC764				2SC727			
BC177		2SA603			2SA550A				
BC178		2SA603			2SA550A				
BC179					2SA666				
BC182				2SC446					
BC201	2SA522		2SA373		2SA550				
BC202		2SA710			2SA550A				
BC203		2SA710							
BC212		2SA712							
BC237			2SC111			2SC136			
BC238	2SC74					2SC134			
BC239	2SC103A					2SC172A			
BC257	2SA561	2SA710		2SA697					
BC258	2SA561	2SA710		2SA696					
BC259	2SA562			2SA696					
BC307		2SA710		2SA697					
BC308		2SA710		2SA696					
BC309	2SA502								
BC327		2SA614		2SB526	2SA752				
BC328		2SA614		2SB526	2SA752				
BC337		2SC781		2SC777		2SC798			
BC338		2SC781		2SC777		2SC798			
BC413	2SC734	2SC896							
BC414	2SC734	2SC896							
BC415	2SA561	2SA718							
BC416	2SA561	2SA718							
BD109	2SC493			2SD58			2SD29		
BD130	2SD113					2SD232			
BD135				2SD58			2SD29		
BD136					2SB512			2SB514	
BD137	2SC490								
BD138	2SB503	2SB505			2SB512				
BD139	2SD102		2SC1055						
BD140	2SB502								
BD148	2SD107							2SD315	
BD149	2SD107	2SD180							
BD233	2SD103	2SD285						2SD313	
BD234	2SB434				2SB512			2SB507	
BD235	2SD130	2SD285						2SD313	
BD236	2SB531								
BD237		2SD285				2SC1031		2SD61	
BD238	2SB530	2SB506		2SD59		2SB432		2SB491	

SIEMENS

TYPE	USE	MATERIAL	POLARITY	MAXIMUM RATINGS							ELECTRICAL CHARACTERISTICS											OUTLINE TO:	NOTE
				Pc 25°C (mW)	Tj (°C)	Vca (V)	Vcap (V)	Ic (mA)	Icao (μA)	Vca(V)	hfe min.	hfe max.	Ic(mA)	hfe	hie (Ω)	hre (×10 ³)	hoe (μs)	f _T f _{oe} f ₁₀₀ (MHz)	NF (dB)	Cob (pF)	Coxtrb (ps)		
BF111	HF	S	N	3 W	175		200	80										120		1.8	100	39	
BF167	HF	S	N	130	175	40	30	25										350	3	0.15		39	
BF173	HF	S	N	260	175	40	25	25										550		0.23		39	
BF177	HF	S	N	2.9W	175	100	100	40	200 n	100	20		15					120			100	39	
BF178	HF	S	N	2.9W	175	160	185	50	200 n	160	20		30					120			100	39	
BF179A	HF	S	N	2.9W	175	160	185	50	200 n	160	20		20					120		1.3	100	39	
BF179B	HF	S	N	2.9W	175	220	220	50	200 n	160	20		20					120		1.3	100	39	
BF179C	HF	S	N	2.9W	175	250	250	50	200 n	160	20		20					120		1.3	100	39	
BF194	HF	S	N	220	125	30	20	30				115	1					260	1.5			25	
BF195	HF	S	N	220	125	30	20	30				67	1					200	3.5			25	
BF198	HF	S	N	500	150	40	30	25	100 n	40	70		4					400	3	0.22		92	*
BF199	HF	S	N	500	150	40	25	25	100 n	40	85		7					550		0.32		92	*
BF240	HF	S	N	250	150	40	40	25	100 n	20								400	1.7			92	*
BF241	HF	S	N	250	150	40	40	25	100 n	20								400	1.7			92	*
BF254	HF	S	N	220	120	30	20	30				115	1					260	1.5			92	
BF255	HF	S	N	220	120	30	20	30				67	1					200	3.5			92	
BF257	AF	S	N	5W	175	160	160	100	50 n	100	25		30					90		4.2		39	
BF258	AF	S	N	5W	175	250	250	100	50 n	200	25		30					90		4.2		39	
BF259	AF	S	N	5W	175	300	300	100	50 n	250	25		30					90		4.2		39	*
BF310	HF	S	N	300	150	30	30	25	60 n	20								580					SOT 30 *
BF314	HF	S	N	300	150	30	30	25	60 n	20								580	2				SOT 30 *
BF324	HF	S	P	250	150	30	30	25	50 n	30	50		4					440	3				SOT 30 *
BF450	HF	S	P	150	125	40	40	25	50 n	30	60		1					375	2				SOT 30 *
BF451	HF	S	P	150	125	40	40	25	50 n	30	30		1					325	2				SOT 30 *
BF457	AF	S	N	1.2W	150	160	160	100	50 n	100	25		30					90					SOT 32 *
BF458	AF	S	N	1.2W	150	250	250	100	50 n	200	25		30					90					SOT 32 *
BF459	AF	S	N	1.2W	150	300	300	100	50 n	250	25		30					90					SOT 32 *
BUI10	SW	S	N	60W	175	330	150	10A				5	7 A					25				3	
BUI11	SW	S	N	50W	150	400	300	6 A				5	3 A					20				3	
BUI14	SW	S	N	50W	150	250	150	6 A				5	3 A					20				3	*

FAIRCHILD

FAIRCHILD

TYPE	USE	MATERIAL	POLARITY	MAXIMUM RATINGS					ELECTRICAL CHARACTERISTICS													OUTLINE TO.	NOTE
				Pc 25°C (mW)	Tj (°C)	Vca (V)	Vceo (V)	Ic (mA)	Icbo (μA)	Vce(V)	hFE		hfe	hie (Ω)	hre (x10)	hoe (μS)	fT *fmax (MHz)	NF (dB)	Cob (pF)	Coaxbb (ps)			
BC113	A	S	N	200	125	30	25	50	0.5	20	200	1000	1.0	400	10K	4.2	20		2.5	2.7		18	
BC114	A	S	N	200	125	30	25	50	0.5	20	200	1000	1.0	400	10K	4.2	20		1.5	2.7		18	
BC115	A	S	N	300	125	40	30	200	0.1	20	100	400	10							25		5	
BC116A	A	S	P	300	125	45	40		0.05	20	80	240	150	70			130			10		5	
BC119	A	S	N	800	200	60	30		0.05	40	40	120	150	2.0						25		5	
BC139	A	S	P	700	200	40	40	500	0.05	30	40		100									5	
BC125	A	S	N	240	125	50	30		0.05	20	30		50	2.0						25		5	
BC126	A	S	P	240	125	35	30	600	0.05	20	30	120	150									5	
BC140	A	S	N	650	175		40	1000			40	400	100				50					5	
BC141	A	S	N	650	175		60	1000			40	400	100				50					5	
BC142	A	S	N	800	200	80	60	1000	0.05	40	20		200									5	
BC143	A	S	P	800	200	60	60	1000	0.05	30	20		300									5	
BC153	A	S	P	200	125	40	40	100	0.05	30	50		0.1									18	
BC154	A	S	P	200	125	40	40	100	0.05	30	160		0.1						2.5			18	
BC160	A	S	N	650	175		40	1000			40	400	100				50					5	
BC161	A	S	P	650	175		60	1000			40	400	100				50					5	
BC204V1	A	S	P	200	125	50	45		0.05	45	50	120	2					10				18	
BC204A	A	S	P	200	125	50	45		0.05	45	110	220	2					10				18	
BC204B	A	S	P	200	125	50	45		0.05	45	200	450	2					10				18	
BC205A	A	S	P	200	125	25	20		0.05	20	110	220	2					10				18	
BC205B	A	S	P	200	125	25	20		0.05	20	200	450	2					10				18	
BC205C	A	S	P	200	125	25	20		0.05	20	400	800	2					10				18	
BC206B	A	S	P	200	125	25	20		0.05	20	200	450	2					4				18	
BC206C	A	S	P	200	125	25	20		0.05	20	400	800	2					4				18	
BC207A	A	S	N	200	125	50	45	100	0.015	40	110	220	2					10	6			18	
BC207B	A	S	N	200	125	50	45	100	0.015	40	200	450	2					10	6			18	
BC208A	A	S	N	200	125	25	25	100	0.015	20	110	220	2					10	6			18	
BC208B	A	S	N	200	125	25	25	100	0.015	20	200	450	2					10	6			18	
BC208C	A	S	N	200	125	25	25	100	0.015	20	420	800	2					10	6			18	
BC209B	A	S	N	200	125	25	25	100	0.015	20	200	450	2					4	6			18	
BC209C	A	S	N	200	125	25	25	100	0.015	20	420	800	2					4	6			18	
BC225	A	S	P	200	125	40	40	100	0.05	30	90		0.1									18	
BC286	A	S	N	800	200	70	60	1000	0.02	30	20	180	500	25						12		5	
BC287	A	S	N	800	200	60	60	1000	0.05	30	20	200	500	75						20		5	
BC317A	A	S	N	625	150	50	45	150	0.03	20	110	220	2	300					6	4		92	
BC318A	A	S	N	625	150	45	30	150	0.03	20	110	220	2	450					6	4		92	
BC317B	A	S	N	625	150	50	45	150	0.03	20	200	450	2	300					6	4		92	
BC318B	A	S	N	625	150	45	30	150	0.03	20	200	450	2	450					6	4		92	
BC318C	A	S	N	625	150	45	30	150	0.03	20	420	800	2	500					6	4		92	
BC319B	A	S	N	625	150	30	20	150	0.03	20	200	450	2	500					4	4		92	
BC319C	A	S	N	625	150	30	20	150	0.03	20	420	800	2	500					4	4		92	
BC320A	A	S	P	625	150	50	45	150	0.03	20	110	220	2	300					6	4		92	
BC320B	A	S	P	625	150	50	45	150	0.03	20	200	450	2	300					6	4		92	
BC321A	A	S	P	625	150	45	30	150	0.03	20	110	220	2	500					6	4		92	
BC321B	A	S	P	625	150	45	30	150	0.03	20	200	450	2	500					6	4		92	
BC321C	A	S	P	625	150	45	30	150	0.03	20	400	800	2	500					6	4		92	
BC322B	A	S	P	625	150	30	20	50	0.03	20	200	450	2	600					4	4		92	
BC322C	A	S	P	625	150	30	20	50	0.03	20	400	800	2	600					4	4		92	
BC323	A	S	N	7W	200	100	60	5A	100	100	45	225	50	5						80		5	
BC520	A	S	N	625	150	60	60	50	0.002	45	180	800	10	600	8.5K	7	24			6		92	
BC521	A	S	N	625	150	45	45	50	0.002	30	380	1550	10	1300	28K	23	74			8		92	
BC520B	A	S	N	625	150	60	60	50	1.002	45	180	460	10	600	8.5K	7	24			8		92	
BC520C	A	S	N	625	150	60	60	50	0.002	45	380	800	10	600	8.5K	7	24			8		92	
BC521C	A	S	N	625	150	45	45	50	0.002	30	380	800	10	1300	28K	23	74			8		92	
BC521B	A	S	N	625	150	45	45	50	0.002	30	750	1550	10	1300	28K	23	74			8		92	

TYPE	TOSHIBA	NEC	HITACHI	MTSUBISHI	MATSUSHITA	FUJITSU	SONY	SANYO	NOTE
BC113			2SC350				2SC631A	2SC693	
BC114			2SC350				2SC631A	2SC693	
BC115		2SC32	2SC110	2SC306		2SC202			
BC116A	2SA661	2SA545		2SA697					
BC119	2SC486								
BC139	2SA486		2SA743						
BC125	2SC1626	2SC596				2SC596			
BC126	2SA682			2SA697					
BC140	2SC524								
BC141	2SC524								
BC142	2SC516								
BC143	2SA681								
BC153							2SA705		
BC154							2SA705		
BC160	2SA512								
BC161	2SA512								
BC204V1			2SA672						
BC204A			2SA672						
BC204B			2SA672						
BC205A					2SA666				
BC205B					2SA666				
BC205C					2SA666				
BC206B					2SA666				
BC206C					2SA666				
BC207A	2SC1000								
BC207B	2SC1000								
BC208A			2SC350						
BC208B			2SC350						
BC208C			2SC350						
BC209B			2SC350						
BC209C			2SC350						
BC225							2SA705		
BC286		2SC1098							
BC287		2SA636							
BC317A						2SC969			
BC318A						2SC969			
BC317B						2SC969			
BC318B						2SC969			
BC318C						2SC969			
BC319B						2SC969			
BC319C						2SC969			
BC320A									
BC320B									
BC321A							2SA705		
BC321B							2SA705		
BC321C									
BC322B				2SA725	2SA774			2SA701	
BC322C				2SA725	2SA774			2SA701	
BC323	2SC492						2SC43		
BC520						2SC969			
BC521						2SC969			
BC520B						2SC969			
BC520C						2SC969			
BC521C						2SC969			
BC521D						2SC969			

FAIRCHILD

TYPE	USE	MATERIAL	POLARITY	MAXIMUM RATINGS											ELECTRICAL CHARACTERISTICS										OUTLINE TO.	NOTE			
				Pc 25°C (mW)	Tj (°C)	V _{ce} (V)	V _{ceo} (V)	I _c (mA)	I _{ceo} (μA)		h _{FE}		h _{FE}	h _{ie} (Ω)	h _{re} (×10)	h _{oe} (μC)	f _T *f _{res} **f _{res} (MHz)	NF (dB)	C _{ob} (pF)	C _{ovbb} (ps)									
BC522C	A	S	N	625	150	20	20	50	10n	20	400	800	2.0											92					
BC522D	A	S	N	625	150	20	20	50	10n	20	750	1550	2.0											92					
BC522E	A	S	N	625	150	20	20	50	10n	20	1200	2200	2.0											92					
BC523B	A	S	N	625	150	45	45	50	2n	45	180	400	2.0	100										92					
BC523C	A	S	N	625	150	45	45	50	2n	45	380	800	2.0	100										92					
BC526A	A	S	P	625	150	60	50	200	15n	30	60	800	2.0	100/200									10.0	5.0	92				
BC526B	A	S	P	625	150	60	50	200	15n	30	60	800	2.0	200/400									4.0	5.0	92				
BC526C	A	S	P	625	150	60	50	200	15n	30	60	800	2.0	300/600									4.0	5.0	92				
BC527	A	S	P	625	150	60	60	1000	100n	40	40	400	100	1.0										15	92				
BC528	A	S	P	625	150	80	80	1000	100n	60	40	400	100	1.0										15	92				
BC530	A	S	P	625	150	130	120	100	100	100	40	180	10	200									50	6	92				
BC531	A	S	P	625	150	160	150	100	50	120	60	240	10	200									50	6	92				
BC532	A	S	N	625	150	160	140	100	100	100	60	250	10	200									50	10	6	92			
BC533	A	S	N	625	150	180	160	100	50	120	40	250	10	200									50	8	6	92			
BC534	A	S	P	625	150	80	80	500	0.1	80	50		10										50			92			
BC535	A	S	N	625	150	80	80	500	0.1	80	50		10										50			92			
BC537	A	S	N	625	150	60	60	1000	0.1	40	40	400	100	1.0										15		92			
BC538	A	S	N	625	150	80	80	1000	10n	60	40	400	100	1.0										15		92			
BC727	A	S	P	625	150	50	40	1000	0.1	40	63	630	100	2.0										20		92			
BC728	A	S	N	625	150	30	25	1000	10n	25	63	630	100	2.0										20		92			
BC737	A	S	P	625	150	50	40	1000	0.1	40	63	630	100	2.0										20		92			
BC738	A	S	N	625	150	30	25	1000	10n	25	63	630	100	2.0										20		92			
BD115	A	S	N	875	200	245	180	150			22		50											100		5			
BD220	P	S	N	36W	150	80	7.0	4A			30	120	500										0.8			220			
BD221	P	S	N	36W	150	60	5.0	4A			30	120	1000										0.8			220			
BD222	P	S	N	36W	150	80	5.0	4A			20	80	1.5A										0.8			220			
BD223	P	S	P	36W	150	80	7.0	4A			30	120	500										0.8			220			
BD224	P	S	P	36W	150	60	5.0	4A			30	120	1000										0.8			220			
BD225	P	S	P	36W	150	80	5.0	4A			20	80	1.5A										0.8			220			
BF 167	A	S	N	150	175	40	30	25			30	60	4.0	6.0												18			
SE5040	A	S	N	175	175	30	30	25	50n	20	20	220	4.0	5.0										2.7		18			
BF 222	A	S	N	175	175	50	50		1000	10	20	60	2.0	4.0										2.0		18			
BF 257		S	N	1000	175	160	160	100	50n	100	25		30										75			5			
BF 258		S	N	1000	175	250	250	100	50n	200	25		30										75			5			
BF 259		S	N	1000	175	300	300	100	50n	250	25		30										75			5			
BF 336		S	N	1000	200	185	185	100			20		30										50			5			
BF 337		S	N	1000	200	250	250	100			20		30										50			5			
BF 338		S	N	1000	200	300	300	100			20		30										50			5			
BF X34	P	S	N	5W	200	120	60				40	150	2A	5.0											40		5		
BF X37	A	S	P	360	200	60	60	50			70	300	100	2.0										3.0	6.0		18		
BF X38	A	S	P	800	200	55	55	1000	50n	40	85		100	1.0												20	5		
BF X39	A	S	P	800	200	55	55	1000	50n	40	40		100	1.0												20	5		
BF X40	A	S	P	800	200	75	75	1000	50n	50	85		100	1.0												20	5		
BF X41	A	S	P	800	200	75	75	1000	50n	50	40		100	1.0												20	5		
BF Y50	AS	S	N	800	200	80	35	1000	50	60	20		10	10									60			5			
BF Y51	AS	S	N	800	200	60	30	1000	50	40	30		10	30									50			5			
BF Y52	AS	S	N	800	200	40	20	1000	50	30	30		10	30									50			5			
BF Y56	AS	S	N	800	200	80	45		50n	50	15		0.1	2.0											25		5		
BF Y64	AS	S	P	700	200	40	40				80		10	2.0											10		5		
BSX32	S	S	N	800	200	65	40	1000	4.0	50	60	150	100	3.0											10		5		
FQ3467		S	P	500	200		40		1.0	25	40		150	2.0													86	QUAD	
FQ3467		S	P	200	150		40		1.0	25	40		150	2.0													86	QUAD	
FQ3468		S	P	500	200		50		1.0	25	25		150	2.0													86	QUAD	
FQ3468		S	P	200	150		50		1.0	25	25		150	2.0													86	QUAD	
FQ3724		S	N	2W	150		40		1.7	40	50		100	2.0													116	QUAD	

TYPE	TOSHIBA	NEC	HITACHI	MITSUBISHI	MATSUSHITA	FUJITSU	SONY	SANYO	NOTE
BC522C	2SC364				2SC1478				
BC522D					2SC1478				
BC522E					2SC1478				
BC523B									
BC523C									
BC526A		2SA539	2SA672				2SA678		
BC526B		2SA539	2SA672				2SA678		
BC526C		2SA539	2SA672				2SA678		
BC527	2SA513								
BC528	2SA682								
BC530		2SA712							
BC531		2SA712							
BC532	2SC95	2SC49		2SC310					
BC533	2SC507	2SC1103							
BC534	2SA497	2SA606							
BC535	2SC512					2SC212			
BC537	2SC513								
BC538	2SC1382								
BC727	2SA486								
BC728						2SC354			
BC737	2SA48								
BC738						2SC354			
BD115	2SC1168	2SC1356						2SC1235	
BD220							2SC756		
BD221							2SC756		
BD222							2SC756		
BD223	2SB556						2SB518		
BD224	2SB556						2SB518		
BD225	2SB556						2SB518		
BF167			2SC167					2SC536	
SE5040			2SC167					2SC536	
BF222			2SC167					2SC536	
BF257				2SC818					
BF258	2SC996								
BF259	2SC996								
BF336	2SC996								
BF337	2SC996								
BF338	2SC996								
BFX34						2SD413			
BFX37					2SA722				
BF38	2SA516								
BFX39	2SA516								
BFX40	2SA516								
BFX41	2SA516								
BFY50						2SC229			
BFY51						2SC229			
BFY52						2SC229			
BFY56							2SC125		
BFY64		2SA552							
BSX32						2SC229			
FQ3467									
FPQ3467									
FQ3468									
FPQ3468									
FPQ3724									

FAIRCHILD

TYPE	USE	MATERIAL	POLARITY	MAXIMUM RATINGS				ELECTRICAL CHARACTERISTICS											OUTLINE TO.	NOTE						
				Pc 25°C (mW)	Tj (°C)	Vca (V)	Vcco (V)	Ic (mA)	Icso (μA)	hrc		Ihe	Iie (Ω)	Ire (×10)	hoe (μC)	fT ***fop (MHz)	NF (dB)	Cob (pF)			Coxtb (ps)					
FPQ3725		S	N	2W	150		50	10	1.7	40	50	100	2.0											116	QUAD	
FQ3724		S	N	500	200		40	10	1.7	40	50	100	2.0												86	QUAD
FQ3725		S	N	500	200		50	10	1.7	40	50	100	2.0												86	QUAD
MD918	A	S	N	300	200	30	15	50	0.1	15	50	.01						600	6.0	1.7					5	DUAL
MD2218	A	S	N	500	200	60	30	600			40	120	150					200		8.0					5	DUAL
MD2218A	A	S	N	500	200	75	40	600			40	120	150					250		8.0					5	DUAL
MD2219	A	S	N	500	200	30	60	600			100	300	150					250		8.0					5	DUAL
MD2219A	A	S	N	500	200	75	40	600			100	300	150					300		8.0					5	DUAL
MD2369	S	S	N	500	200	40	15	500	30n	20	40	140	10					500		4.0					5	DUAL
MD2904	S	S	P	500	200	60	40	600			40	120	150					200		8.0					5	DUAL
MD2904A	S	S	P	500	200	60	60	600			40	120	150					200		8.0					5	DUAL
MD2905	S	S	P	500	200	60	40	600			100	300	150					200		8.0					5	DUAL
MD2905A	S	S	P	500	200	60	60	600			100	300	150					200		8.0					5	DUAL
MD3250	A/S	S	P	500	200	50	40	50	10n	50	50	150	1.0	125	3.5	10	22	200	4.0	6.0					5	DUAL
MD3251	A/S	S	P	500	200	50	40	50	10n	50	100	300	1.0	250	7.0	20	35	250	3.0	6.0					5	DUAL
MPS2711	P	S	N	625	150	18	18	100	0.5	18	30	90	4.5	75						4.0						92
MPS2712	P	S	N	625	150	18	18	100	0.5	18	75	225	2.0	140						4.0						92
MPS2923	A	S	N	625	150	25	25	100	0.5	25				135						12						92
MPS2924	A	S	N	625	150	25	25	100	0.5	25				225						12						92
MPS2925	A	S	N	625	150	25	25	100	0.5	25				350						12						92
MPS2926	A	S	N	625	150	18	18	100	0.5	18				250						3.5						92
MPS3721	A	S	N	625	150	18	18	100	0.5	18				360						3.5						92
MPS3392	A	S	N	625	150	25	25	100	0.1	18	150	300	2.0	325						3.5						92
MPS3393	A	S	N	625	150	25	25	100	0.1	18	90	180	2.0	245						3.5						92
MPS3394	A	S	N	625	150	25	25	100	0.1	18	55	110	2.0	180						3.5						92
MPS3395	A	S	N	625	150	25	25	100	0.1	18	150	500	2.0	475						3.5						92
MPS3702	A	S	P	625	150	40	25	200	0.1	20	60	300	50				100			12						92
MPS3703	A	S	P	625	150	40	25	200	0.1	20	30	150	50				100			12						92
MPS3704	A	S	N	625	150	50	30	600	0.1	20	100	300	50				100			12						92
MPS3705	A	S	N	625	150	50	30	600	0.1	20	50	150	50				100			12						92
MPS3706	A	S	N	625	150	40	20	600	0.1	20	30	600	50				100			12						92
MPS3707	A	S	N	625	150	30	30	30	0.1	20	100	400	0.1	325				5.0								92
MPS3708	A	S	N	625	150	30	30	30	0.1	20	45	660	1.0	423												92
MPS3709	A	S	N	625	150	30	30	30	0.1	20	45	165	1.0	150												92
MPS3710	A	S	N	625	150	30	30	30	0.1	20	90	330	1.0	270												92
MPS3711	A	S	N	625	150	30	30	30	0.1	20	180	660	1.0	490												92
MPS5172	A	S	N	625	150	25	25	100	0.1	25	100	500	10	425												92
MPS6513	A	S	N	625	150	40	30	100	50n	30	50	100	2.0							3.5						92
MPS6513	A	S	N	625	150	40	30	100	50n	30	90	180	2.0							3.5						92
MPS6514	A	S	N	625	150	40	25	100	50n	30	150	300	2.0							3.5						92
MPS6515	A	S	N	625	150	40	25	100	50n	30	250	500	2.0							3.5						92
MPS6516	A	S	P	625	150	40	40	100	50n	30	50	100	2.0							4.0						92
MPS6517	A	S	P	625	150	40	40	100	50n	30	90	180	2.0							4.0						92
MPS6518	A	S	P	625	150	40	40	100	1.0	30	150	300	2.0							4.0						92
MPS6519	A	S	P	625	150	25	25	100	1.0	20	250	500	2.0							4.0						92
MPS6520	A	S	N	625	150	40	25	100	50n	30	200	400	2.0							3.0	3.5					92
MPS6521	A	S	N	625	150	40	25	100	50n	30	300	600	2.0							3.0	3.5					92
MPS6522	A	S	P	625	150	25	25	100	50n	20	200	400	2.0							3.0	3.5					92
MPS6523	A	S	P	625	150	25	25	100	50n	20	300	600	2.0							3.0	3.5					92
MPS6530	A	S	N	625	150	60	40	600	50n	40	40	120	100								5.0					92
MPS6531	A	S	N	625	150	60	40	600	50n	40	90	270	100								5.0					92
MPS6532	A	S	N	625	150	50	30	600	0.1	30	30		100								5.0					92
MPS6533M	A	S	P	625	150	40	40	600	50n	30	40	120	100							8.0						92
MP6534M	A	S	P	625	150	40	40	600	50n	30	90	270	100							8.0						92
MPS6535M	A	S	P	625	150	30	30	600	0.1	20	30		100							8.0						92

TYPE	TOSHIBA	NEC	HITACHI	mitsubishi	MATSUSHITA	FUJITSU	SONY	SANYO	NOTE
FRQ 3725									
FQ 3724									
FQ 3725									
MD918									DUAL
MD2218									DUAL
MD2218A									DUAL
MD2219									DUAL
MD2219A									DUAL
MD2369									DUAL
MD2904									DUAL
MD2904A									DUAL
MD2905									DUAL
MD2905A									DUAL
MD3250									DUAL
MD3251									DUAL
MPS 2711						2SC 826	2SC 805	2SC 427	
MPS 2712						2SC 826	2SC 805	2SC 427	
MPS 2923						2SC 826	2SC 805	2SC 427	
MPS 2924						2SC 826	2SC 805	2SC 427	
MPS 2925						2SC 826	2SC 805	2SC 427	
MPS 2926						2SC 826	2SC 805	2SC 427	
MPS 3721						2SC 826	2SC 805	2SC 427	
MPS 3392						2SC 826	2SC 805	2SC 427	
MPS 3393						2SC 826	2SC 805	2SC 427	
MPS 3394						2SC 826	2SC 805	2SC 427	
MPS 3395						2SC 826	2SC 805	2SC 427	
MPS 3702	2SA503		2SA537A			2SA523A			
MPS 3703	2SA503		2SA537A			2SA523A			
MPS 3704	2SC 503	2SC 959		2SC 307					
MPS 3705	2SC 503	2SC 959		2SC 307					
MPS 3706	2SC 482	2SC 959		2SC 307					
MPS 3707							2SC 470	2SC 1048	
MPS 3708							2SC 470	2SC 1048	
MPS 3709							2SC 470	2SC 1048	
MPS 3710							2SC 470	2SC 1048	
MPS 3711							2SC 470	2SC 1048	
MPS 5172	2SC 503					2SC 198			
MPS 6512	2SC 503					2SC 189			
MPS 6513	2SC 503					2SC 189			
MPS 6514	2SC 503					2SC 189			
MPS 6515	2SC 503					2SC 189			
MPS 6516	2SA501		2SA673						
MPS 6517	2SA501		2SA673						
MPS 6518	2SA501		2SA673						
MPS 6519	2SA501		2SA673						
MPS 6520				2SC 304				2SC 875	
MPS 6521				2SC 304				2SC 875	
MPS 6522	2SA501		2SA673						
MPS 6523	2SA501		2SA673						
MPS 6530	2SC 503	2SC 959							
MPS 6531	2SC 503	2SC 959							
MPS 6532	2SC 503	2SC 959							
MPS 6533M	2SA504					2SA580			
MPS 6534M	2SA504					2SA580			
MPS 6535M	2SA504		2SA673			2SA580			

FAIRCHILD

TYPE	USE	MATERIAL	POLARITY	MAXIMUM RATINGS							ELECTRICAL CHARACTERISTICS										OUTLINE TO.	NOTE
				Pc 25°C (mW)	Tj (°C)	Vca (V)	Vcbo (V)	Ic (mA)	Icso (µA)	Ic (mA)	Icso (µA)	Vce(V)	min.	max.	Ic(mA)	hfe	hfe (Ω)	hfe (×10)	hfe (µV)	fT *fice **fop (MHz)		
MPS6560	A	S	N	625	150	25	25	600	0.1	20	50	200	500					60		30		92
MPS6561	A	S	P	625	150	25	25	600	0.1	20	50	200	350					60		30		92
MPS6562	A	S	N	625	150	20	20	600	0.1	20	50	200	500					60		30		92
MPS6563	A	S	P	625	150	20	20	600	0.1	20	50	200	350					60		30		92
MPS6565	A	S	N	625	150	60	45	200	0.1	30	40	160	10	2.0						3.5		92
MPS6566	A	S	N	625	150	60	45	200	0.1	30	100	400	10	2.0						3.5		92
MPS6571	A	S	N	625	150	20	20	50	50n	20	250	1000	0.1					50		4.5		92
MPSA05	A	S	N	625	150	60	60	500	0.1	60	50		10					50				92
MPSA06	A	S	N	625	150	80	80	500	0.1	80	50		10					50				92
MPSA09	A	S	N	625	150	50	50	100	0.1	25	100	600	0.1					30			5.0	92
MPSA12	A	S	N	625	150				0.1	15	20K		10	35						8.0		92
MPSA13	A	S	N	625	150	30	30	300	0.1	30	5K		10				200	2.0	5.0			92
MPSA14	A	S	N	625	150	30	30	300	0.1	30	10K		10				200	2.0	5.0			92
MPSA20	A	S	N	625	150				40	100	0.1	30	40	400	5.0				125		4.0	92
MPSA70	A	S	P	625	150				40	100	0.1	30	40	400	5.0				125		4.0	92
MPSA42	A	S	N	625	150	300	300	500	0.1	200	40		30					50				92
MPSA43	A	S	N	625	150	200	200	500	0.1	160	50	200	30					50				92
MPSA55	A	S	P	625	150	60	60	500	0.1	60	50		10					50				92
MPSA56	A	S	P	625	150	80	80	500	0.1	80	50		10					50				92
MPSA92	A	S	P	625	150	330	300	500	0.25	200	25		30					50				92
MPSA93	A	S	P	625	150	200	200	500	0.25	160	30	150	30					50				92
MPSL01	A	S	N	625	150	140	120	600	1.0	75	50	300	10	30				60		8.0		92
MPSL51	A	S	P	625	150	100	100	600	1.0	50	40	250	50	20				60		8.0		92
MPSL07		S	P	625	150	6.0	6.0	80				30	120	10				500		3.0		92
MPSL08		S	P	625	150	12	12	80				30	120	10				700		3.0		92
PE3100		S	N	425	150	30	30		0.2	30	30	225	5	5								92
PE5010	A	S	N	300	150	30	30		50n	10	25	200	4	3.75				3.3				92
PE5013	A	S	N	300	150	20	20		50n	10	20	200	4	3.0				4.0				92
PE5015	A	S	N	300	150	20	20		50n	10	20	200	4	3.0				4.0				92
PE5025	IF	S	N	425	150	30	30		50n	30	20	100	10	5.0								92
PE5029	A	S	N	425	150	35	30		0.2	30	30	225	5	5.0					6.0			92
PE5030	A	S	N	425	150	45	40		0.1	30	45	150	7	6.0								92
PE5031	A	S	N	425	150	40	30		0.1	30	30	180	5	6.0					4.5			92
PE6020	A	S	N	625	150	60	60	IA	0.1	50	100	300	150	4.0								92
PE6021	A	S	N	625	150	60	60	IA	0.1	50	100	300	150	4.0								92
PN4357	A	S	P	625	150	240	240		20n	200	80	300	10	250					10	7.0		92
PN5964	AP	S	N	625	150	160	150	600	50n	120	50	250	10	50	6K		40					92
PN5965	AP	S	N	625	150	200	180	600	50n	160	50	250	10	50	6K		40					92
SE5020	A	S	N	175	175	20	20		50n	10	20	200	4	6				3.3				18
SE5021	A	S	N	175	175	20	20		50n	10	20	200	4	6				4.0				18
SE5022	A	S	N	175	175	20	20		50n	10	20	200	4	6				4.0				18
SE5023	A	S	N	175	175	20	20		50n	10	20	200	4	6				6.0				18
SE5024	A	S	N	175	175	20	20		50n	10	20	200	4	6				6.0				18
SE5035	A	S	N	200	175				50n	30	40	180	5	10				5.0				18
SE5036	A	S	N	200	175				50n	30	30	225	5	8				5.0				18
SE5050	A	S	N	175	175	20	20		50n	10				3				4.0				18
SE5051	A	S	N	175	175	20	20		50n	10				3				4.0				18
SE5055	A	S	N	175	175	20	20		50n	20	20	220	2	5				5.0				18
SE6020	A	S	N	300	125	60	60	IA	0.1	50	100	300	150	4								5
SE6021	A	S	N	300	125	60	60	IA	0.1	50	100	300	150	4								5
SE7055	P	S	N	1000	200	220	220		0.1	150	20		1	2				80				5
SE7056	P	S	N	1000	200	300	300		0.1	200	20		1	2				80				5
SE7057	P	S	N	1000	200	450	450		0.1	300	15		1	1.5				80				5
SE9331	P	S	N	20W	175	300	300	IA	10	300	30	250	100					10		20		66
2N706		S	N	300	175	25			0.3	15	20		10	2.0						6		18

TYPE	TOSHIBA	NEC	HITACHI	MITSUBISHI	MATSUSHITA	FUJITSU	SONY	SANYO	NOTE
MPS6560		2SC959		2SC306		2SC221			
MPS6561	2SA504					2SA580			
MPS6562		2SC959		2SC306		2SC221			
MPS6563	2SA504					2SA580			
MPS6565	2SC501					2SC202			
MPS6566	2SC501					2SC202			
MPS6571	2SC482						2SC15		
MPSA05	2SC503								
MPSA06	2SC560					2SC560			
MPSA09						2SC969			
MPSA12									
MPSA13									
MPSA14									
MPSA20			2SC151					2SC875	
MPSA70	2SA501		2SA673						
MPSA42									
MPSA43									
MPSA55								2SA535	
MPSA56			2SA537A						
MPSA92									
MPSA93									
MPSL01		2SA712							
MPSL51		2SA712							
MPSL07			2SA742						
MPSL08			2SA742						
PE3100						2SC200			
PE5010						2SC238			
PE50B						2SC238			
PE5015						2SC238			
PE5025	2SC383	2SC149				2SC61			
PE5029	2SC383	2SC49				2SC46			
PE5030	2SC383	2SC49				2SC46			
PE5031	2SC383	2SC49				2SC46			
PE6020						2SC1069			
PE6021						2SC1069			
PN4357									
PN5964					2SD198				
PN5965					2SD198				
SE5020									
SE5021									
SE5022									
SE5023									
SB5024									
SE5035									
SE5036									
SE5050		2SC567							
SE5051		2SC567							
SE5055		2SC567							
SE6020						2SC1069			
SE6021						2SC1069			
SE7055									
SE7056									
SE7057									
SE9331							2SD326		
2N706		2SC1072	2SC1072			2SC1072			

FAIRCHILD

TYPE	USE	MATERIAL	POLARITY	MAXIMUM RATINGS						ELECTRICAL CHARACTERISTICS										OUTLINE TO.	NOTE								
				Pc 25°C (mW)	Tj (°C)	Vcs (V)	Vcso (V)	Ic (mA)	Icso (μA)	hFE		hfe	h _{ie} (Ω)	h _{re} (×10)	hoe (μS)	f _T *Icso **Ic (MHz)	NF (dB)	Cob (pF)	Coverly (ps)										
MPS706	SH	S	N	625	150	25			0.5	15	20		10	2.0										92					
2N706A	SH	S	N	300	175	25			0.5	15	20	60	10	2.0											18				
MPS706A	SH	S	N	625	150	25			0.5	15	20	60	10	2.0											92				
2N709	SH	S	N	300	200	15	6.0		50n	5	20	120	10					600							18				
FT709	SH	S	N	300	200	15	6.0		50n	5	30	125	10					600							18				
2N3010	SH	S	N	300	200	15	6.0					25	125	10					600							18			
2N718A	A	S	N	500	200	75	32		10n	60	40	120	150	3.0						12	25					18			
2N1613	A	S	N	800	150	75	32		10n	60	40	120	150	3.0						12	25					5			
PN1613	A	S	N	625	200	75	32		10n	60	40	120	150	3.0						12	25					92			
2N956	A	S	N	500	200	75	32		10n	60	100	300	150	3.5						8	25					18			
2N1711	A	S	N	800	200	75	32		10n	60	100	300	150	3.5						8	25					5			
PN1711	A	S	N	625	150	75	32		10n	60	100	300	150	3.5						8	25					92			
2N834	SH	S	N	300	175	40		200	0.5	20	25		10					350								18			
MPS834	SH	S	N	625	150	40		200	0.5	20	25		10					350								92			
2N918	A	S	N	200	200	30	15	50	10n	15	20		3	6						6	1.7					18			
MPS918	A	S	N	625	150	30	15	50	10n	15	20		3	6						6	1.7					92			
2N930	A	S	N	300	175	45	45	30	10n	45	100	300	0.01	400						3	8.0					18			
2N997	A	S	N	500	175	75	45	300	10n	60	1000			0.1												18			
2N998	A	S	N	500	200	100	60		10n	90	800			1.0	1000					6	30					18			
2N999	A	S	N	500	200	60	60	500	10n	60	1000			0.1												20	18		
2N1893	A	S	N	800	200	120	80		10n	90	20		0.1	70							15						5		
PN1893	A	S	N	625	150	120	80		10n	90	20		0.1	70							15						92		
2N2218	A	S	N	800	175	60	30	800	10n	50	40	120	150							60							5		
2N2219	A	S	N	800	175	60	30	800	10n	50	100	300	150							60							5		
PN2218	A	S	N	625	150	60	30	800	10n	50	40	120	150							60							92		
PN2219	A	S	N	625	150	60	30	800	10n	50	100	300	150							60							92		
2N2221	A	S	N	500	175	60	30	800	10n	50	40	120	150							60							18		
2N2222	A	S	N	500	175	60	30	800	10n	50	100	300	150							60							18		
PN2221	A	S	N	625	150	60	30	800	10n	50	40	120	150							60							92		
PN2222	A	S	N	625	150	60	30	800	10n	50	100	300	150							60							92		
2N2218A	A	S	N	800	175	75	40	800	10n	60	40	120	150	150	60	500					8						5		
2N2219A	A	S	N	800	175	75	40	800	10n	60	100	300	150	200	60	800					4	8					5		
PN2218A	A	S	N	625	150	75	40	800	10n	60	40	120	150	150	60	500					8						92		
PN2219A	A	S	N	625	150	75	40	800	10n	60	100	300	150	200	60	800					4	8					92		
2N2221A	A	S	N	500	175	75	40	800	10n	60	40	120	150	150	60	500					8						18		
2N2222A	A	S	N	500	175	75	40	800	10n	60	100	300	150	200	60	800					4	8					18		
PN2221A	A	S	N	625	150	75	40	800	10n	60	40	120	150	150	60	500					8						92		
PN2222A	A	S	N	625	150	75	40	800	10n	60	100	300	150	200	60	800					4	8					92		
2N2369	SH	S	N	360	200	40	15	500	0.4	20	40	120	10														4	18	
2N2369A	SH	S	N	360	200	40	15	500	0.4	20	40	120	10														4	18	
MPS2369	SH	S	N	625	150	40	15	500	0.4	20	40	120	10														4	92	
2N2484	A	S	N	360	200	60	60	50	10n	45	100	500	.01	500							3	6					18		
PN2484	A	S	N	625	150	60	60	50	10n	45	250	500	.01	700							3	4.5					92		
2N2639	A	S	N	600		45	45	30	10n	45	50	300	.01	350							8	4					5		
2N2640	A	S	N	600		45	45	30	10n	45	50	300	.01	350							8	4					5		
2N2641	A	S	N	600		45	45	30	10n	45	50	300	.01	350							8	4					5		
2N2642	A	S	N	600		45	45	30	10n	45	100	300	.01	350							8	4					5		
2N2643	A	S	N	600		45	45	30	10n	45	100	300	.01	350							8	4					5		
2N2644	A	S	N	600		45	45	30	10n	45	100	300	.01	350							8	4					5		
2N2723	A	S	N	500	200	80	60	40	10n	60	2K	10K	10	9K							10	10					18		
2N2724	A	S	N	500	200	80	60	40	10n	60	7K	50K	10	30K								6	10				18		
2N2725	A	S	N	500	200	45	45	30	2n	30	2K	10K	0.1	9K													18		
2N2894	SH	S	P	360	200	12	12	200	10	6	40	150	30									6					18		
2N2894A	SH	S	P	360	200	12	12	200	10	10	40	120	30										4.5				18		
2N3012	SH	S	P	360	200	12	12	200			30	120	30										6				18		

TYPE	TOSHIBA	NEC	HITACHI	mitsubishi	MATSUSHITA	FUJITSU	SONY	SANYO	NOTE
MPS 706	2SC503					2SC906			
2N706A	2SC982								
MPS 706A	2SC503					2SC906			
2N709						2SC850	2SC634		
FT 709						2SC850	2SC634		
2N3010						2SC850	2SC634		
2N718A		2SC1008					2SC1124		
2N1613		2SC1008					2SC1124		
PN1613		2SC1008					2SC1124		
2N956		2SC1008					2SC1124		
2N1711		2SC1008					2SC1124		
PN1711		2SC1008					2SC1124		
2N834	2SC503					2SC189			
MPS 834	2SC503					2SC189			
2N918						2SC172A			
MPS 918						2SC238			
2N930		2SC899							
2N997									
2N998									
2N999									
2N1893							2SC1127		
PN1893							2SC1127		
2N2218					2SC696	2SC229			
2N2219					2SC696	2SC229			
PN2218					2SC696	2SC229			
PN2219					2SC696	2SC229			
2N2221					2SC696	2SC229			
2N2222					2SC696	2SC229			
PN2221					2SC696	2SC229			
PN2222					2SC696	2SC229			
2N2218A					2SC696	2SC229			
2N2219A					2SC696	2SC229			
PN2218A					2SC696	2SC229			
PN2219A					2SC696	2SC229			
2N2221A					2SC696	2SC229			
2N2222A					2SC696	2SC229			
PN2221A					2SC696	2SC229			
PN2222A					2SC696	2SC229			
2N2369	2SC108					2SC233			
2N2369						2SC233			
MPS 2369	2SC108					2SC233			
2N2484		2SC1400						2SC1570	
PN2484		2SC1400						2SC1570	
2N2639				2SC1583					
2N2640				2SC1583					
2N2641				2SC1583					
2N2642				2SC1583					
2N2643				2SC1583					
2N2644				2SC1583					
2N2723									
2N2724									
2N2725									
2N2894	2SA467					2SA559			
2N2894A	2SA467					2SA559			
2N3012	2SA467					2SA559			

FAIRCHILD

TYPE	USE	MATERIAL	POLARITY	MAXIMUM RATINGS					ELECTRICAL CHARACTERISTICS										OUTLINE TO.	NOTE		
				Pc 25°C (mW)	Tj (°C)	Vce (V)	Vceo (V)	Ic (mA)	Icbo (μA)	Vce(V)	hrc		hfe	hie (Ω)	hre (×10)	hfe (μS)	ft *fmax **fβ (MHz)	NF (dB)			Cob (pF)	Coxbb (ps)
2N3209	SH	S	P	360	200	20	20	200			30	120	30							5	18	
2N2904	A/S	S	P	600	200	60	40	600	20n	50	30	120	150							8	5	
2N2905	A/S	S	P	600	200	60	40	600	20n	50	140	300	150							8	5	
2N2906	A/S	S	P	400	200	60	40	600	20n	50	00	120	150							8	18	
2N2907	A/S	S	P	400	200	60	40	600	20n	50	140	300	150							8	18	
PN2904	A/S	S	P	625	150	60	40	600	20n	50	00	120	150							8	92	
PN2905	A/S	S	P	625	150	60	40	800	20n	50	140	300	150							8	92	
PN2906	A/S	S	P	625	150	60	40	800	20n	50	00	120	150							8	92	
PN2907	A/S	S	P	625	150	60	40	600	20n	50	140	300	150							8	92	
2N2904A	A/S	S	P	600	200	60	60	600	10n	50	00	120	150							8	5	
2N2905A	A/S	S	P	600	200	60	60	600	10n	50	140	300	150							8	5	
2N2906A	A/S	S	P	400	200	60	60	600	10n	50	00	120	150							8	18	
2N2907A	A/S	S	P	400	200	60	60	600	10n	50	140	300	150							8	18	
PN2904A	A/S	S	P	625	150	60	60	600	10n	50	00	120	150							8	92	
PN2905A	A/S	S	P	625	150	60	60	600	10n	50	140	300	150							8	92	
PN2906A	A/S	S	P	625	150	60	60	600	10n	50	00	120	150							8	92	
PN2907A	A/S	S	P	625	150	60	60	600	10n	50	140	300	150							8	92	
2N2913	A	S	N	500	200	45	45	30	10n	45	00	240	.01					4	6	5		
2N2914	A	S	N	500	200	45	45	30	10n	45	160	600	.01					3	6	5		
2N2972	A	S	N	300	200	45	45	30	10n	45	50	240	.01					4	6	18		
2N2973	A	S	N	300	200	45	45	30	10n	45	160	600	.01					3	6	18		
2N2915	A	S	N	500	200	45	45	30	10n	45	50	240	.01					4	6	5		
2N2915A	A	S	N	500	200	45	45	30	10n	45	60	240	.01					4	6	5		
2N2919	A	S	N	500	200	60	60	30	2n	45	60	240	.01					4	6	5		
2N2919A	A	S	N	500	200	60	60	30	2n	45	60	240	.01					4	6	5		
2N2974	A	S	N	300	200	45	45	30	10n	45	60	240	.01					4	6	18		
2N2978	A	S	N	300	200	60	60	30	2n	45	60	240	.01					4	6	18		
2N2916	A	S	N	500	200	45	45	30	10n	45	160	600	.01					3	6	5		
2N2916A	A	S	N	500	200	45	45	30	10n	45	150	600	.01					3	6	5		
2N2920	A	S	N	500	200	60	60	30	2n	45	150	600	.01					3	6	5		
2N2920A	A	S	N	500	200	60	60	30	2n	45	150	600	.01					3	6	5		
2N2975	A	S	N	300	200	45	45	30	10n	45	150	600	.01					3	6	18		
2N2979	A	S	N	300	200	60	60	30	2n	45	150	600	.01					3	6	18		
2N2917	A	S	N	500	200	45	45	30	10n	45	50	240	.01					4	6	5		
2N2918	A	S	N	500	200	45	45	30	10n	45	160	600	.01					3	6	5		
2N2976	A	S	N	300	200	45	45	30	10n	45	50	240	.01					4	6	18		
2N2977	A	S	N	300	200	45	45	30	10n	45	160	600	.01					3	6	18		
2N3009	S	S	N	360	200	40	15	200			50	120	30						5	18		
2N3013	S	S	N	360	200	40	15	200			30	120	30						5	18		
2N3014	S	S	N	360	200	40	20	200			30	120	30						5	18		
2N3011	S	S	N	360	200	30	12	200			30	120	10						4	18		
2N3019	A	S	N	800	200	140	80	1A	10n	90	100	300	150	120				4	12	5		
2N3020	A	S	N	800	200	140	80	1A	10n	90	40	120	150	240					12	5		
2N3053	A	S	N		200	60	40	700			50	250	150						15	5		
2N3054	P	S	N	25W	200	90	55	4A			25	100	500	100						66		
2N3055	P	S	N	115W	200	100	60	15A			20	70	4A	80						3		
2N3107	A/S	S	N	800	200	100	60		10	60	00	300	150					7	20	5		
2N3108	A/S	S	N	800	200	100	60		10	60	140	120	150					7	25	5		
2N3109	A/S	S	N	800	200	80	40		10	60	00	300	150					7	20	5		
2N3110	A/S	S	N	800	200	80	40		10	60	40	120	150					7	25	5		
2N3117	A	S	N	360	200	60	60	50	10n	45	250	500	01						4.5	18		
2N3137	A	S	N	600	200	40	20	150	50n	20	20	120	50						3.5	5		
2N3250	A/S	S	P	300	200	50	40	200			50	150	10					250	6	6	18	
PN3250	A/S	S	P	625	150	50	40	200			50	150	10					250	6	6	92	
2N3250A	A/S	S	P	300	200	60	60	200			50	150	10					250	6	6	18	

TYPE	TOSHIBA	NEC	HITACHI	MITSUBISHI	MATSUSHITA	FUJITSU	SONY	SANYO	NOTE
2N3209						2SA559			
2N2904	2SA512	2SA571			2SA546				
2N2905	2SA512	2SA571			2SA546				
2N2906	2SA512	2SA571			2SA546				
2N2907	2SA512	2SA571			2SA546				
PN2904	2SA512	2SA571			2SA546				
PN2905	2SA512	2SA571			2SA546				
PN2906	2SA512	2SA571			2SA546				
PN2907	2SA512	2SA571			2SA546				
2N2904A	2SA512	2SA571			2SA546				
2N2905A	2SA512	2SA571			2SA546				
2N2906A	2SA512	2SA571			2SA546				
2N2907A	2SA512	2SA571			2SA546				
PN2904A	2SA512	2SA571			2SA546				
PN2905A	2SA512	2SA571			2SA546				
PN2906A	2SA512	2SA571			2SA546				
PN2907A	2SA512	2SA571			2SA546				
2N2913				2SC1583					
2N2914				2SC1583					
2N2972				2SC1583					
2N2973				2SC1583					
2N2915				2SC1583					
2N2915A				2SC1583					
2N2919				2SC1583					
2N2919A				2SC1583					
2N2974				2SC1583					
2N2978				2SC1583					
2N2916				2SC1583					
2N2916A				2SC1583					
2N2920				2SC1583					
2N2920A				2SC1583					
2N2975				2SC1583					
2N2979				2SC1583					
2N2917				2SC1583					
2N2918				2SC1583					
2N2976				2SC1583					
2N2977				2SC1583					
2N3009			2SC479			2SC233			
2N3013			2SC479			2SC233			
2N3014			2SC479			2SC233			
2N3011			2SC1385			2SC233			
2N3019			2SC936				2SC867		
2N3020			2SC936				2SC867		
2N3053				2SC775					
2N3054		2SD188					2SD88		
2N3055		2SD181							
2N3107	2SC485	2SD328							
2N3108	2SC485	2SD328							
2N3109	2SC485	2SD328							
2N3110	2SC485	2SD328							
2N3117		2SC1400							
2N3137				2SC304					
2N3250		2SA718					2SA678		
PN3250		2SA718					2SA678		
2N3250A		2SA718					2SA678		

FAIRCHILD

TYPE	USE	MATERIAL	POLARITY	MAXIMUM RATINGS				ELECTRICAL CHARACTERISTICS													OUTLINE TO.	NOTE		
				Pc 25°C (mW)	Tj (°C)	Vce (V)	Vcbo (V)	Ic (mA)	Icso (μA)		hfe		hfe	hie (Ω)	hre (×10)	hoe (μΩ)	f _T *Icso *Ic (MHz)	NF (dB)	Cob (pF)	Coxbr (ps)				
2N3251	A/S	S	P	360	200	50	40	200			100	300	10					250	6	6		18		
PN3251	A/S	S	P	625	150	50	40	200			100	300	10					250	6	6		92		
2N3251A	A/S	S	P	360	200	60	60	200			100	300	10					250	6	6		18		
PN3251A	A/S	S	P	625	150	60	60	200			100	300	10					250	6	6		92		
2N3409	A	S	N		230	60	30	500	10n	50									4	8		5		
2N3410	A	S	N		230	60	30	500	10n	50									4	8		5		
2N3411	A	S	N		230	60	30	500	10n	50									4	8		5		
2N3423	A	S	N	450	200	30	15	50	10n	15	20	200	3					600	3.5	1.7		5		
2N3224	A	S	N	450	200	30	15	50	10n	15	20	200	3					600	3.5	1.7		5		
2N3439	P	S	N	1W		450	350	500		20	360	40	160	20						10		5		
2N3440	P	S	N	1W		300	250	500	20	250	40	160	20							10		5		
2N3467	S	S	P	5W	200	40	40	1A.	0.1	30	40	120	500							25		5		
2N3468	S	S	P	5W	200	50	50	1A	0.1	30	25	75	500							25		5		
2N3563	A	S	N	200	125	30	12	50	50n	15	20	200	8	180						1.7		18		
MPS3563	A	S	N	625	150	30	12	50	50n	15	20	200	8	180						1.7		92		
2N3564	A	S	N	200	125	30	15	100	50n	15	20	200	15									18		
2N3565	A	S	N	200	125	30	25	50	50n	25	150	600	1	450						4		18		
PN3565	A	S	N	625	150	30	25	50	50n	25	150	600	1	450						4		92		
2N3566	A	S	N	300	125	40	30	200	50n	20	150	600	10							25		5		
PN3566	A	S	N	625	150	40	30	200	50n	20	150	600	10							25		92		
2N3567	A	S	N	300	125	80	40	100	50n	40	40	120	150	16								5		
PN3567	A	S	N	625	150	80	40	100	50n	40	40	120	150	16								92		
2N3568	A	S	N	300	125	80	60	100	50n	40	40	120	150	16								5		
PN3568	A	S	N	625	150	80	60	100	50n	40	40	120	150	16								92		
2N3569	A	S	N	300	125	80	40	100	50n	40	100	300	150	16								5		
PN3569	A	S	N	625	150	80	40	100	50n	40	100	300	150	16								92		
2N3638	A/S	S	P	700	125	25	25	500			20		10	25	2000	2600	1200			20		5		
2N3638A	A/S	S	P	700	125	25	25	500			100		10	100	2000		1200			20		5		
MPS3638	A/S	S	P	1W	150	25	25	500			20		10	100	1500	2600	1200			10		92		
MPS3638A	A/S	S	P	1W	150	25	25	500			100		10	100	2000	1500	1200			10		92		
2N3639	SH	S	P	200	125	6	6	80			30	120	10							3.5		18		
MPS3639	SH	S	P	625	150	6	6	80			30	120	10							3.5		92		
2N3640	SH	S	P	200	125	12	12	80			30	120	10							3.5		18		
MPS3640	S	S	P	625	150	12	12	80			30	120	10							3.5		92		
2N3641	A	S	N	350	125	60	30	500			40	120	150							8		5		
PN3641	A	S	N	625	150	60	45	500			40	120	150							8		92		
2N3642	A	S	N	350	125	60	30	500			40	120	150							8		5		
PN3642	A	S	N	625	150	60	45	500			40	120	150							8		92		
2N3643	A	S	N	350	125	60	30	500			100	300	150							8		5		
PN3643	A	S	N	625	150	60	45	500			100	300	150							8		92		
2N3644	A/S	S	P	300	125	60	60	500			80	240	50							8		5		
PN3644	A/S	S	P	625	150	45	45	500			80	240	50							8		92		
2N3645	A/S	S	P	300	125	60	60	500			80	240	50							8		5		
PN3645	A/S	S	P	625	150	45	45	500			80	240	50							8		92		
2N3646	S	S	N	200	125	40	15	200			30	120	30							5		18		
MPS3646	S	S	N	625	150	40	15	200			30	120	30							5		92		
2N3688	A	S	N	200	125	40	40		50n	20	30		4						5.5	1.6		18		
PN3688	A	S	N	625	150	40	40		50n	20	30		4						5.5	1.6		92		
2N3689	A	S	N	200	125	40	40		50n	20	30		4						5.5	1.6		18		
PN3689	A	S	N	625	150	40	40		50n	20	30		4						5.5	1.6		92		
2N3690	A	S	N	200	125	40	40		50n	20	30		4						5.5	1.6		18		
PN3690	A	S	N	625	150	40	40		50n	20	30		4						5.5	1.6		92		
SE5006	A	S	N						50n	20	30		4								1.6		18	
2N3693	A	S	N	200	125	45	45	30	50n	30	40	160	10						4	6		18		
MPS3693	A	S	N	625	150	45	45	30	50n	35	40	160	10						4	3.5		92		

TYPE	TOSHIBA	NEC	HITACHI	MITSUBISHI	MATSUSHITA	FUJITSU	SONY	SANYO	NOTE
2N3251		2SA718					2SA678		
PN3251		2SA718					2SA678		
2N3251A		2SA718					2SA678		
PN3251A		2SA718					2SA678		
2N3409									DUAL
2N3410									DUAL
2N3411									DUAL
2N3423									DUAL
2N3424									DUAL
2N3439									
2N3440									
2N3467						2SB456			
2N3468						2SB456			
2N3563									
MPS3563									
2N3564						2SC54			
2N3565	2SC560					2SC560			
PN3565	2SC560					2SC560			
2N3566	2SC560					2SC560			
PN3566	2SC560					2SC560			
2N3567	2SC560					2SC560			
PN3567	2SC560					2SC560			
2N3568	2SC560					2SC560			
PN3568	2SC560					2SC560			
2N3569	2SC560					2SC560			
PN3569	2SC560					2SC560			
2N3638	2SA682	2SA717							
2N3638A	2SA682	2SA717							
MPS3638	2SA682	2SA717							
MPS3638A	2SA682	2SA717							
2N3639		2SA552						2SA532	
MPS3639		2SA552						2SA532	
2N3640		2SA552						2SA532	
MPS3640		2SA552						2SA532	
2N3641	2SC503					2SC189			
PN3641	2SC503					2SC189			
2N3642	2SC503					2SC189			
PN3642	2SC503					2SC189			
2N3643	2SC503					2SC189			
PN3643	2SC503					2SC189			
2N3644		2SA712						2SA532	
PN3644		2SA712						2SA532	
2N3645		2SA712						2SA532	
PN3645		2SA712						2SA532	
2N3646				2SC307		2SC216			
MPS3646				2SC307		2SC216			
2N3688	2SC594	2SC594		2SC594		2SC238			
PN3688	2SC594	2SC594		2SC594		2SC238			
2N3689	2SC594	2SC594		2SC594		2SC238			
PN3689	2SC594	2SC594		2SC594		2SC238			
2N3690	2SC594	2SC594		2SC594		2SC238			
PN3690	2SC594	2SC594		2SC594		2SC238			
SE5006	2SC594	2SC594		2SC594		2SC238			
2N3693				2SC305		2SC247			
MPS3693				2SC305		2SC247			

FAIRCHILD

TYPE	USE	MATERIAL	POLARITY	MAXIMUM RATINGS					ELECTRICAL CHARACTERISTICS												OUTLINE TO.	NOTE								
				Pc	Tj	Vca	Vco	Ic	Icbo		hre		hfe	hfe	hfe	hoe	f _t	NF	Cob	Cox										
				(mW)	(°C)	(V)	(V)	(mA)	(μA)	Va(V)	min.	max.	Ic(mA)	(Ω)	(X10)	(μΩ)	(MHz)	(dB)	(pF)	(pS)										
2N3694	A	S	N	200	125	45	45	30	50n	30	100	400	10											4	6		18			
MPS3694	A	S	N	625	150	45	45	30	50n	35	100	400	10											4	3.5		92			
2N3700	A	S	N	500	200	140	80	1A	10n	90	100	300	150	240									4	12		18				
2N3701	A	S	N	500	200	140	80	1A	10n	90	40	120	150	120												12		18		
2N3713	P	S	N	150W		80	60	10A			25	75	1A	140												250		3		
2N3714	P	S	N	150W		100	80	10A			25	75	1A	140												250		3		
2N3715	P	S	N	150W		80	60	10A			50	150	1A	140												250		3		
2N3716	P	S	N	150W		100	80	10A			50	150	1A	140												250		3		
2N3722	S	S	N	800	200	80	60	1A			40	150	100													10		5		
FT3723	S	S	N	800	200	100	70	1A			40	150	100													9		5		
2N3724	SH	S	N	800	200	50	30	1A	1.7	40	60	150	100													12		5		
2N3725	SH	S	N	800	200	80	50	1A	1.7	60	60	150	100													10		5		
2N3726	A	S	P	500	200	60	60	300	10n	30	135	350	1	230	11.5	1.5	80							4	8		5		5	
2N3727	A	S	P	500	200	60	60	300	10n	30	135	350	1	230	11.5	1.5	80							4	8		5		5	
2N3728	A	S	N	550	200	60	30	500	10n	50	45	180	1		3.5	300	20								7	8		5		5
2N3729	A	S	N	550	200	60	30	500	10n	50	45	180	1		3.5	300	20								7	8		5		5
2N3740	P	S	P	25W	200	60	60	1A	0.1	60	30	100	250	25												100		66		66
2N3741	P	S	P	25W	200	80	80	1A	0.1	80	30	100	250	25												100		66		66
2N3766	P	S	N	20W		80	60	4A	0.1	80	40	160	500	40												30		66		66
2N3767	P	S	N	20W		100	80	4A	0.1	100	40	160	500	40												30		66		66
2N3789	P	S	P	150W		60	60	10A			25	90	1A	140												500		3		3
2N3790	P	S	P	150W		80	80	10A			25	90	1A	140												500		3		3
2N3791	P	S	P	150W		60	60	10A			50	180	1A	140												500		3		3
2N3792	P	S	P	150W		80	80	10A			50	180	1A	140												500		3		3
2N3800	A	S	P	360	200	60	60	50	10n	50	150	450	1	380	30	25	60								3	4		18		18
2N3801	A	S	P	360	200	60	60	50	10n	50	300	900	1	600	40	25	60								1.5	4		5		5
2N3802	A	S	P	360	200	60	60	50	10n	50	150	450	1	380	30	25	60								3	4		18		18
2N3803	A	S	P	360	200	60	60	50	10n	50	300	900	1	600	40	25	60								1.5	4		18		18
2N3806	A	S	P	600	200	60	60	50	10n	50	150	450	1	380	30	25	60								3	4		5		5
2N3807	A	S	P	600	200	60	60	50	10n	50	300	900	1	600	40	25	60								1.5	4		5		5
2N3808	A	S	P	600	200	60	60	50	10n	50	150	450	1	380	30	25	60								3	4		5		5
2N3809	A	S	P	600	200	60	60	50	10n	50	300	900	1	600	40	25	60								1.5	4		5		5
2N3804	A	S	P	360	200	60	60	50	10n	50	150	450	1	380	30	25	60								3	4		18		18
2N3804A	A	S	P	360	200	60	60	50	10n	50	150	450	1	380	30	25	60								3	4		18		18
2N3805	A	S	P	360	200	60	60	50	10n	50	300	900	1	600	40	25	60								1.5	4		18		18
2N3805A	A	S	P	360	200	60	60	50	10n	50	300	900	1	600	40	25	60								1.5	4		18		18
2N3810	A	S	P	600	200	60	60	50	10n	50	150	450	1	380	30	25	60								3	4		5		5
2N3810A	A	S	P	600	200	60	60	50	10n	50	150	450	1	380	30	25	60								3	4		5		5
2N3811	A	S	P	600	200	60	60	50	10n	50	300	900	1	600	40	25	60								1.5	4		5		5
2N3811A	A	S	P	600	200	60	60	50	10n	50	300	900	1	600	40	25	60								1.5	4		5		5
2N3903	A/S	S	N	625	150	60	40	200			50	150	10	125	8	5	40	250							6	4		92		92
2N3904	A/S	S	N	625	150	60	40	200			100	300	10	250	10	8	40	300							5	4		92		92
2N3905	A/S	S	P	625	150	40	40	200			50	150	10	125	8	5	40	200							5	4.5		92		92
2N3906	A/S	S	P	625	150	40	40	200			100	300	10	250	12	10	60	250							4	4.5		92		92
2N3923	A	S	N	800	200	150	150	100	10n	100	30	120	25	20				40								3.5		5		5
2N3946	A/S	S	N	360	200	60	40	200			50	100	10	150	6	10	30								5	4		18		18
2N3947	A/S	S	N	360	200	60	40	200			100	300	10	400	12	20	50								5	4		18		18
2N3962	A	S	P	360	200	60	60	200			100	450	1	330	17	10	40								4	6		18		18
2N3964	A	S	P	360	200	45	45	200			250	600	1	470	20	10	50								4	6		18		18
2N3965	A	S	P	360	200	60	60	200			250	600	1	470	20	10	50								4	6		18		18
2N4013	SH	S	N	360	200	50	30	500	1.7	40	60	150	100													12		18		18
2N4014	SH	S	N	360	200	80	50	500	1.7	60	60	150	100													10		18		18
2N4015	A	S	P	500	200	60	60	300	10n	50	135	350	1	260	11.5	1.5	80								4	8		5		5
2N4016	A	S	P	500	200	60	60	300	10n	50	135	350	1	260	11.5	1.5	80								4	8		5		5
2N4017	A	S	P	600	200	80	80	200	10n	70	100	500	1	330	17	10	40								10	6		5		5

TYPE	TOSHIBA	NEC	HITACHI	mitsubishi	MATSUSHITA	FUJITSU	SONY	SANYO	NOTE
2N3694				2SC305		2SC247			
MPS3694				2SC305		2SC247			
2N3700									
2N3701									
2N3713	2SD113					2SD54			
2N3714	2SD113					2SD54			
2N3715	2SD113					2SD54			
2N3716	2SD113					2SD54			
2N3722		2SD78					2SC756		
FT3723		2SD78					2SC756		
2N3724		2SD78						2SD330	
2N3725		2SD78							
2N3726									DUAL
2N3727									DUAL
2N3728									
2N3729									
2N3740	2SB502				2SB128				
2N3741	2SB502				2SB128				
2N3766		2SD73					2SD47		
2N3767		2SD73					2SD47		
2N3789	2SB554								
2N3790	2SB554								
2N3791	2SB554								
2N3792	2SB554								
2N3800									DUAL
2N3801									DUAL
2N3802									DUAL
2N3803									DUAL
2N3806									DUAL
2N3807									DUAL
2N3808									DUAL
2N3809									DUAL
2N3804									DUAL
2N3804A									DUAL
2N3805									DUAL
2N3805A									DUAL
2N3810									DUAL
2N3810A									DUAL
2N3811									DUAL
2N3811A									DUAL
2N3903	2SC482					2SC46		2SC875	
2N3904	2SC482					2SC46		2SC875	
2N3905	2SA5Q1		2SA673		2SA546				
2N3906	2SA501		2SA673		2SA546				
2N3923			2SC154A						
2N3946	2SC108A						2SC632A		
2N3947	2SC108A						2SC632A		
2N3962							2SA705		
2N3964							2SA705		
2N3965							2SA705		
2N4013		2SD78						2SD330	
2N4014		2SD78							
2N4015									DUAL
2N4016									DUAL
2N4017									DUAL

FAIRCHILD

TYPE	USE	MATERIAL	POLARITY	MAXIMUM RATINGS				ELECTRICAL CHARACTERISTICS													OUTLINE TO.	NOTE	
				Pc 25°C (mW)	Tj (°C)	Vce (V)	Vcbo (V)	Ic (mA)	Icbo (μA)	Vce(V) min.	h _{FE} max.	h _{FE} lc(mA)	f _{ie} (Ω)	h _{re} (×10)	h _{oe} (μS)	f _T f _{max} (MHz)	NF (dB)	Cob (pF)	Coxbr (ps)				
2N4018	A	S	P	600	200	45	45	200	10n	50	100	600	1	400	20	10	50		10	6		5	
2N4019	A	S	P	600	200	45	45	200	10n	30	250	600	1	480	20	10	50		4	6		5	
2N4020	A	S	P	600	200	45	45	200	10n	30	250	600	1	480	20	10	50		2	6		5	
2N4021	A	S	P	600	200	60	60	200	10n	50	100	500	1	330	17	10	40		3	6		5	
2N4022	A	S	P	600	200	60	60	200	10n	50	250	600	1	480	20	10	50		2	6		5	
2N4023	A	S	P	600	200	45	45	200	10n	30	250	600	1	480	20	10	50		2	6		5	
2N4024	A	S	P	600	200	60	60	200	10n	50	100	500	1	330	17	10	40		3	6		5	
2N4025	A	S	P	600	200	60	60	200	10n	50	250	600	1	480	20	10	50		2	6		5	
2N4030	A	S	P	800	200	60	60	1A	50n	50	40	120	100									5	
2N4031	A	S	P	800	200	80	80	1A	50n	60	40	120	100									5	
2N4032	A	S	P	800	200	60	60	1A	50n	50	100	300	100									5	
2N4033	A	S	P	800	200	80	80	1A	50n	60	100	300	100									5	
2N4034	A/S	S	P	360	200	40	40	100			70	200	10		8	3	24	400	6			18	
2N4035	A/S	S	P	360	200	40	40	100			150	300	10		12	4	40	400	6			18	
2N4046	SH	S	N	800	200	50	30	500	1.7	40	60	150	100						12			5	
2N4047	SH	S	N	800	200	80	50	500	1.7	60	60	150	100						10			5	
2N4121	A/S	S	P	200	125	40	40	100			70	200	10		8	3	24	450	6			18	
2N4122	A/S	S	P	200	125	40	40	100			150	300	10		12	4	40	450	6			18	
2N4123	A/S	S	N	625	150	40	30	200	50n	20	50	150	2	125					6			92	
2N4124	A/S	S	N	625	150	30	25	200	50n	20	120	360	2	250					5			92	
2N4125	A/S	S	P	625	150	30	30	200	50n	20	50	150	2	125					5			92	
2N4126	A/S	S	P	625	150	25	25	200	50n	20	120	360	2	250					4			92	
2N4208	SH	S	P	300	200	12	12	50			30	120	10				850			3		18	
2N4209	SH	S	P	300	200	15	15	50			50	120	10				850			3		18	
2N4234	P	S	P	6W		40	40	1A	100	40	30	150	250	25					100			5	
2N4235	P	S	P	6W		60	60	1A	100	60	30	150	250	25					100			5	
2N4236	P	S	P	6W		80	80	1A	100	80	30	150	250	25					100			5	
2N4237	P	S	N	800		50	40	1A	100	50	30	150	250	30					100			5	
2N4238	P	S	N	800		80	60	1A	100	80	30		500	30					100			5	
2N4239	P	S	N	800		100	80	1A	100	100	15		1A	30					100			5	
2N4248	A	S	P	200	125	40	40		10n	40	50		0.1	525								18	
PN4248	A	S	P	625	150	40	40		10n	40	50		0.1	525								92	
2N4249	A	S	P	200	125	60	60		10n	40	100	300	0.1	325	17	10	40		3	6		18	
PN4249	A	S	P	625	150	60	60		10n	40	100	300	0.1	325	17	10	40		3	6		92	
2N4250	A	S	P	200	125	40	40		10n	40	250	700	0.1	525	20	10	50		2	6		18	
2N4250A	A	S	P	200	125	60	60		10n	50	250	700	0.1	525	20	10	50		2	6		92	
PN4250A	A	S	P	625	150	60	60		10n	50	250	700	0.1	525	20	10	50		2	6		92	
2N4258	SH	S	P	200	125	12	12	50			30	120	10									18	
2N4258A	SH	S	P	200	125	12	12	50			30	120	10									18	
PN4258	SH	S	P	625	150	12	12	50			30	120	10									92	
PN4258A	SH	S	P	625	150	12	12	50			30	120	10									92	
2N4264	SH	S	N	1W	150	30	15	200			40	160	10				300					92	
2N4265	SH	S	N	1W	150	30	12	200			100	400	10				300					92	
2N4274	SH	S	N	200	125	30	12	500	10	20							400					18	
2N4275	SH	S	N	200	125	40	15	500	10	20							400					18	
2N4342	FET	S		200	125																	18	
2N4343	FET	S		200	125															5		18	
2N4354	A	S	P	350	125	60	60	500	50n	50	50	500	10						1.5			18	
MPS4354	A	S	P	625	150	60	60	500	50n	50	150	500	10						3			5	
2N4355	A	S	P	350	125	60	60	500	50n	50	100	400	10						3			92	
MPS4355	A	S	P	625	150	60	60	500	50n	50	100	400	10						3			5	
2N4356	A	S	P	350	125	80	80	500	50n	50	50	250	10						3			92	
MPS4356	A	S	P	625	150	80	80	500	50n	50	50	250	10						3			5	
2N4398	P	S	P			40	40	30A	1000	40	15	60	15A	40								92	
																						3	

TYPE	TOSHIBA	NEC	HITACHI	MITSUBISHI	MATSUSHITA	FUJITSU	SONY	SANYO	NOTE
2N4018									DUAL
2N4019									DUAL
2N4020									DUAL
2N4021									DUAL
2N4022									DUAL
2N4023									DUAL
2N4024									DUAL
2N4025									DUAL
2N4030	2SA484	2SB504			2SA546A				
2N4031	2SA484	2SB504			2SA546A				
2N4032	2SA484	2SB504			2SA546A				
2N4033	2SA484	2SB504			2SA546A				
2N4034	2SA504		2SA537			2SA523			
2N4035	2SA504		2SA537			2SA523			
2N4046		2SD78							
2N4047		2SD78							
2N4121	2SA504		2SA537			2SA523			
2N4122	2SA504		2SA537			2SA523			
2N4123	2SC109		2SC112			2SC189			
2N4124	2SC109		2SC112			2SC189			
2N4125		2SA552						2SA532	
2N4126		2SA552						2SA532	
2N4208				2SA696			2SA678		
2N4209				2SA696			2SA678		
2N4234					2SB449	2SB456		2SB474	
2N4235					2SB449	2SB456		2SB474	
2N4236						2SB456		2SB474	
2N4237		2SD79	2SD121		2SC697	2SD183			
2N4238		2SD79	2SD121		2SC697	2SD183			
2N4239		2SD79	2SD121		2SC697	2SD183			
2N4248	2SA493								
PN4248	2SA493								
2N4249									
PN4249									
2N4250									
2N4250A	2SA493								
PN4250	2SA493								
PN4250A	2SA493								
2N4258		2SA712	2SA548	2SA458		2SA559			
2N4258A		2SA712							
PN4258		2SA712	2SA548	2SA458		2SA559			
PN4258A		2SA712							
2N4264					2SC827	2SC849			
2N4265					2SC827	2SC849			
2N4274		2SC1071	2SC321			2SC1071			
2N4275		2SC1071	2SC321			2SC1071			
2N4342									FET
2N4343									
2N4354	2SA560	2SA606				2SA581			
MPS4354	2SA560	2SA606				2SA581			
2N4355	2SA560	2SA606				2SA581			
MPS4355	2SA560	2SA606				2SA581			
2N4356	2SA560	2SA606							
MPS4356	2SA560	2SA606							
2N4398									

FAIRCHILD

TYPE	USE	MATERIAL	POLARITY	MAXIMUM RATINGS				ELECTRICAL CHARACTERISTICS											OUTLINE TO	NOTE									
				Pc	Tj	Ves	Vceo	Ic	Icso		Ic		Ife	hie	hre	hoe	f _r	NF			Cob	Coxrby							
				25°C (mW)	(°C)	(V)	(V)	(mA)	(μA)	Vce(V)	min.	max.	(mA)	(Ω)	(×10)	(μΩ)	100 MHz	(dB)			(pF)	(ps)							
2N4399	P	S	P			60	60	30A	1000	60	15	60	15A	40											3				
2N4400	A/S	S	N	625	150	60	40	600			50	150	150	130	7.5	8	30	200								92			
2N4401	A/S	S	N	625	150	60	40	600			100	300	150	270	15	8	30	250								92			
2N4402	A/S	S	P	625	150	40	40	600			50	150	150	190	7.5	8	100	150								92			
2N4403	A/S	S	P	625	150	40	40	600			100	300	150	280	15	8	100	200								92			
2N4409		S	N	625	150	80	50	250	10n	60	60	400	10													92			
2N4410		S	N	625	150	120	80	250	10n	100	60	400	10													92			
2N4888	A	S	P	300	125	150	150	100	50n	100	40	400	10			20		40						4		5			
PN4888	A	S	P	625	150	150	150	100	50n	100	40	400	10			20		40						4		92			
2N4889	A	S	P	300	125	150	150	100	10n	100	80	300	10			12	5	25			3			4		5			
PN4889	A	S	P	625	150	150	150	100	10n	100	80	300	10			12	5	25			3			4		92			
2N4895	P	S	N	800	200	120	60	5A			40	120	2A											80		5			
2N4896	P	S	N	800	200	120	60	5A			100	300	2A											80		5			
2N4897	P	S	N	800	200	150	80	5A			40	120	2A											80		5			
2N4901	P	S	P	87W	200	40	40	5A			20	800	1A	4												3			
2N4902	P	S	P	87W	200	60	60	5A			20	800	1A	4												3			
2N4903	P	S	P	87W	200	80	80	5A			20	800	1A	4												3			
2N4904	P	S	P	87W	200	40	40	5A			25	100	2.5A	4												3			
2N4905	P	S	P	87W	200	60	60	5A			25	100	2.5A	4												3			
2N4906	P	S	P	87W	200	80	80	5A			25	100	2.5A	4												3			
2N4907	P	S	P	150W	200	40	40	10A			20	80	4A	4												3			
2N4908	P	S	P	150W	200	60	60	10A			20	80	4A	4										600		3			
2N4909	P	S	P	150W	200	80	80	10A			20	80	4A	4										600		3			
2N4910	P	S	N	25W	200	40	40	1A	100	40	20	100	500	25										100		66			
2N4911	P	S	N	25W	200	60	60	1A	100	60	20	100	500	25										100		66			
2N4912	P	S	N	25W	200	80	80	1A	100	80	20	100	500	25										100		66			
2N4231	P	S	N	35W	200	40	40	3A	50	40	25	100	1.5A	20										200		66			
2N4232	P	S	N	35W	200	60	60	3A	50	60	25	100	1.5A	20										200		66			
2N4233	P	S	N	35W	200	80	80	3A	50	80	25	100	1.5A	20										200		66			
2N4898	P	S	P	25W	200	40	40	1A	100	40	20	100	500	25										100		66			
2N4899	P	S	P	25W	200	60	60	1A	100	60	20	100	500	25										100		66			
2N4900	P	S	P	25W	200	80	80	1A	100	80	20	100	500	25										100		66			
2N4913	P	S	N	87W		40	40	5A			25	100	2.5A	20												3			
2N4914	P	S	N	87W		60	60	5A			25	100	2.5A	20												3			
2N4915	P	S	N	87W		80	80	5A			25	100	2.5A	20												3			
2N4916	A/S	S	P	200	125	30	30	100			70	200	10											450	6		18		
PN4916	A/S	S	P	625	150	30	30	100			70	200	10											450	6		92		
2N4917	A/S	S	P	200	125	30	30	100			150	300	10											450	6		18		
PN4917	A/S	S	P	625	150	30	30	100			150	300	10											450	6		92		
2N4960	A/S	S	N	800	200	60	60	1A	10n	50	100	300	150											250			5		
2N4961	A/S	S	N	500	200	80	80	1A	10n	50	100	300	150											250			5		
2N4962	A/S	S	N	800	200	60	60	1A	10n	50	100	300	150											250			18		
2N4963	A/S	S	N	500	200	80	80	1A	10n	50	100	300	150											250			18		
2N4002	P	S	N	50W	200			5A			30	90	2.5A											60			59		
2N5003	P	S	P	50W	200			5A			30	90	2.5A											60			59		
2N5004	P	S	N	50W	200			5A			70	200	2.5A											70			59		
2N5005	P	S	P	50W	200			5A			70	200	2.5A											70			59		
2N5022	S	S	P	1W	200	50	50	1A			25	100	500														5		
2N5023	S	S	P	1W	200	30	30	1A			40	100	500														5		
2N5058	A	S	N	1W	175	300	300	150	50n	100	35	150	30														5		
2N5059	A	S	N	1W	175	250	250	150	50n	100	30	150	30														5		
2N5067	P	S	N	87W		40	40	5A			20	80	1A	20													3		
2N5068	P	S	N	87W		60	60	5A			20	80	1A	20													3		
2N5069	P	S	N	87W		80	80	5A			20	80	1A	20													3		
2N5086	A	S	P	1W	150	50	50	50	10n	10	150	500	0.1	370										40		3		92	

TYPE	TOSHIBA	NEC	HITACHI	MTSUBISHI	MATSUSHITA	FUJITSU	SONY	SANYO	NOTE
2N4399									
2N4400	2SC503	2SC1008					2SC1124		
2N4401	2SC503	2SC1008					2SC1124		
2N4402	2SA682	2SA717							
2N4403	2SA682	2SA717							
2N4409									
2N4410									
2N4888									
PN4888									
2N4889									
PN4889									
2N4895					2SC697A		2SC299		
2N4896					2SC697A		2SC299		
2N4897					2SC697A		2SC299		
2N4901	2SB555	2SB539	2SA753				2SB520		
2N4902	2SB555	2SB539	2SA753				2SB520		
2N4903	2SB555	2SB539	2SA753				2SB520		
2N4904	2SB555	2SB539	2SA753				2SB520		
2N4905	2SB555	2SB539	2SA753				2SB520		
2N4906	2SB555	2SB539	2SA753				2SB520		
2N4907	2SB554								
2N4908	2SB554								
2N4909	2SB554								
2N4910		2SD73				2SD175	2SD88		
2N4911		2SD73				2SD175	2SD88		
2N4912		2SD73				2SD175	2SD88		
2N4231		2SD73				2SD175	2SD88		
2N4332		2SD73				2SD175	2SD88		
2N4233		2SD73				2SD175	2SD88		
2N4898	2SB502				2SB128				
2N4899	2SB502				2SB128				
2N4900	2SB502				2SB128				
2N4913	2SC1434	2SD181A					2SC808		
2N4914	2SC1434	2SD181A					2SC808		
2N4915	2SC1434	2SD181A					2SC808		
2N4916		2SA552	2SA548		2SA550A	2SA558		2SA532	
PN4916		2SA552						2SA532	
2N4917		2SA552	2SA548		2SA550A	2SA558		2SA532	
PN4917		2SA552						2SA532	
2N4960		2SC97A				2SC1069			
2N4961		2SC97A				2SC1069			
2N4962		2SC97A				2SC1069			
2N4963		2SC97A				2SC1069			
2N5002			2SD50			2SD50	2SD47		
2N5003	2SB530	2SB506					2SB518		
2N5004			2SD50			2SD50	2SD47		
2N5005	2SB530	2SB506					2SB518		
2N5022		2SB239				2SB456			
2N5023		2SB239				2SB456			
2N5058									
2N5059									
2N5067	2SC1433						2SC808		
2N5068	2SC1433						2SC808		
2N5069	2SC1433						2SC808		
2N5086							2SA705		

FAIRCHILD

TYPE	USE	MATERIAL	POLARITY	MAXIMUM RATINGS					ELECTRICAL CHARACTERISTICS											OUTLINE TO.	NOTE			
				Pc 25°C (mW)	Tj (°C)	Ves (V)	Vceo (V)	Ic (mA)	Icbo		hre			hfe	hfe (Ω)	hre (×10)	hoe (μS)	fT **fαβ (MHz)	NF (dB)			Cob (pF)	Cox/bt (ps)	
									(μA)	Va(V)	min.	max.	Ic(mA)											
2N5087	A	S	P	1W	150	50	50	50			250	800	0.1	600					40	2		92		
2N5088	A	S	N	625	150	35	30	50	50n	20	300	900	0.1	900					50	3		92		
2N5089	A	S	N	625	150	30	25	50	50n	15	400	1200	0.1	1150					50	2		92		
2N5126	A	S	N	200	125	20	20		1n	10	20	350	4	200						5.5			18	
PN5126	A	S	N	625	150	20	20		1n	10	20	350	4	200						5.5			92	
2N5127	A	S	N	200	125	20	12	100	50n	10	15	300	2										18	
2N5128	A/S	S	N	200	125	15	12		50n	10	35	350	50										5	
PN5128	A/S	S	N	625	150	15	12		50n	10	35	350	50										92	
2N5129	A/S	S	N	300	125	15	12		50n	10	35	350	50										18	
PN5129	A/S	S	N	625	150	15	12		50n	10	35	350	50										92	
2N5130	A	S	N	200	125	30	12	50	50n	10	15	250	8							4			18	
PN5130	A	S	N	300	150	30	12	50	50n	10	15	250	8							4			92	
2N5131	A	S	N	200	125	20	15		50n	10	30	500	10	310									18	
PN5131	A	S	N	625	150	20	15		50n	10	30	500	10	310									92	
2N5131	A	S	N	200	125	20	20		50n	10	30	400	10	340						4			18	
PN5132	A	S	N	625	150	20	20		50n	10	30	400	10	340						4			92	
2N5133	A	S	N	200	125	20	18		50n	15	60	1000	1	570									18	
PN5133	A	S	N	625	150	20	18		50n	15	60	1000	1	570									92	
2N5134	SH	S	N	200	125	20	10	100	1	15	20	150	10										18	
PN5134	SH	S	N	625	150	20	10	100	1	15	20	150	10							250			92	
2N5135	A	S	N	300	125	30	30	200	0.3	15	50	600	10							40			5	
PN5135	A	S	N	625	150	30	30	200	0.3	15	50	600	10							40			92	
2N5136	A	S	N	300	125	30	30	300	0.1	20	20	400	150							40			5	
PN5136	A	S	N	625	150	30	30	500	0.1	20	20	400	150							40			92	
2N5137	A	S	N	220	125	30	30	500	0.1	20	20	400	150							40			18	
PN5137	A	S	N	625	150	30	30	500	0.1	20	20	400	150							40			92	
2N5138	A	S	P	200	125	30	30		50n	20	50	800	0.1	520									18	
PN5138	A	S	P	625	150	30	30		50n	20	50	800	0.1	520									92	
2N5139	A/S	S	P	200	125	20	20	100		40	150	10								300			18	
PN5139	A/S	S	P	625	150	20	20	100		40	150	10								300			92	
2N5142	A/S	S	P	300	125	20	20	500		30		50											5	
PN5142	A/S	S	P	625	150	20	20	500		30		50											92	
2N5143	A/S	S	P	200	125	20	20	500		30		50											18	
PN5143	A/S	S	P	625	150	20	20	500		30		50											92	
2N5209	A	S	N	625	150	50	50	50	50n	35	100	300	0.1	370						30	3		92	
2N5210	A	S	N	625	150	50	50	50	50n	35	200	600	0.1	570						30	2		92	
2N5219	A	S	N	625	150	20	15	100	0.1	10	35	500	2	770						150			92	
2N5223	A	S	N	625	150	25	20	100	0.1	10	50	800	2	825						150			92	
2N5220	A	S	N	625	150	15	15	500	0.1	10	30	600	50	915						100			92	
2N5221	A	S	P	625	150	15	15	500	0.1	10	30	600	50	915						100			92	
2N5224	S	S	N	625	150	25	12	100	0.5	15	40	400	10							250			92	
2N5225	A	S	N	625	150	25	25	500	0.3	15	30	600	50	915						50			92	
2N5226	A	S	P	625	150	20	25	500	0.3	15	30	600	50	915						50			92	
2N5227	A	S	P	625	150	30	30	50	0.1	10	50	700	2							100			92	
2N5228	S	S	P	625	150	5	5	50		15		10								300			92	
2N5301	P	S	N	200W	200	40	40	30A	1000	40	15	60	15A	40						2			3	
2N5302	P	S	N	200W	200	60	60	30A	1000	60	15	60	10A	40						2			3	
2N5303	P	S	N	200W	200	80	80	20A	1000	80	15	60	10A	40						2			3	
2N5320	P	S	N	10W	200	100	75	2A			30	130	500	5									5	
2N5321	P	S	N	10W	200	75	50	2A			40	250	500	5									5	
2N5322	P	S	P	10W	200	100	75	2A			30	130	500	5									5	
2N5323	P	S	P	10W	200	75	50	2A			40	250	500	5									5	
2N5334	P	S	N	6W	200	60	60	3A	5	60	30	150	1A										5	
2N5335	P	S	N	6W	200	80	80	3A	5	80	30	150	1A										5	
2N5336	P	S	N	6W	200	80	80	5A	10	80	30	120	2A										5	

TYPE	TOSHIBA	NEC	HITACHI	mitsubishi	MATSUSHITA	FUJITSU	SONY	SANYO	NOTE
2N5087							2SA705		
2N5088	2SCB86A			2SC1313	2SC1345				
2N5089	2SC1386A			2SC1313	2SC1345				
2N5126		2SC943	2SC281					2SC536	
PN5126	2SC594	2SC594		2SC594		2SC285A		2SC875	
2N5127	2SC504			2SC306		2SC200			
2N5128	2SC504			2SC306		2SC200			
PN5128	2SC504			2SC306		2SC200			
2N5129	2SC504			2SC306		2SC200			
PN5129	2SC504			2SC306		2SC200			
2N5130	2SC979			2SC302				2SC933	
PN5130	2SC979			2SC302				2SC933	
2N5131				2SC303	2SC456			2SC876	
PN5131				2SC303	2SC456			2SC876	
2N5132				2SC303	2SC456			2SC876	
PN5132				2SC303	2SC456			2SC876	
2N5133			2SC166						
PN5133						2SC188			
2N5134	2SC504			2SC306		2SC200			
PN5134	2SC504			2SC306		2SC200			
2N5135				2SC304		2SC198A		2SC875	
PN5135				2SC304		2SC198A		2SC875	
2N5136				2SC304		2SC198A		2SC875	
PN5136				2SC304		2SC198A		2SC875	
2N5137				2SC304		2SC198A		2SC875	
PN5137				2SC304		2SC198A		2SC875	
2N5138	2SA482	2SA606							
PN5138	2SA482	2SA606							
2N5139		2SA552			2SA546			2SA532	
PN5139		2SA552			2SA546			2SA532	
2N5142	2SA513	2SA571	2SA537						
PN5142	2SA513	2SA571	2SA537						
2N5143	2SA513	2SA571	2SA537						
PN5143	2SA513	2SA571	2SA537						
2N5209									
2N5210									
2N5219		2SC38		2SC774			2SC352		
2N5223		2SC38		2SC774			2SC352		
2N5220	2SC367								
2N5221	2SA467								
2N5224		2SC97	2SC479			2SC233			
2N5225	2SC498								
2N5226	2SA498								
2N5227									
2N5228		2SA552							
2N5301	2SD113								
2N5302	2SD113								
2N5303	2SD55								
2N5320		2SD49					2SD49		
2N5321		2SD71					2SD49		
2N5322									
2N5323									
2N5334					2SC697A				
2N5335					2SC697A				
2N5336									

FAIRCHILD

TYPE	USE	MATERIAL	POLARITY	MAXIMUM RATINGS					ELECTRICAL CHARACTERISTICS											OUTLINE TO.	NOTE								
				Pc 25°C (mW)	T (°C)	Vce (V)	Vceo (V)	Ic (mA)	Icbo (μ A)	VceV (V)	hfe		hfe	hie (Ω)	hre ($\times 10$)	hoe (μ C)	f _T **f _{ce} (MHz)	NF (dB)	Cob (pF)			Coxb ¹ (ps)							
2N5337	P	S	N	6W	200	80	80	5A	10	80	30	120	2A												5				
2N5338	P	S	N	6W	200	100	100	5A	10	100	60	240	2A													5			
2N5339	P	S	N	6W	200	100	100	5A	10	100	60	240	2A													5			
2N5400	A	S	P	625	150	130	120	600	0.1	100	40	180	10	115											8	6	92		
2N5401	A	S	P	625	150	160	150	600	50n	120	60	240	10	120											8	6	92		
2N5455	S	S	P	340	200	25	25	300			30	120	30														18		
2N5456	S	S	P	340	200	15	15	300			30	120	30														18		
2N5457	FET	S	N	625	150																				3		92		
2N5458	FET	S	N	625	150																				3		92		
2N5459	FET	S	N	625	150																				3		92		
2N5484	FET	S	N	625	150																				2.5		92		
2N5485	FET	S	N	625	150																				2.5		92		
2N5486	FET	S	N	625	150																				2.5		92		
2N5550	A	S	N	625	150	160	140	600	0.1	100	60	250	10	125											10	6	92		
MP5551M	A	S	N	625	150	180	160	600	50n	120	80	250	10	125											8	6	92		
2N5668	FET	S	N	625	150																					2.5		92	
2N5669	FET	S	N	625	150																					2.5		92	
2N5670	FET	S	N	625	150																					2.5		92	
2N5679	P	S	P	10W	200	100	100	1A	1	100	40	150	250	40											30		50	5	
2N5680	P	S	P	10W	200	120	120	1A	1	120	40	150	250	40											30		50	5	
2N5681	P	S	N	10W	200	100	100	1A	1	100	40	150	250	40											30		50	5	
2N5682	P	S	N	10W	200	120	120	1A	1	120	40	150	250	40											30		50	5	
2N5769	S	S	N	625	150	-40	15	500	0.4	20	20		10														4	92	
2N5770	A	S	N	1W	150	30	15	50	10n	15	20		3														1.7	92	
2N5771	S	S	P	625	150	15	15	50	10n	8	50	120	10															92	
2N5830	A	S	N	625	150	120	100	600	50n	100	80	500	10	60	6													92	
2N5831	A	S	N	625	150	160	140	600	50n	120	80	250	10	60	6													92	
2N5832	A	S	N	625	150	160	140	600	50n	120	175	500	10	125	6													92	
2N5833	A	S	N	625	150	200	180	600	10n	160	50	250	10	50	6													92	
2N5845	SH	S	N	625	150	50	40	600	0.5	40	25	150	500															92	
2N585A	SH	S	N	625	150	50	40	600	0.5	40	35	150	500															92	
2N5855	A	S	P	750	135	60	60	1A	0.1	40	50	300	150														15	5	
PN5855	A	S	P	625	150	60	60	1A	0.1	40	50	300	150														15	92	
2N5856	A	S	N	750	135	60	60	1A	0.1	40	50	300	150														15	5	
PN5856	A	S	N	625	150	60	60	1A	0.1	40	50	300	150														15	92	
2N5857	A	S	P	750	135	80	80	1A	0.1	60	50	300	150														15	5	
PN5857	A	S	P	625	150	80	80	1A	0.1	60	50	300	150														15	92	
2N5858	A	S	N	750	135	80	80	1A	0.1	60	50	300	150														15	5	
PN5858	A	S	N	625	150	80	80	1A	0.1	60	50	300	150														15	92	
2N5871	P	S	P	100W	200	60	60	7A	250	60	20	100	2.5A	20													300	3	
2N5872	P	S	P	100W	200	80	80	7A	250	80	20	100	2.5A	20													300	3	
2N5873	P	S	N	100W	200	60	60	7A	250	60	20	100	2.5A	20													250	3	
2N5874	P	S	N	100W	200	80	80	7A	250	80	20	100	2.5A	20													250	3	
2N5875	P	S	P	150W	200	60	60	10A	500	60	20	100	4A	20													500	3	
2N5876	P	S	P	150W	200	80	80	10A	500	80	20	100	4A	20													500	3	
2N5877	P	S	N	150W	200	60	60	10A	500	60	20	100	4A	20													300	3	
2N5878	P	S	N	150W	200	80	80	10A	500	80	20	100	4A	20													300	3	
2N5879	P	S	P	160W	200	60	60	15A	500	60	20	100	6A	20													600	3	
2N5880	P	S	P	160W	200	80	80	15A	500	80	20	100	6A	20													600	3	
2N5881	P	S	N	160W	200	60	60	15A	500	60	20	100	6A	20													400	3	
2N5882	P	S	N	160W	200	80	80	15A	500	80	20	100	6A	20													400	3	
2N5883	P	S	P	200W	200	60	60	25A	1000	60	20	100	10A	20													1000	3	
2N5884	P	S	P	200W	200	80	80	25A	1000	80	20	100	10A	20													1000	3	
2N5885	P	S	N	200W	200	60	60	25A	1000	60	20	100	10A	20													500	3	
2N5886	P	S	N	200W	200	80	80	25A	1000	80	20	100	10A	20													500	3	

TYPE	TOSHIBA	NEC	HITACHI	MITSUBISHI	MATSUSHITA	FUJITSU	SONY	SANYO	NOTE
2N5337									
2N5338									
2N5339									
2N5400	2SA516A	2SA653		2SA698					
2N5401		2SA653							
2N5455	2SA478	2SA712							
2N5456	2SA478	2SA712							
2N5457									FET
2N5458									FET
2N5459									FET
2N5484									FET
2N5485									FET
2N5486									FET
2N5550	2SC783		2SC1409A						
MPS5551M	2SC783		2SC1409A						
2N5668									FET
2N5669									FET
2N5670									FET
2N5679				2SB528					
2N5680				2SB528					
2N5681				2SD358					
2N5682				2SD358					
2N5769	2SC108					2SC233			
2N5770									
2N5771		2SA552				2SA559	2SA678		
2N5830	2SC510			2SC310			2SC1124		
2N5831	2SC510			2SC310			2SC1124		
2N5832	2SC510			2SC310			2SC1124		
2N5833									
2N5845	2SC503		2SC479			2SC906			
2N5845A	2SC503		2SC479			2SC906			
2N5855			2SA743A						
PN5856			2SC1212A						
2N5856			2SC1212A						
PN5856			2SC1212A						
2N5857			2SA743A						
PN5857			2SA743A						
2N5858			2SC1212A						
PN5858			2SC1212A						
2N5871	2SB558	2SB539							
2N5872	2SB558	2SB539							
2N5873	2SD113					2SD53			
2N5874	2SD113					2SD53			
2N5875	2SB554								
2N5876	2SB554								
2N5877	2SC1434	2SD132				2SD54			
2N5878	2SC1434	2SD132				2SD54			
2N5879	2SB554								
2N5880	2SB554								
2N5881	2SD55								
2N5882	2SD55								
2N5883									
2N5884									
2N5885	2SD114								
2N5886	2SD113								

FAIRCHILD

TYPE	USE	MATERIAL	POLARITY	MAXIMUM RATINGS				ELECTRICAL CHARACTERISTICS											OUTLINE TO.	NOTE				
				Pc 25°C (mW)	Tj (°C)	Vce (V)	Vceo (V)	Ic (mA)	Icbo (μA)	Vce(V)	hfe		hfe (Ω)	hfe (×10)	hoe (μS)	f _T *f _{10p} **f _{10p} (MHz)	NF (dB)	Cob (pF)			Coxb/tp (ps)			
2N5910	SH	S	P	310	135	20	20	50			30	120	10										18	
PN5910	SH	S	P	625	150	20	20	50			30	120	10										92	
2N5961	A	S	N	625	150	60	60	50	2n	45	150	700	10	575									92	
2N5962	A	S	N	625	150	45	45	50	2n	30	600	1400	10	1300									92	
2N5963	A	S	N	625	150	30	30	50	2n	20	1200	2200	10	2100									92	
2N6121	P	S	N	40W	150	45	45	4A	100		25	100	1.5A	25									220	
2N6122	P	S	N	40W	150	60	60	4A	100		25	100	1.5A	25									220	
2N6123	P	S	N	40W	150	80	80	4A	100		20	80	1.5A	25									220	
2N6124	P	S	P	40W	150	45	45	4A	100		25	100	1.5A	25									220	
2N6125	P	S	P	40W	150	60	60	4A	100		25	100	1.5A	25									220	
2N6126	P	S	P	40W	150	80	80	4A	100		20	80	1.5A	25									220	
2N6129	P	S	N	50W	150	40	40	7A	100		20	100	2.5A	25									220	
2N6130	P	S	N	50W	150	60	60	7A	100		20	100	2.5A	25									220	
2N6131	P	S	N	50W	150	80	80	7A	100		20	100	2.5A	25									220	
2N6132	P	S	P	50W	150	40	40	7A	100		20	100	2.5A	25									220	
2N6133	P	S	P	50W	150	60	60	7A	100		20	100	2.5A	25									220	
2N6134	P	S	P	50W	150	80	80	7A	100		20	100	2.5A	25									220	
2N6233	P	S	N	50W	200	250	225	10A	100	250	15	125	1A										66	
2N6234	P	S	N	50W	200	300	275	10A	100	300	25	125	1A										66	
2N6235	P	S	N	50W	200	350	325	10A	100	350	25	125	1A										66	
SE9051	P	S	N	50W	200	300	275	10A	100	300	20	100	1A										66	
SE9052	P	S	N	50W	200	325	325	10A	100	325	20	100	1A										66	

SSDI

TYPE	USE	MATERIAL	POLARITY	MAXIMUM RATINGS				ELECTRICAL CHARACTERISTICS										OUTLINE TO	NOTE					
				Pc 25°C (mW)	Tj (°C)	Vca (V)	Vco (V)	Ic (mA)	Icao (μA)	Vca(V)	hfe		hfe (Ω)	hre (x10)	hoe (μΩ)	fT *fTob (MHz)	NF (dB)			Cob (pF)	Coxrbb (ps)			
SPT2770	P	S	N	200W	175	75	60	20A			40		5A									63		
2N3055	P	S	N	115W	200	100	60	15A			20	70	4A										3	
SPT3055-1	P	S	N	115W	200	80	50	15A			15		3A	10									3	
2N3232	P	S	N	117W	200	60	60	7.5A			18	55	3A	1									3	
2N3235	P	S	N	117W	200	55	55	15A			20	70	4A	1									3	
2N3439	P	S	N	10W	200	450	350	1A	20	360	40	160	20	25							10		5	
2N3440	P	S	N	10W	200	300	250	1A	20	250	40	160	20	25							10		5	
2N3713	P	S	N	150W	200	80	60	10A			25	90	1A	4									3	
2N3714	P	S	N	150W	200	100	80	10A			25	90	1A	4									3	
2N3715	P	S	N	150W	200	80	60	10A			50	150	1A	4									3	
2N3716	P	S	N	150W	200	100	80	10A			50	150	1A	4									3	
SPT3738	P	S	N	20W	175	250	225	3A			50		250	10									66	
2N3771	P	S	N	150W	200	50		30A			15	60	15A	40									3	
2N3772	P	S	N	150W	200	100		30A			15	60	10A	40									3	
2N3773	P	S	N	150W	200	160		30A			15	60	8A	40									3	
2N3789	P	S	P	150W	200	60	60	10A			25	90	1A				4						3	
2N3790	P	S	P	150W	200	80	80	10A			25	90	1A				4						3	
2N3791	P	S	P	150W	200	60	60	10A			50	150	1A				4						3	
2N3792	P	S	P	150W	200	80	80	10A			50	150	1A				4						3	
2N4000	P	S	N	15W	200	100	80	1A			30	120	500	2									5	
2N4001	P	S	N	15W	200	120	100	1A			40	120	500	2									5	
2N4398	P	S	P	200W	200	40	40	30A	1000	40	15	60	15A	40			4						3	
2N4399	P	S	P	200W	200	60	60	30A	1000	60	15	60	15A	40			4						3	
SPT4625	P	S	N	87W	175	450	400	10A			30	100	2A										3	
2N5281	P	S	P	2W	200	175	150	1A	1		20	200	1										5	
2N5282	P	S	P	2W	200	325	300	1A	1		20	200	1										5	
2N5301	P	S	N	200W	200	40	40	30A	1000	40	15	60	15A	40			2						3	
2N5302	P	S	N	200W	200	60	60	30A	1000	60	15	60	15A	40			2						3	
2N5303	P	S	N	200W	200	80	80	20A	1000	80	15	60	10A	40			2						3	
2N5745	P	S	P	200W	200	80	80	20A	1000	80	15	60	10A	40			2						3	
SPT6145	P	S	P	10W	200	350	350	2A			20		100	3									MD14	

DATI MECCANICI

TO-1 CASE 149-02

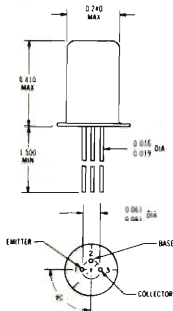

TO-3 CASE 11

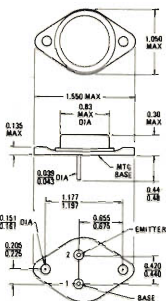

TO-5 CASE 31(1)

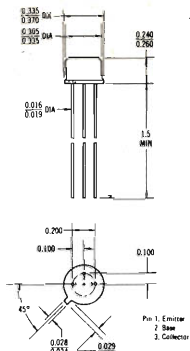

TO-12 CASE 34A

Collector connected to case

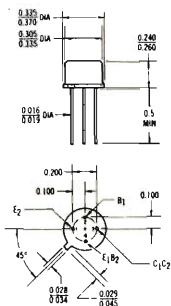

TO-17 CASE 21

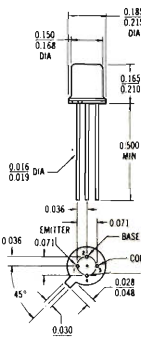

TO-18 CASE 22(1)

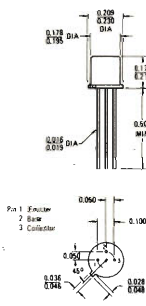

TO-71 CASE 35



2N3800 thru 2N3805

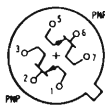

PINS 4 AND 8 OMITTED

TO-36 CASE 5

Collector connected to case

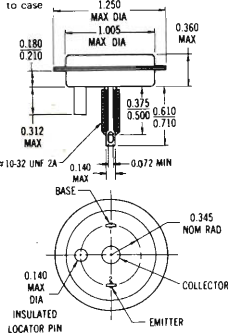

TO-37 CASE 39

Collector connected to case

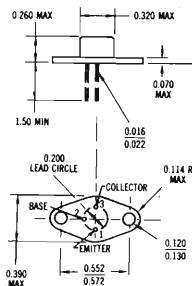

TO-39 CASE 79

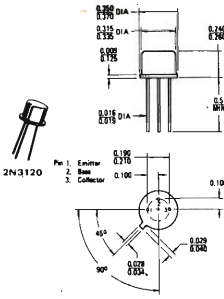

TO-41 CASE 4-04

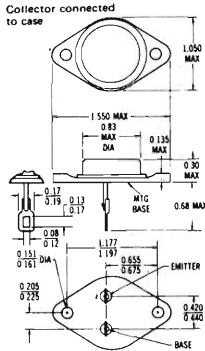

TO-46 CASE 26

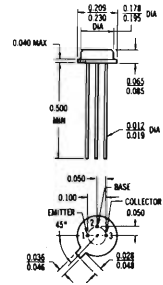

TO-48 CASE 64

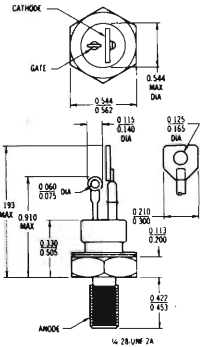

TO-52 CASE 27

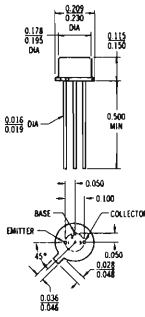

TO-59 CASE 160

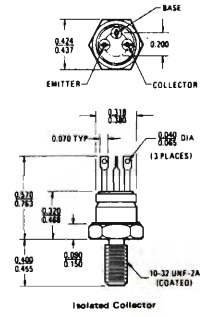

TO-60 CASE 36

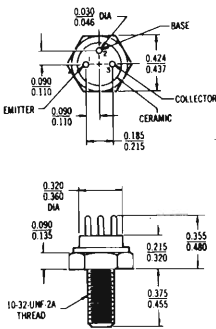

TO-61 CASE 79

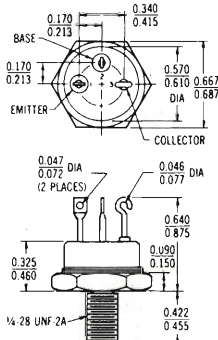

TO-63 CASE 188

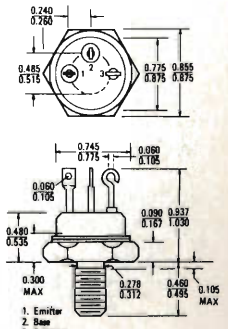

TO-66 CASE 80-2

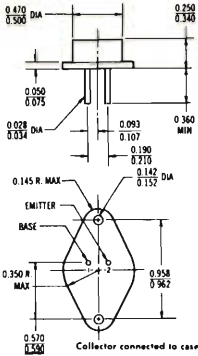

TO-68 CASE 7

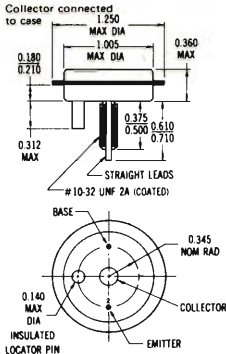

TO-72 CASE 20(9)

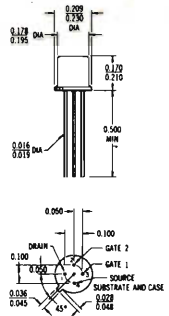

TO-72 CASE 20(10)

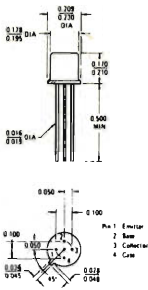

TO-76 CASE 196

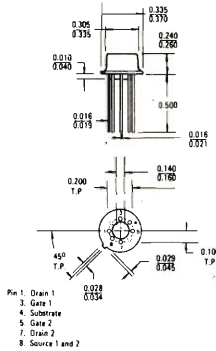

TO-86 CASE 83

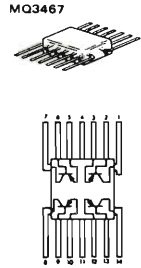

Lead 1 Identified by color dot or by elbow on lead.

TO-89 CASE 33

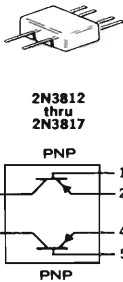

TO-92 CASE 29(2)

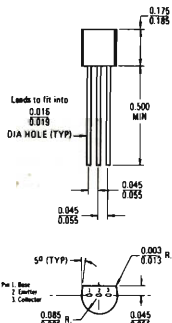

TO-102 CASE 24

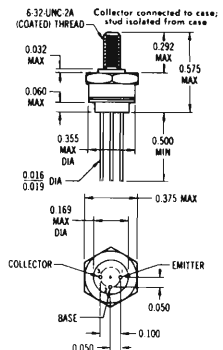

TO-107 CASE 23

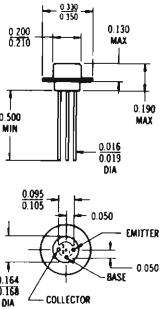

TO-114 CASE 177

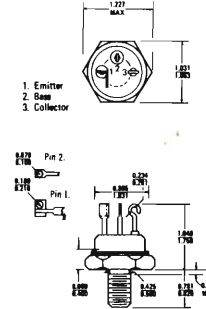

TO-220AB JEDEC

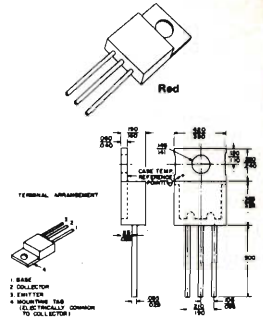

CASE 29-02

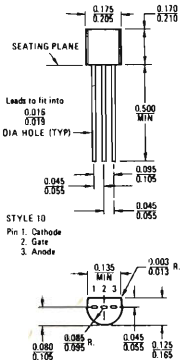

CASE 32C



CASE 32C

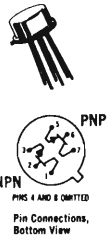

CASE 77-02

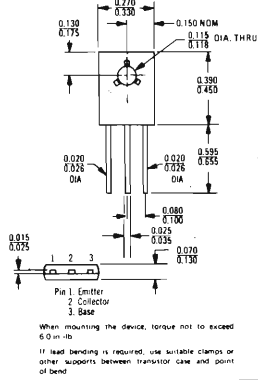

CASE 90

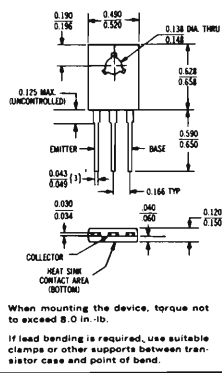

CASE 145A-02

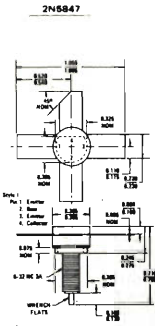

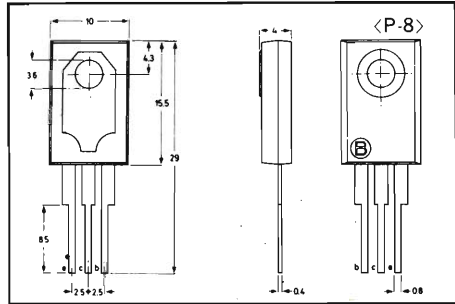
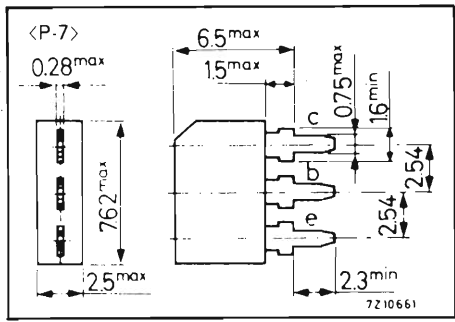
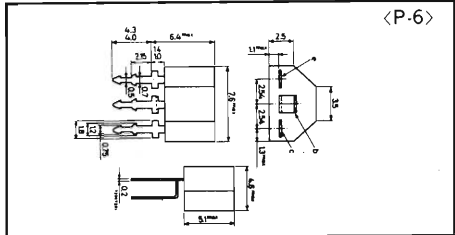
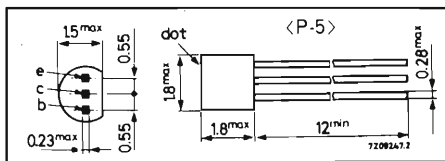
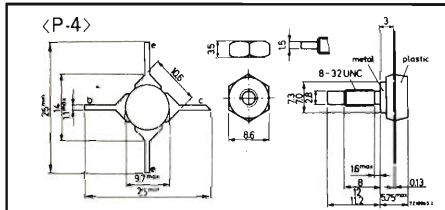
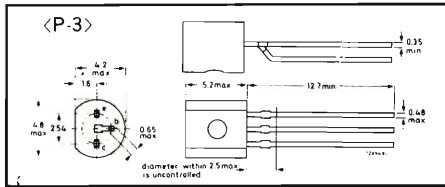
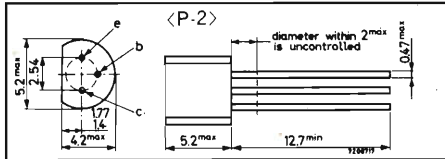
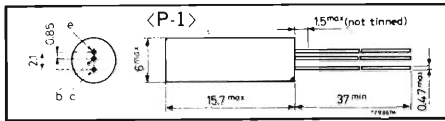
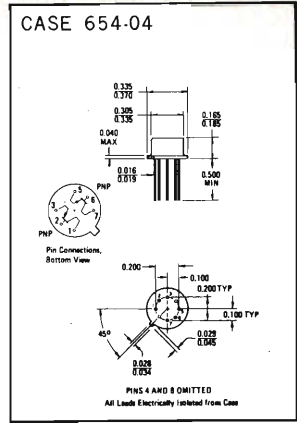
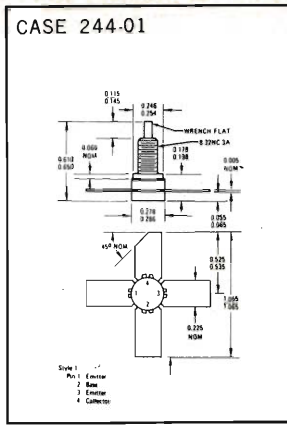
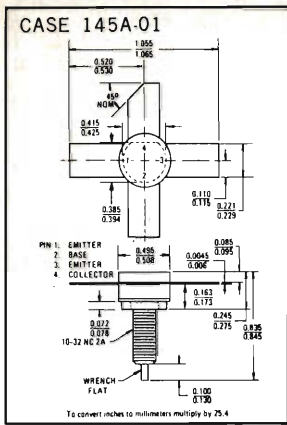

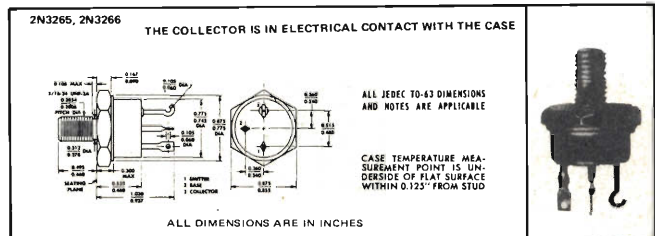
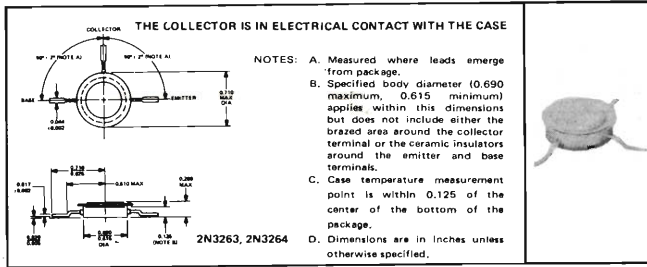
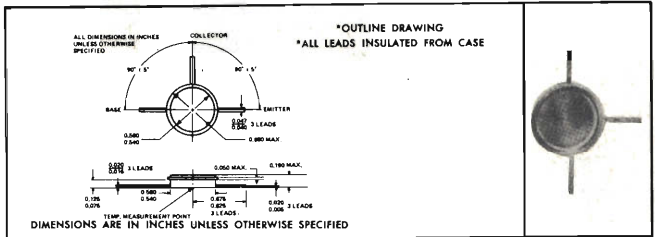
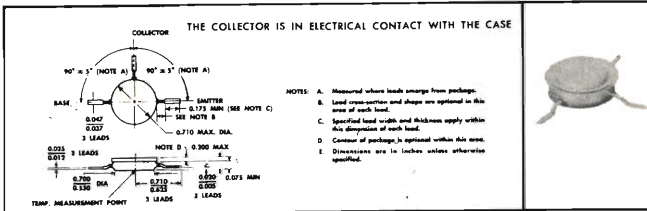
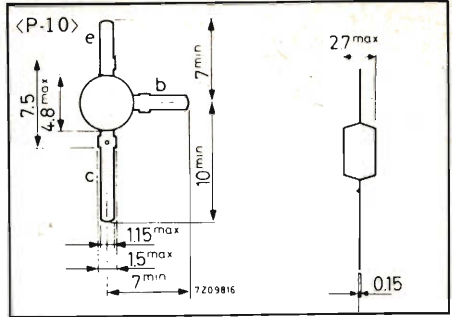
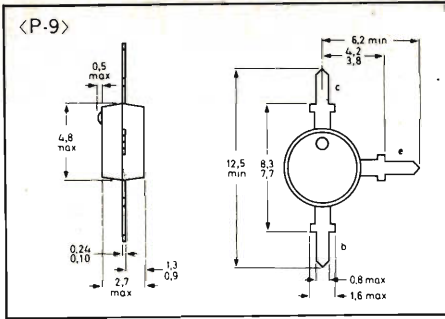

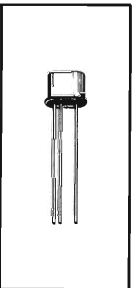
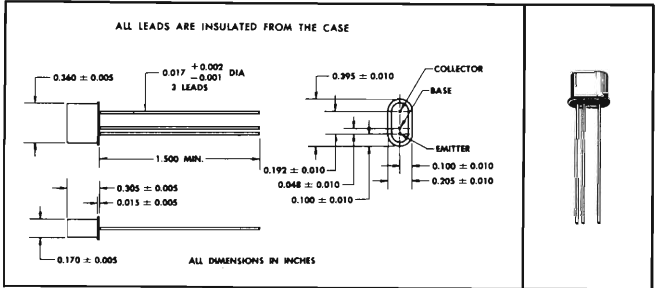
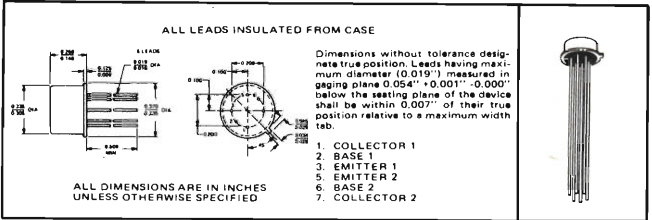
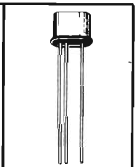
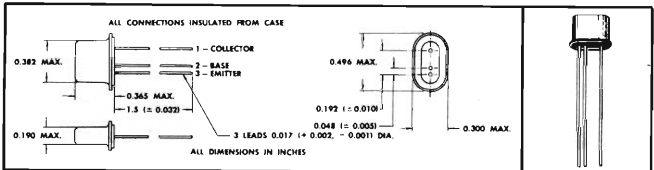
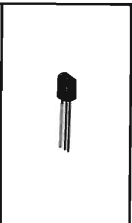
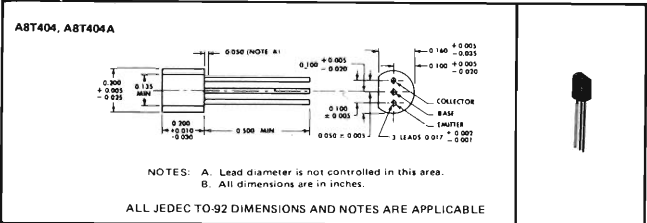
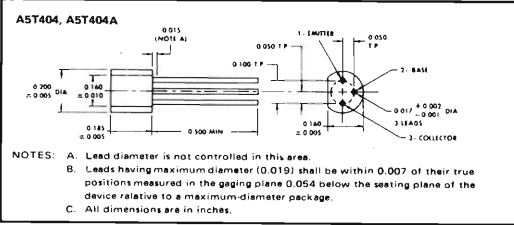

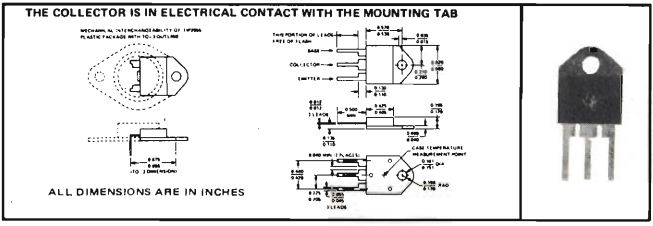
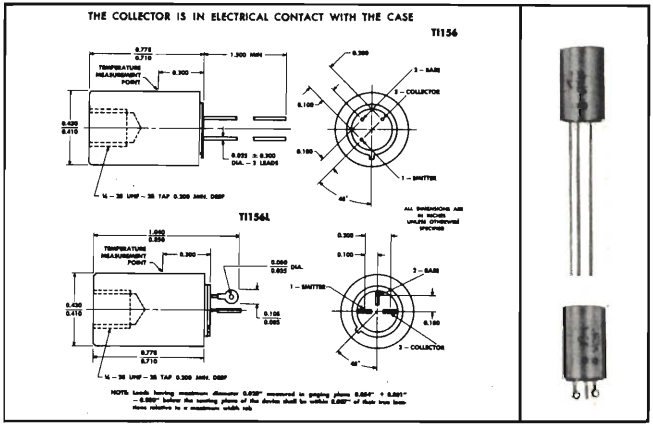
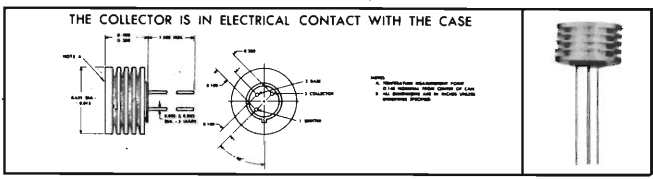
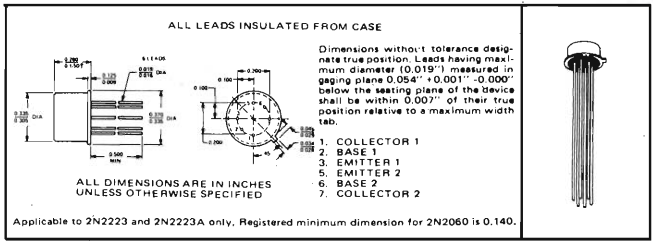
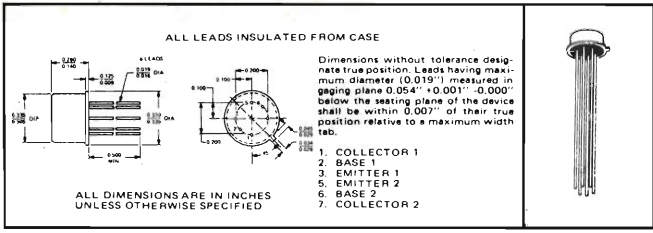

THE COLLECTOR IS IN ELECTRICAL CONTACT WITH THE MOUNTING TAB

MECHANICAL INTERCHANGEABILITY OF T1P120 PLASTIC PACKAGE WITH TO-18 OUTLINE

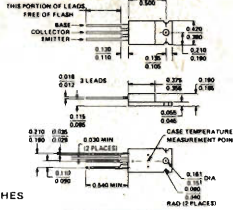

ALL DIMENSIONS ARE IN INCHES

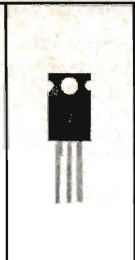

DIN 41871

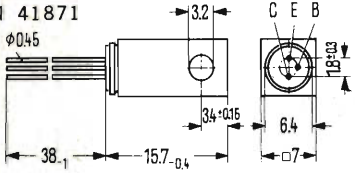

Weight approx. 4.8 g Dimensions in mm

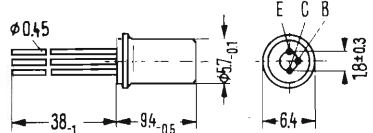

Weight approx. 1 g Dimensions in mm

DIN 41876

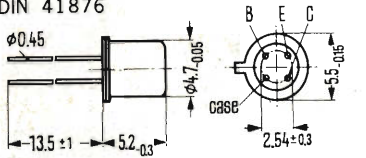

Weight approx. 0.4 g Dimensions in mm

DIN 41876

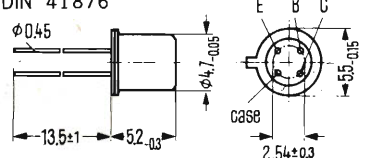

Weight approx. 0.35 g Dimensions in mm

U 32

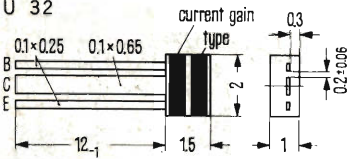

Weight approx. 20 mg Dimensions in mm

TOM 13

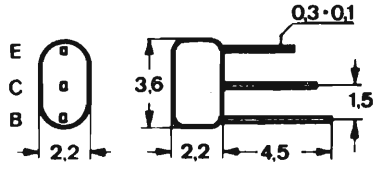

TOM 23

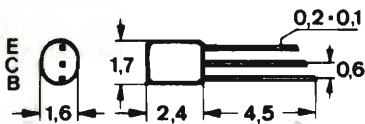

L. 8.000
(L. 7.547)

